

# TRI MO QBISS ONE

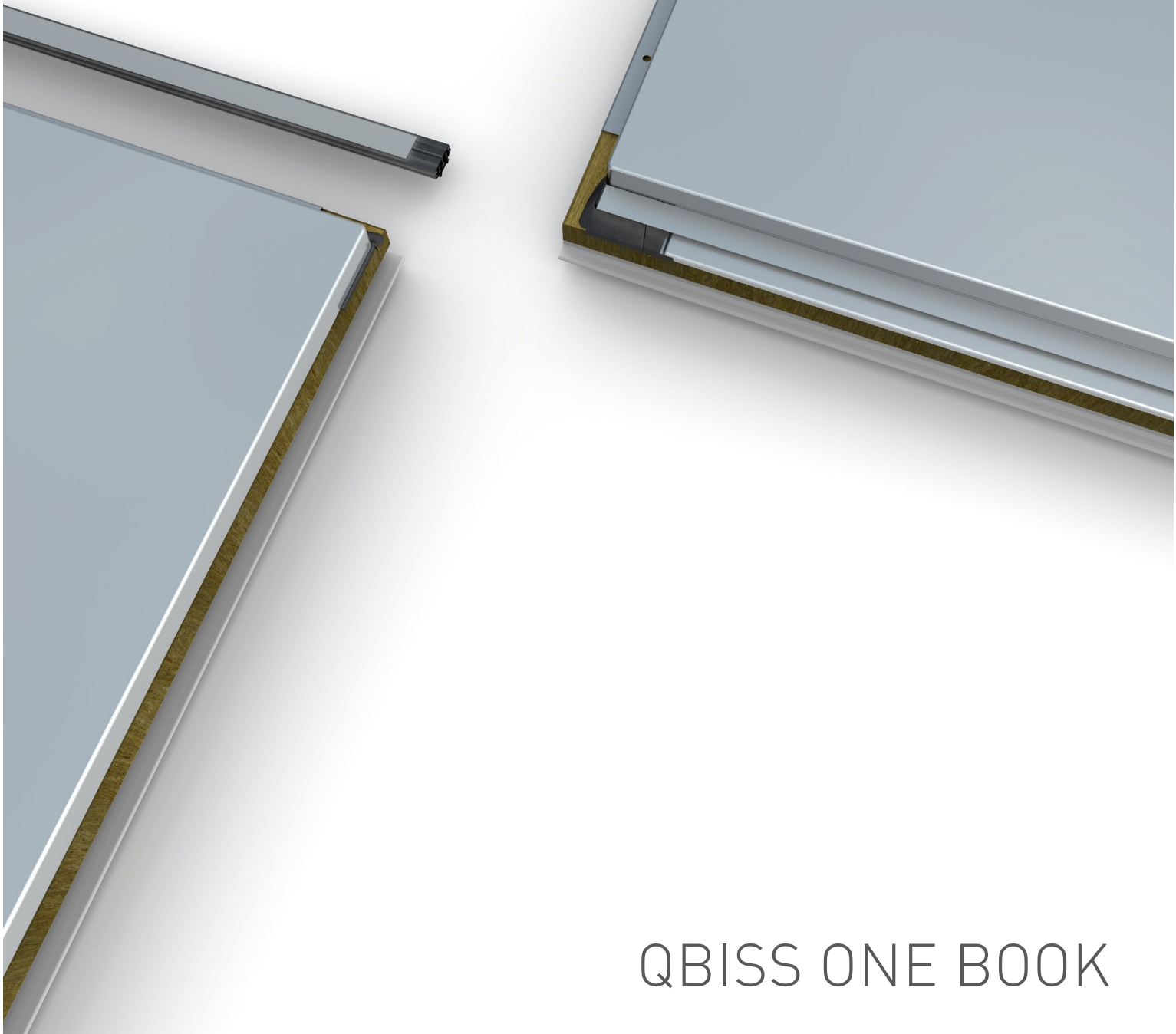

QBISS ONE BOOK

- document navigation tools,  
product tree  
navigating through a document tool
- Qbiss One book index

## **A DISCOVER** (PAGE A 1.0 - A 1.3)

- Qbiss One,  
prefabricated architectural wall  
world class engineering
- product portfolio

## **B ELEMENT DESCRIPTION** (PAGE B 1.0 - B 3.6)

- product advantages,  
advantages diagram
- element composition,  
composition  
steel sheet thickness and profile  
colours  
corrosion protection  
mineral wool
- measurements,  
measurements  
element tolerances  
thickness variations
- technical data,  
technical data for Qbiss One façade elements  
thermal transmittance  
fire safety

## **C ACCESSORIES** (PAGE C 1.0 - C 3.2)

- decorative elements,  
aluminium extrusions
- corner elements,  
uniqueness of Qbiss One elements
- 3D corner elements,  
outstanding feature of Qbiss One elements
- curved elements,  
curved Qbiss One elements
- trapezoidal elements,  
Qbiss One non-orthogonal elements
- Artme on Qbiss One,  
Artme
- internal wall,  
Internal wall solution

## **D SYSTEM DESCRIPTION** (PAGE D 1.0 - D 3.2)

- system composition,  
complete building envelope system  
joint variations  
installation direction  
types of load bearing structure
- levelling substructure,  
fast adjustable levelling system  
installation and control
- installation methods,  
various installation methods
- joint options,
- selection of fixing and methods  
selection of fixing

## **E INSTALLATION GUIDE** (PAGE E 1.0 - E 10.4)

- installation equipment,  
handling and lifting of the façade elements  
gripper for Qbiss One elements  
installation tools  
installation tool kit
- preparation for installation,  
removing the protective foil
- installation preferences,  
installation and control of the main structure or substructure
- Qbiss One site measurements  
production of Qbiss One elements after measurements
- architectural details,  
default setting  
horizontal details overview  
vertical details overview
- horizontal installation details,  
installation notes - step 1-5  
installation notes - brick installation
- vertical installation details,  
installation notes - step 1-5  
installation notes - brick installation
- system sealing,  
sealing details overview
- check-list

## **F SYSTEM RECOMMENDATIONS** (PAGE F 1.0 - F 2.4)

- design recommendations,  
structural design recommendations
- additional elements installation,  
install it like a pro
- replacement of damaged elements  
replacement of damaged elements
- specification,  
Specification of facade system
- handling, maintenance and waste,  
Packing, transport and storing,  
Maintenance of buildings,  
Treatment of waste

## **G SERVICE & SUPPORT** (PAGE G 1.0 - G 1.8)

- design,  
Qbiss One design service
- support & consulting,  
technical support service
- on-site support,  
clarity in operations for on-site efficiency
- parametric design,
- warranty,
- product management,  
research & development
- associated documents  
Qbiss One documents

## **H COMPANY PROFILE** (PAGE H 1.0 - H 1.2)

- company presentation,  
defining moments in the history of the Trimo group
- global presence



# DOCUMENT NAVIGATION TOOLS

## TRIMO PRODUCT TREE

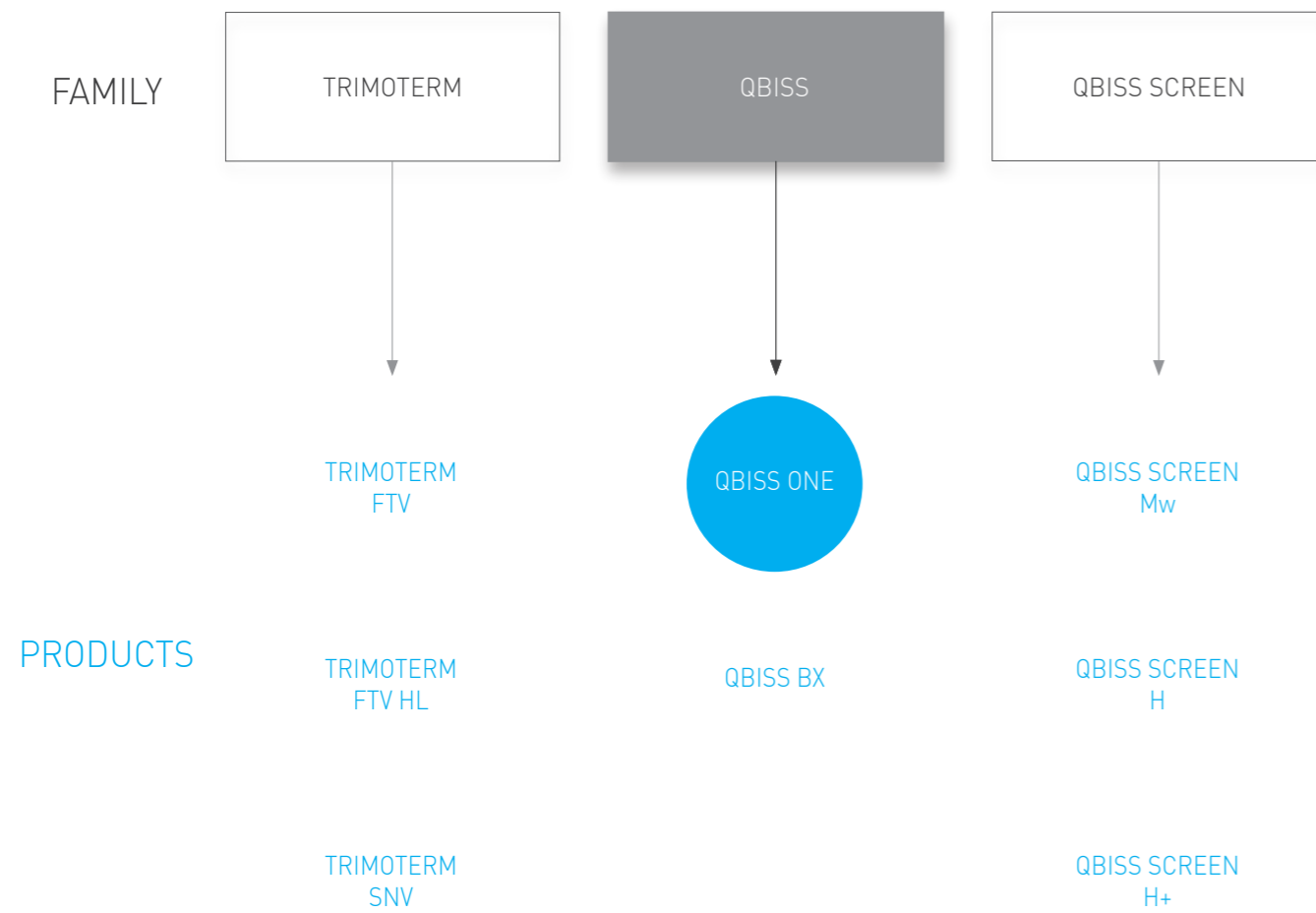

## NAVIGATING THROUGH A DOCUMENT

Navigation tools in this book allow you to navigate and browse easily through the document in several ways. You can find additional real case image explanations, useful notes, links to download external documents, such as detailed technical guides and design data, go to specific headings and pages using interactive table of content and much more. Find all navigation possibilities in the explanation boxes below.

This block contains nine numbered callouts (1-9) pointing to specific navigation features in the document:

- 1:** Document navigation options using interactive table of content.
- 2:** Useful notes and recommendations considering topics covered in a chapter.
- 3:** Smart page numbering enables individual document chapter print-outs.
- 4:** Additional real case image explanation.
- 5:** Useful home button links you back to the table of content.
- 6:** Useful links to learn more and play a video presentation.
- 7:** Useful internal navigation tool to link associated content within the document.
- 8:** Useful links to download associated external documents.
- 9:** Hyper-links for Trimo technical support team members to get to additional, topic related documents.



# QBISS ONE BOOK INDEX



## TERMS AND DEFINITIONS

For the purposes of Qbiss One technical book the following terms and definitions apply.

### A

Adjustable levelling substructure 64 72  
Airborne sound insulation 34  
Air permeability 34  
Allowed distances 189 190 191  
Aluminium extrusions 40  
Anchor bolt 155  
Anchor screws 71  
Architectural details 109 131 207  
Artme 60

### B

Building information modelling (BIM) 203  
Butt straps 155  
Butyl sealant 155

### C

Centering cross 99  
Circular saw 98  
Closed element corners 9 14 64  
Coating 34  
Concave 54  
Concept design 201  
Concrete structure 69  
Contact surface 69 71 72 153 155 167  
Convex 54  
Corner elements 64  
Corrosion 3 10 14 27 84 96 98  
Corrosion classification 27  
Corrosion resistance category 27

### D

Decorative Alu. extrusion 22 99 111 133 158 159 163 167 170 171 175  
Decorative Alu. extrusion HF40 22 99 159 163 170 171 175 178  
Deflection 188  
Design length 52 53 104 105 106  
Design length (R) 66  
Developed design 201  
Deviation of external steel sheet 31  
Dilatation slot 171 179  
Direction of installation 43  
Drill bits 98  
Drilling device 98  
Drip flashing 99 155 157 159 167

### E

Edge zones 187  
Element carriers 155  
Element distribution text 33  
Element edge shift 31  
Element end shift 31  
Element finishing 67  
Element thickness 31 33 44 46 48 51 52 53 80 84 85 104 105

Element type 67  
Embossed corner 9 10  
EPDM corner gasket 22 64 157 159 161 163 169  
EPDM cube gasket 99  
EPDM drip element 6 99 113 115 155 158 163 178  
EPDM transversal gasket 6 22 64 99 137 158 167 170 178 179 180  
External facing 34  
External steel skin 10

### F

Fire resistance class 11  
Fire resistance performance 35  
Fixing diameter 80  
Fixing length 81  
Fixing screw 64 75 178 188  
Flatness 31  
Flatness deviation 31  
Flush joint 65 160 172

### G

Genuine regulatory levels 35  
Geodetic scan 152 164  
Gridlines 74  
Ground plan 103

### H

Hammer 98 159 163 171 175 178  
High thread 84 85  
Horizontal installation 10 152

### I

Installation direction 66 67  
Installation kit package 89 99 160  
Installation method 67  
Instructions for installation 99  
Internal facing 34  
Internal steel skin 27  
Internal wall 3 61

### J

Jigsaws 98  
Joint options 78  
Joint profile 99 165 168  
Junction drip element 99 162 181  
Junction drip element - brick 162

### L

Latch 90  
Latches 94  
Load bearing fixing plate 22 64 99 157 159 169  
Longitudinal corner element 43 45 107  
Longitudinal curved element 54  
Longitudinal joint 34 174 176 180 181  
Lubricant 178

### M

Main structure 3 69 74 152 156 165  
Mantle 177  
Mastic seal 64  
Metal shears 98  
Metal sheet flashing 64  
Mineral wool 3 22 28 30 33 34 167 171 173 212  
Modular façade elements 11  
Module width 52 53 104 105 106

### N

Non-combustible reaction 28  
Non-hazardous waste 28

### P

Parapet wall 108 160 161 172 173 181  
PE-butyl tape 113 135 153 163 165 169 171 173 174 175  
Permissible deviation 102 155 167  
Permissible tolerances 69 71 152 153 164  
Pin 94 95 96  
Pitch 84 85  
Prefabricated architectural wall 8  
Pre-fabricated bores 156 168  
Product portfolio 10  
Protective foil 3 100 159 171  
Pyramidal system 68

### R

Rounded corner 9 10

### Q

Qbiss One book 99 207  
Qbiss One system 11 50 65

### R

Reaction to fire 34  
Reinforced concrete 75  
Robotized production train 43

### S

Sealing compound 163 175 179 180 181  
Sealing tape 64 75 133 153 154 155 157 159 161 163 166 167 169 173 175  
Segmentally curved element 56  
Self-drilling screw 84 85  
Self-tapping screw 153  
Side length 42 43 46 47 48 49 107 156 168  
Soffit 50  
Solid colours 10  
Special metallic 10  
Spread of flame 35  
Square gasket 180  
Staining resistance 27  
Stainless steel 10 25  
Steel column face 153  
Steel sheet 3 27 31 84 92 155 156 173

Steel skeletal structures 75  
Steel structures 69 71 74  
Structural analysis 153 201  
Structure members 153 165  
Suction load 187  
Support frames 71 153 165  
Swarfs 84 157 169  
System composition 64

### T

Technical design 201  
Technical support team 53 59 197  
Thermal insulation 34  
Thermal transmittance 34 35  
Thickness of substructure 84 85  
Three-dimensional corner elements 50  
Tolerance of external steel sheet 31  
Torque limiter 84  
Transversal corner element 44  
Transversal curved element 54  
Transversal joint 34 159 170 171 176 178 180 181  
Transversal U-corner element 44  
Trapezoidal elements 3 14 18  
Trimo product tree 4

### U

UV resistance category 27

### V

Vapour barrier 160 172  
Vertical installation 10 164  
Vertical load fixation 154 166  
Vertical load fixing screw 64 99

### W

Washer 81 84 85  
Water permeability 11 34  
Water tightness 153 167  
Water-tight seal 30  
Water vapour permeability 34  
Wind pressure 189 190 191  
Wind suction 187 189 190 191  
Wind zone 186  
Wooden bar with protective felt 99  
Wrenches 98

# QBISS ONE

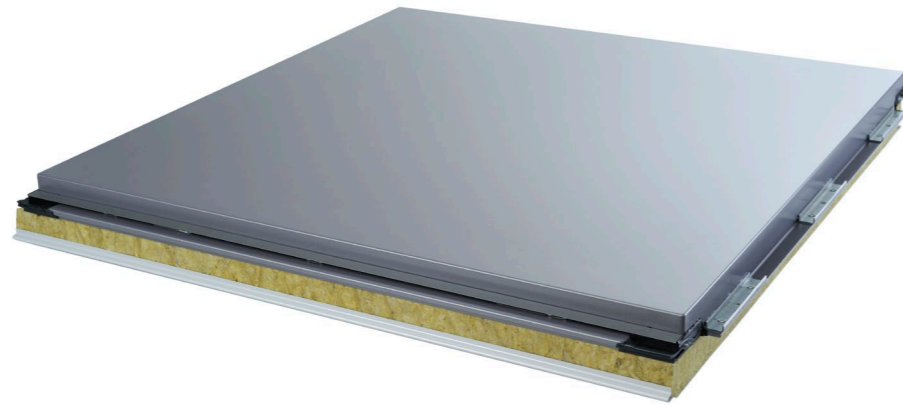

## PREFABRICATED ARCHITECTURAL WALL

Qbiss One is a design and technological breakthrough. An architectural metal wall offers a true alternative to conventional build-up system. Qbiss One delivers the greatest freedom of expression and offers designs of almost limitless possibilities.

Qbiss One is a world-class engineered, prefabricated, A1 mineral wool insulated, metal façade system that offers a through wall solution within a single piece of construction element. Façade elements with rounded corners, unmatched flatness and advanced technical characteristics place Qbiss One among the best façade systems in the world.

It brings system approach to the building envelope by uniting all the desired functional advantages of high-quality wall systems with the best aesthetics. The combination of aesthetics, design and function are all united in one system.

## WORLD CLASS ENGINEERING

Qbiss One is distinguished by the unique rounded corner of the element. The design is the result of world-class engineering and the highest automated technology and patented manufacturing systems.

Unique rounded corner provides a superior aesthetic appearance whilst also preventing any potential threat of corrosion. All other available products on the market use a "cut and fold" design that needs to be sealed manually and then touched-up with paint.

Qbiss One system has successfully undergone rigorous testing in accordance with the latest CWCT (Centre for Window and Cladding Technology) standard. The tests were carried out by Wintech Engineering Ltd, one of the UK most renowned, independent, UKAS accredited, testing laboratories.

The system also passed the tough FM 4881 hurricane test.

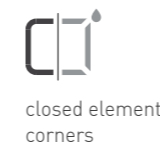

Qbiss One is distinguished by the unique rounded corner of the element which results in superior aesthetics without any cuts, folds or welds.

# A. DISCOVER PRODUCT PORTFOLIO

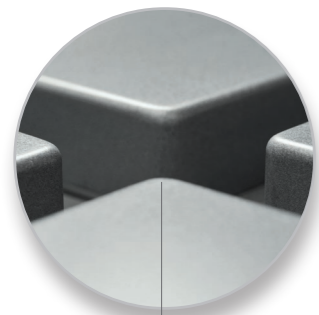

QBISS ONE ELEMENT  
ROUNDED CORNER

## JOINT OPTION FOR HORIZONTAL INSTALLATION



QBISS ONE B-B QBISS ONE B-BF QBISS ONE BF-B QBISS ONE BF-BF QBISS ONE F-B QBISS ONE F-BF

## JOINT OPTION FOR VERTICAL INSTALLATION



QBISS ONE B-B QBISS ONE B-BF QBISS ONE BF-B QBISS ONE BF-BF

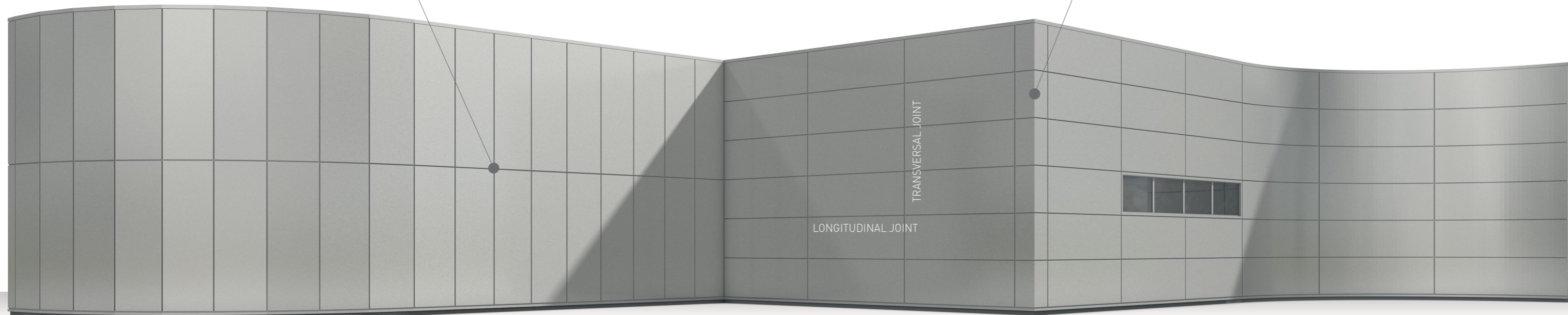

# A. DISCOVER

## TYPICAL INSTALLATION DETAILS

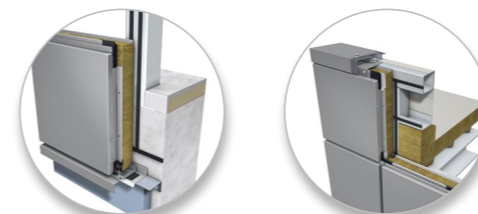

BASE DETAIL TOP PARAPET DETAIL

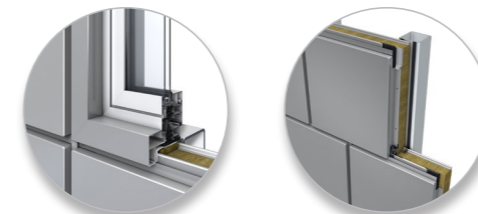

WINDOW FIXED GLASS BRICK

## CORNER ELEMENTS



PREFORMED TRANSVERSAL CORNER ELEMENT SHARP-EDGED CORNER FLASHING

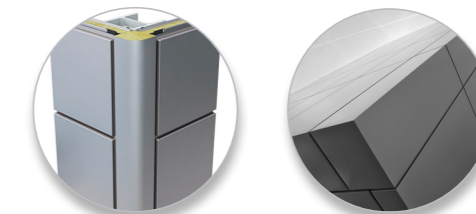

ROUNDED CORNER FLASHING PREFORMED 3D CORNER

## COLOUR RANGE

External steel skin is available for different corrosion environments of up to C5 (according to classification in EN12944) and is available in a variety of colours. Colour range presented shows only a fraction of most usable colours within the variety of colours available. Other colours are available upon request.

## DISCLAIMER

Colours may deviate slightly due to different monitors and prints compared to original colours. Trimo can send you a metal swatch upon request.

Colour range does not in any case define delivery terms or any other terms of specific skin colour.

## SOLID COLOURS



## SPECIAL METALLIC

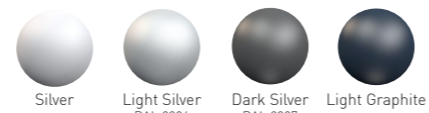

## ELEMENTS\*



## STAINLESS STEEL\*\*



Qbiss One façade element consists of two galvanized and pre-finished steel sheets bonded to a non-combustible A1 mineral wool core. All layers together make a solid element.

Qbiss One system consists of:

- Modular façade elements
- Fixing and sealing material
- Architectural performance details
- Corner elements
- Adjustable substructure (optional)
- Windows (optional)

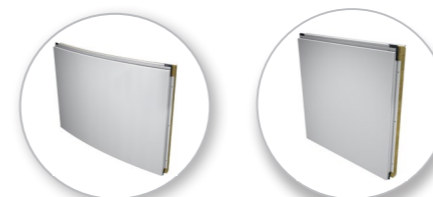

CURVED FAÇADE ELEMENT FLAT FAÇADE ELEMENT

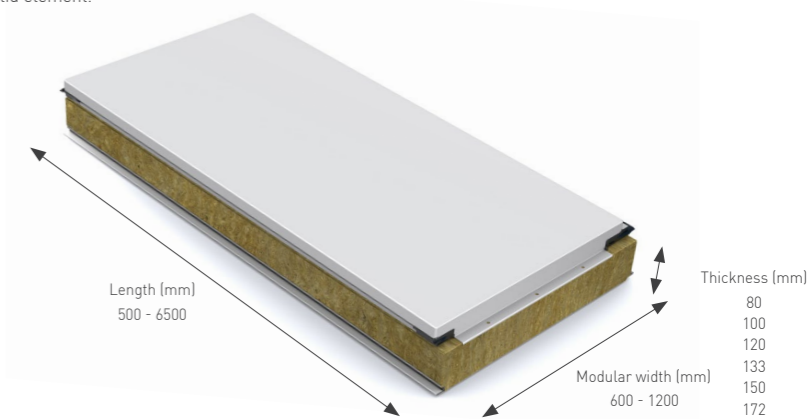

FIRE RESISTANCE CLASS UP TO EI 120  
U VALUE AS LOW AS 0.15 W/m<sup>2</sup>K  
WATER PERMEABILITY UP TO 1200 Pa

\*Colorcoat Prisma and Seren are trademarks of Tata Steel UK Limited  
\*\*Stainless steel is a bespoke solution and shall be discussed with the Trimo technical department on an individual project basis from an application and availability perspective.



B. ELEMENT DESCRIPTION

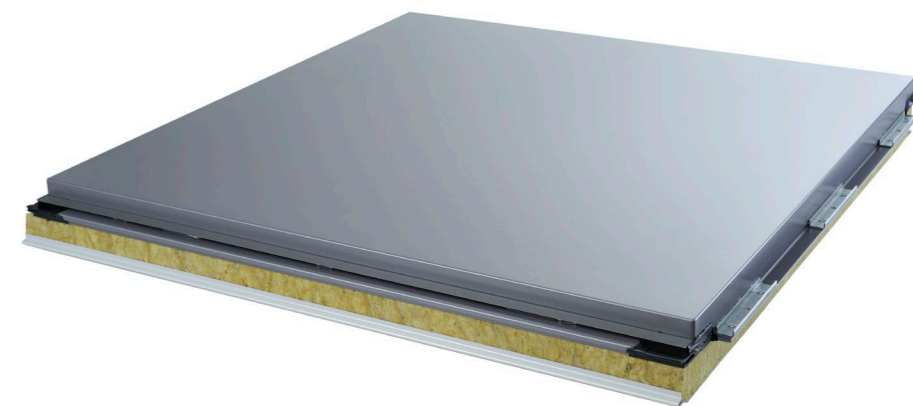

# PRODUCT ADVANTAGES

ADVANTAGES DIAGRAM



closed element corners

ADVANTAGES

FEATURES

BENEFITS

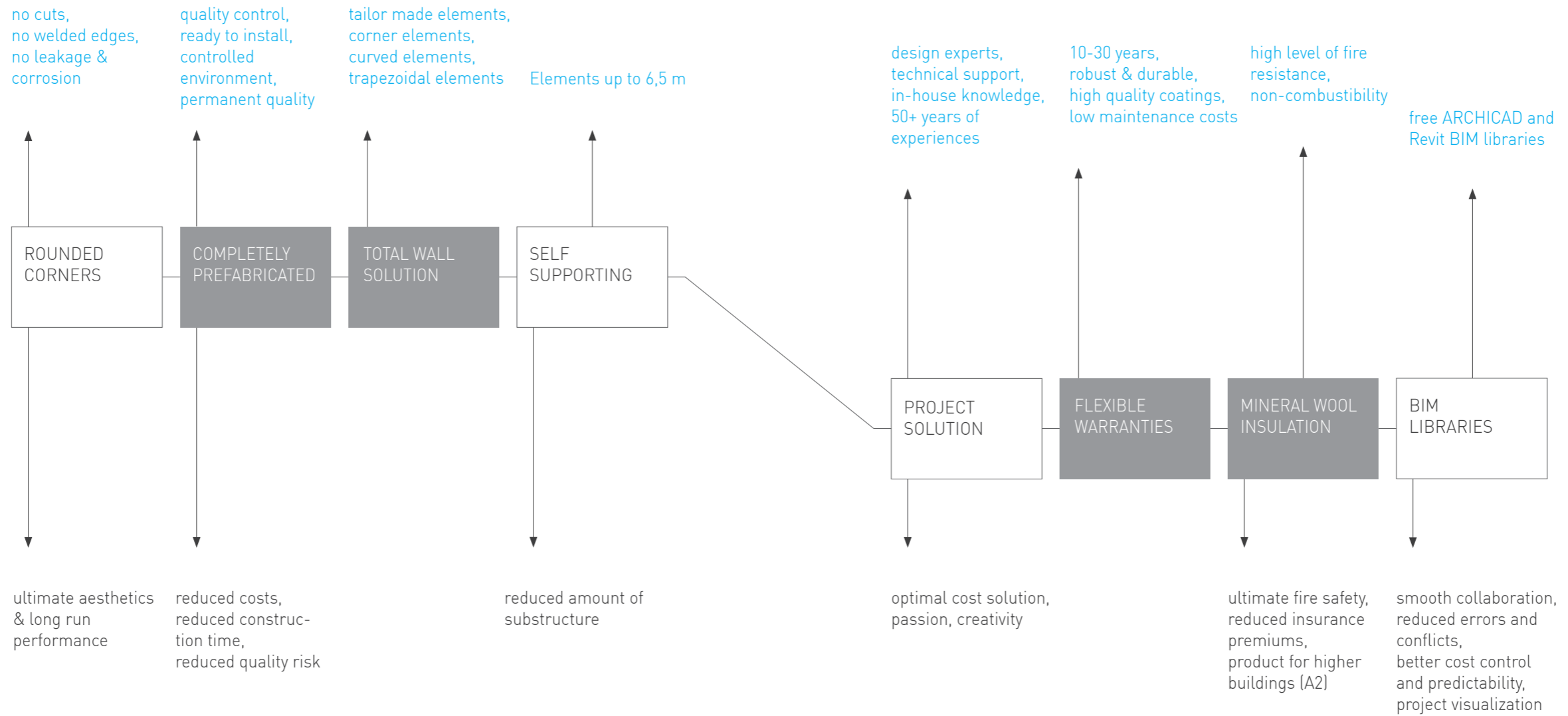

ADVANTAGES

FEATURES

BENEFITS





**FIRE-RESISTANT SYSTEM WITH THE MINERAL WOOL CORE**

The system is fire-resistant for up to two hours with the mineral wool core of only 150 mm.



**AIRTIGHT AND WATERTIGHT WALL SOLUTION**

Qbiss One is a fully wind, air and watertight single wall solution. Tests have been corroborated with the latest CWCT standard performed by UKAS accredited testing laboratories. System water permeability is classified as Class A (1200 Pa).



**ROUNDED ELEMENT CORNERS**

Qbiss One is aesthetically pleasing, with outstanding flat surfaces and crisp details: in particular, the rounded corners are made without any cuts, folds or visible fixings.



**TOTAL WALL SOLUTION**

Qbiss One is fully prefabricated, offering quick, precise and efficient installation (40% quicker compared to a rainscreen installation).

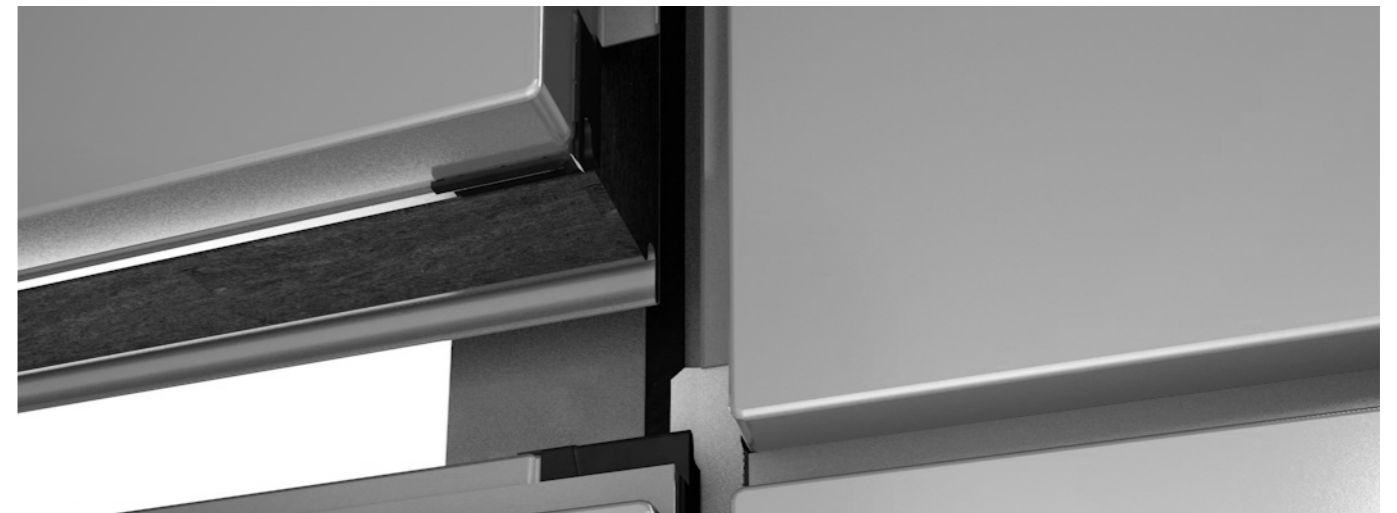

**COMPLETELY PREFABRICATED ARCHITECTURAL WALL**

Qbiss One System brings all the necessary components of a total wall (from inside out) solutions including prefabricated corner, curved and trapezoidal elements.



**SELF-SUPPORTING WALL ELEMENT**

Elements are self-supporting, bearing its own loads to eliminate transferring loads to the next element and beyond.



**FLEXIBLE WARRANTIES**

Trimo provides a system warranty based on location of the building site and environment classification.



**PROJECT SOLUTION**

In-house design department provides the most optimal solution to your project requirements. Trimo BIM libraries ensure efficient information management and enable fast building envelope design. Non-standard details - No problem.



## [🏠](#) B. ELEMENT DESCRIPTION

### 99% RECYCLABLE

Qbiss One façade element consists of two galvanized and pre-finished steel sheets bonded to the non-combustible A1 mineral wool core. Together with EPDM gaskets and adhesive, elements are made of 97-99% recyclable material. It has a low CO<sub>2</sub> footprint of just 60 kg/m<sup>2</sup> during the product stage (EPD, Qbiss One, 12 December 2019).

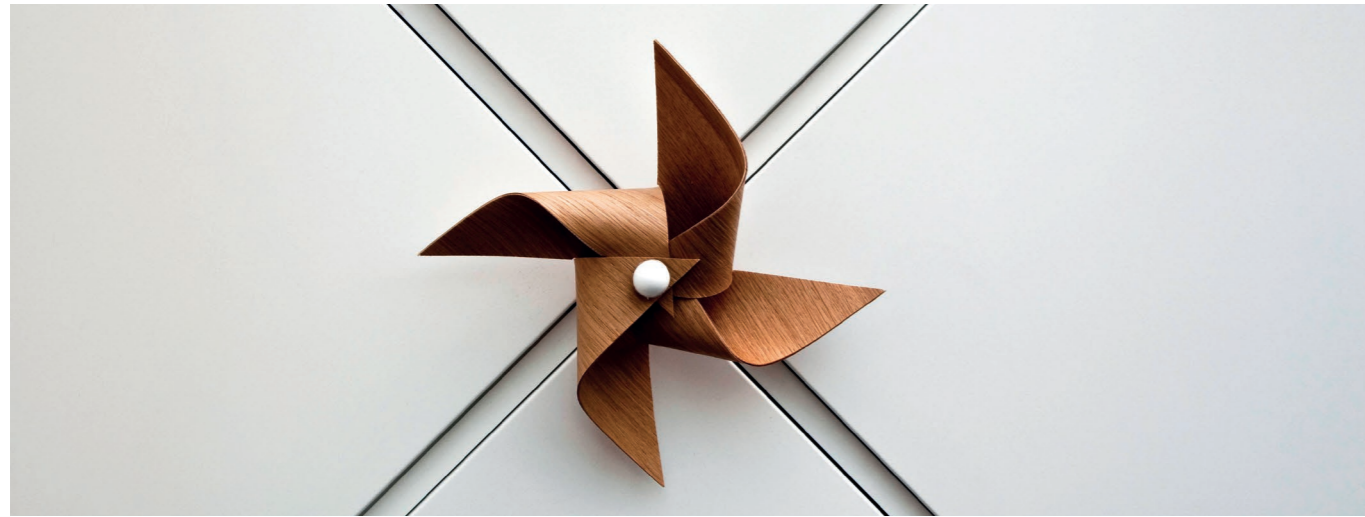

HEADQUARTERS OF BOLSIUS INTERNATIONAL  
NETHERLANDS

HORIZONTAL QBISS ONE

2018  
PEPERS ARCHITECTEN



# ELEMENT COMPOSITION

## COMPOSITION

The basic element of Qbiss One is a modular wall element, made by an automated and robotic production line. Pre-finished steel sheets are bonded to a non-combustible mineral wool. All three layers form a solid prefabricated façade element.

**Qbiss One façade element** consists of two galvanized and pre-finished steel sheets bonded to non-combustible A1 mineral wool core. All layers together make a solid element of thickness ranging from 80 mm to 250 mm. Qbiss One is available in either flat or curved options.

Preinstalled gaskets prevent water to enter the system, drip element serves as a secondary protection and drains water out of the system, decorative Alu. extrusion HF40 defines colour of the joint and together with EPDM transversal gasket covers fixing elements and protects water ingress.

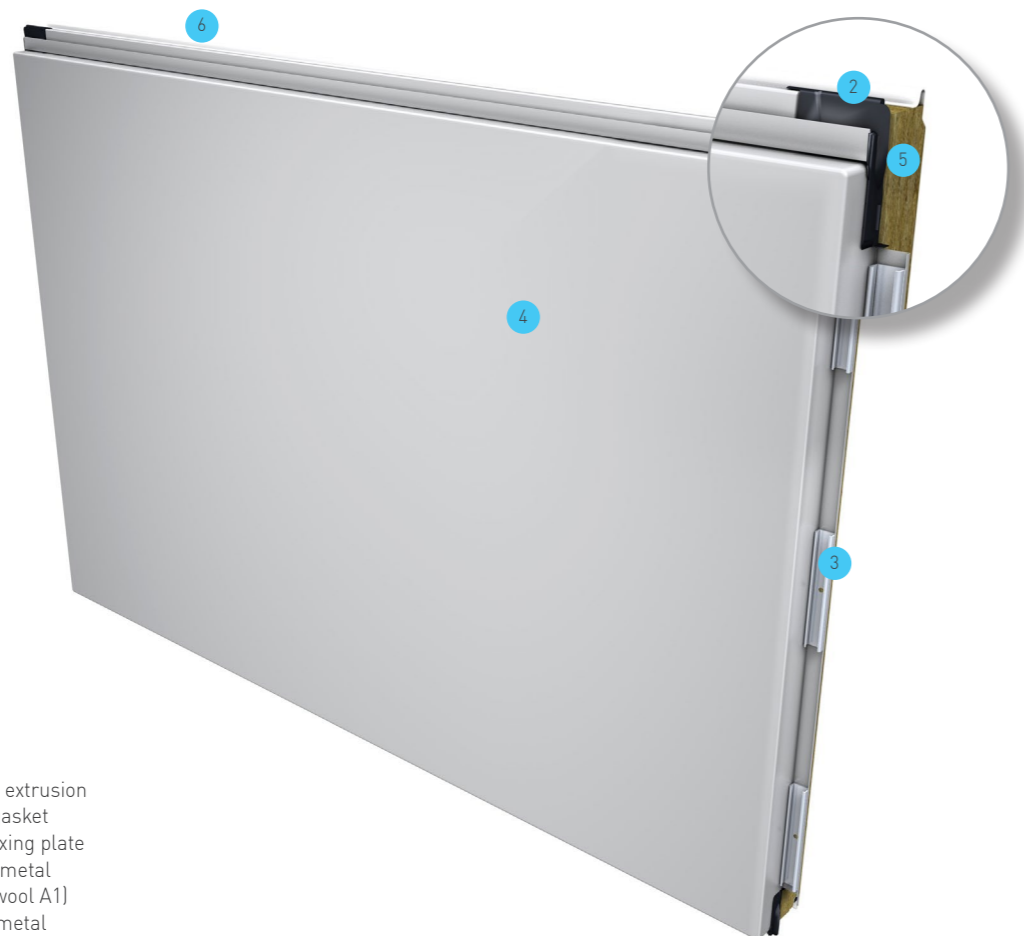

- 1 Decorative Alu. extrusion
- 2 EPDM corner gasket
- 3 Load bearing fixing plate
- 4 External sheet metal
- 5 Core (mineral wool A1)
- 6 Internal sheet metal

## STEEL SHEET THICKNESS AND PROFILES

Experiences from the past lead us to perfection. Having a clean design in our mind, we achieved a perfect flatness of the external side by using 0,7 mm thick steel sheet. While using only smooth profile on the external side of Qbiss One, there are other multiple profile options to choose from for internal side of Qbiss One element.



V - profile (standard profile)

### PROFILES

External skin thickness: 0,7 mm

Smooth profile (G)



Internal skin thicknesses: 0,5 mm; 0,55 mm; 0,6 mm; 0,7 mm

V - profile (V) / standard

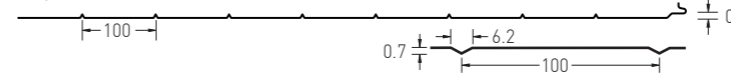

V - profile (V2) / optional

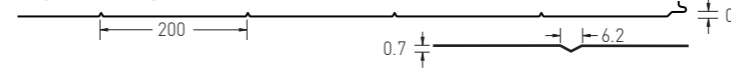

Smooth profile (G) / optional



S - profile / optional



M - micro-lined profile (M) / optional



M - micro-lined profile (M3) / optional



COLOURS

With exceptional technical characteristics and perfect visual expression, Trimo façade system easily adapts to your vision of space. To meet our customer's needs, we prepared a range of colour coatings, suitable for external and internal side of Qbiss One elements.

Pick your colours from:

 [Qbiss One colour chart](#)

**SPECIAL METALLIC**

	TRIMO COLOUR	NEAREST RAL OR OTHER REFERENCE COLOUR
	SILVER	RAL 9006
	LIGHT SILVER	N/A
	DARK SILVER	RAL 9007
	LIGHT GRAPHITE	N/A





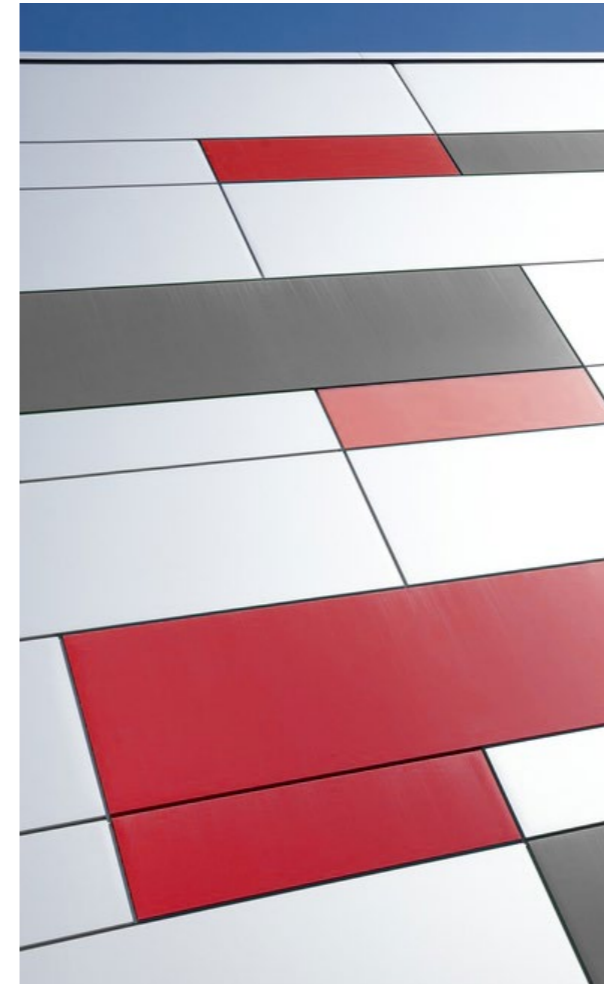

**SOLID COLOURS**



	TRIMO COLOUR	NEAREST RAL OR OTHER REFERENCE COLOUR
	WHITE	RAL 9010
	GREY WHITE	RAL 9002
	LIGHT GRAY	RAL 7035
	CREAM	RAL 1015
	BASALT GREY	RAL 7012
	SAPPHIRE BLUE	RAL 5003
	TRAFFIC RED	RAL 3020
	ANTHRACITE	RAL 7016
	BLACK	RAL 9005

**STAINLESS STEEL**

On a project-by-project individual basis Trimo can provide a bespoke solution of Qbiss façades from stainless steel in order to preserve the long-term value of the building and provide a unique architectural solution and long-lasting appearance. Availability and application will be discussed with Trimo technical department.

	MATERIAL		MATERIAL
	QUADRO LUCIDO		DOTS LUCIDO
	2WL LUCIDO		5WL LUCIDO
	PELLE LUCIDO		

! Colours may slightly deviate due to different monitors and prints compared to original colours. On request Trimo will send you a metal swatch.

On a project-by-project individual basis Trimo can provide a bespoke solution of Qbiss façades from imitating Corten, Copper, Wood, Stone etc. in order to preserve the long-term value of the building and provide a unique architectural solution & appearance. Availability and application will be discussed with Trimo technical department.

**COLORCOAT PRISMA® ELEMENTS\***

External steel sheet is a hot dip galvanized thin steel sheet (according to EN10346) and pre-painted by »coil coat« technology. External sheets are available for different corrosion environments as defined for certain project. Organic paint protections are available for environment corrosion classes up to C5, (according to classification in EN12944). Trimo anti-corrosion guarantees for wall application of special metallic and solid colours:

- C5 = 12 years**
- C4 = 15 years**
- C3 = 25 years**

Special guarantees terms and conditions apply when using Tata Steel Colorcoat Prisma® Element colours with the Confidex® Guarantee by Tata Steel being available.

TRIMO COLOUR	NEAREST RAL OR OTHER REFERENCE COLOUR
	SIRIUS SPARKLE Colorcoat Prisma® COLOUR
	ORION SPARKLE Colorcoat Prisma® COLOUR
	ZEUS SPARKLE Colorcoat Prisma® COLOUR
	SEREN WHITE Colorcoat Prisma® COLOUR
	SEREN SILVER Colorcoat Prisma® COLOUR
	SEREN TITAN Colorcoat Prisma® COLOUR
	SEREN GOLD Colorcoat Prisma® COLOUR
	SEREN COPPER Colorcoat Prisma® COLOUR
	SEREN BLACK Colorcoat Prisma® COLOUR
	ANTHRACITE SOLET Colorcoat Prisma® COLOUR
	SEREN MIDAS Colorcoat Prisma® COLOUR

\* Colorcoat Prisma and Seren are trademarks of Tata Steel UK Limited.

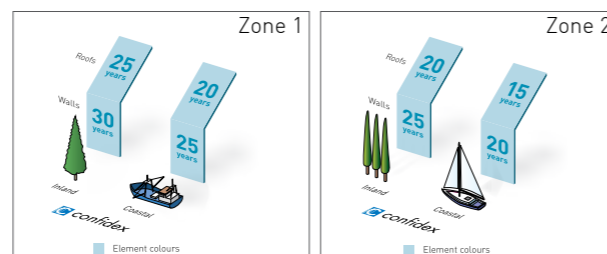

- ! Figures under the Coastal heading are for buildings within 1 km of any coast.
- Full terms and conditions of the Confidex® Guarantee are available on the on-line application form, available at [www.colorcoat-online.com/registration](http://www.colorcoat-online.com/registration)
- Confidex® must be registered within 3 months of the building completion date for the guarantee to be valid.
- The Confidex® Guarantee periods on the diagram above are applicable to Zone 1 and Zone 2. For more information on other zones visit: [www.colorcoat-online.com/confidexmap](http://www.colorcoat-online.com/confidexmap)

**CORROSION ATMOSPHERE STEEL SHEET PROTECTION**

Type of corrosion protection	External steel skin				Internal steel skin							
	PVDF	PVDF+	PUR/PA	Stainless steel	SP	PVDF	PVDF+	PUR/PA	PVC(P)	PVC(F)	Stainless steel	
Total organic thickness (µm) [EN 13523-1]	25	35-57	50		25	25	35-57	50-65	175-200	120-150		
Corrosion resistance category	External EN [10169]	RC3	RC4	RC5	-	-	-	-	-	-		
	Internal EN [10169]	-	-	-	CPI3	CPI3	CPI5	CPI5	CPI5	CPI3		
Types of outdoor atmosphere corrosivity category	Rural - normal	C2	••••	••••	••••	••••	••••	••••	••••	••••	Internal use only 304, 304L, 316, 316L	
	Urban and light industrial (low SO <sub>2</sub> )	C3	••••	••••	••••	••	••••	••••	•	•		
	Industrial (moderate SO <sub>2</sub> )	C4		•••	•••			•••	••••	•		Internal use only
		0 < 5 km from sea	C5-M		•	•		•	•	•		
	> 5 km from the sea	C5-M		•	•••		•	•••	•	•		
Severe industrial	C5-I		•	•		•	•	•	•			
Temperature resistance (°C)	110	110	110		80	110	110	110	60	60		
UV resistance category [EN 13523-10]	Ruv4	Ruv4	Ruv4		Ruv3	Ruv4	Ruv4	Ruv4	Ruv4	-		
Flexibility	•••	••••	••••		••	•••	••••	••••	••••	••••		
Staining resistance	••••	••••	••••		•••	••••	••••	••••	••	••••		

- Suitable without limitations
- Very suitable
- Suitable
- Contact Trimo for consultancy
- Unsuitable



## CORROSION PROTECTION

We don't accept anything less than the best for our products. The most harmful part of the element is face side. It is exposed to environment impact, therefore it must be well protected in order to last long. We discuss corrosion with confidence. Only pre-painted steel sheet with the best protection on the market is being used to produce the façade elements. External side (the one exposed to the environment) of Qbiss One element is protected with PUR or PVDF protection. For the most optimal results we can adjust protection of the element's internal side based on the building purpose.

## MINERAL WOOL

Core constituent of Qbiss One element is mineral wool. It is an insulation material made of melted stone of volcanic origin and then fiberized. It is considered as recyclable component. Water repellent role prevents water to enter the elements, fire-resistance function prevents fire to spread, excellent thermal insulation ensures low consumption of energy for heating/cooling of the building.

There are 3 different types and 10 different thicknesses of mineral wool to be used in Qbiss One elements.

**Perform C:** is versatile, robust and compact mineral wool where building safety and longevity are paramount.

**Power T:** guarantees extremely high thermal insulation, stable indoor climate and energy savings through reduced heat loss and lower running costs even in most demanding climate environments.

**Power S:** ensures higher structural spanning capabilities, while also achieving superior strength that is capable of withstanding high wind loads. Qbiss One elements with Power S mineral wool enable up to 100% faster installation and durable performance.



### MINERAL WOOL KEY ADVANTAGES

- Class A1 non-combustible reaction to fire classification.
- High density 90-120 kg/m<sup>3</sup> for superior structural strength.
- Environmentally friendly, landfill disposal as non-hazardous waste.
- Recycling costs up to 5 times less vs PIR/PUR insulation
- Does not absorb water.
- Retains thermal and structural performance throughout its lifetime.
- Does not provide the environmental conditions for bacteria growth and rodent animals, thus is also suitable for construction in the food & pharmaceutical industries, clean rooms, etc.



CORUÑA THE STYLE OUTLETS  
SPAIN

HORIZONTAL QBISS ONE

2011  
ROSA LÓPEZ

## B. ELEMENT DESCRIPTION MEASUREMENTS

### MEASUREMENTS

The basic element of Qbiss One is a modular wall element, which is made by an automated and robotic production line. Pre-finished steel sheets are bonded to the core, which is made out of non-combustible mineral wool. All three layers form a solid prefabricated façade element.

Discover Qbiss One B-B and Qbiss One F-B horizontally laid element.

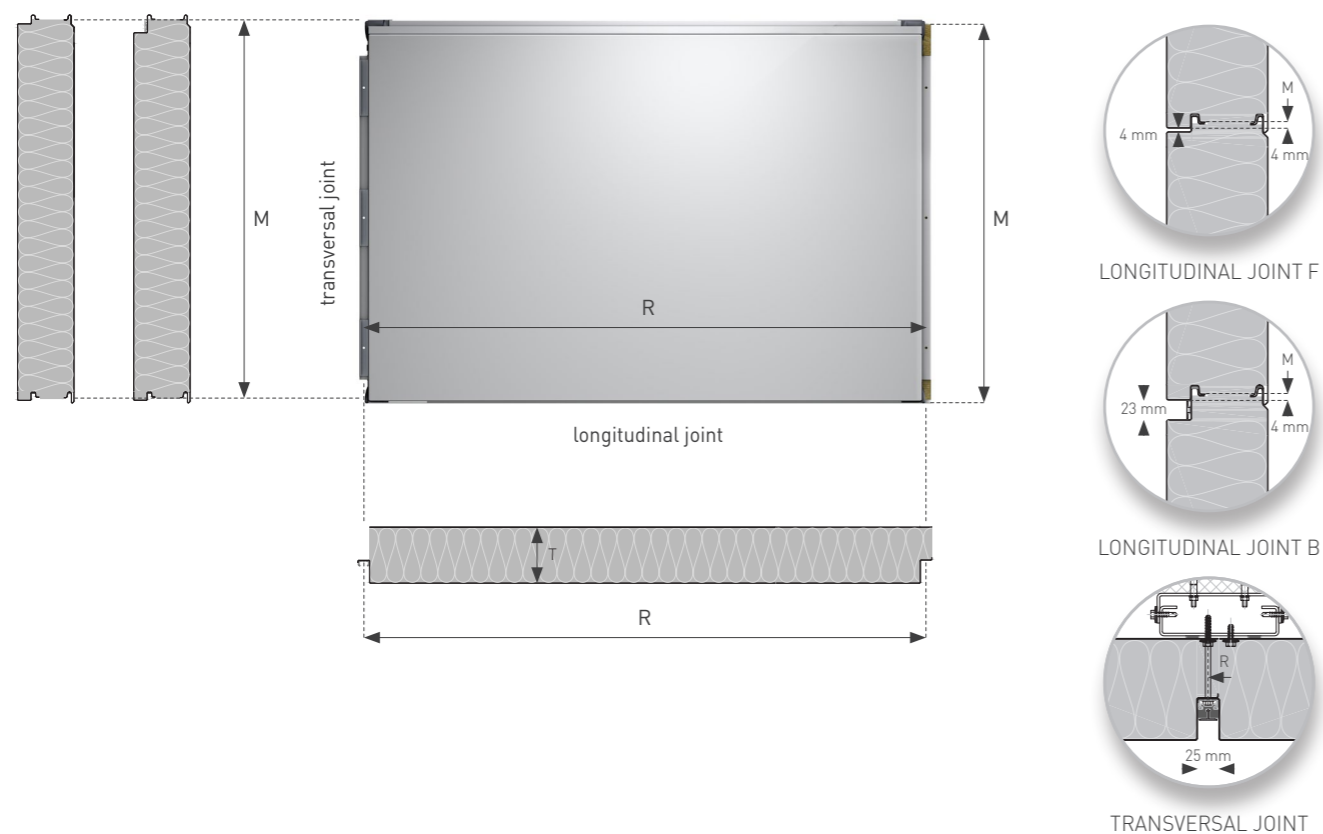

The element is defined by the raster length - R and the module width of the façade element - M. In the façade installation, the elements form the longitudinal and transversal joint

**The longitudinal joint** is the joint formed by the tongue and groove of the façade element. The joint dimensions are **23x24 mm** (width x depth). All values are stated in millimetres.

**The transversal joint** is formed by the edges of the façade element. Façade elements are fixed to the structure using screws. The sealing of the transversal joint is accomplished using an inserted sealing and decorative profile which ensures an air- and water-tight seal, and consequently air and water tight façade system. The joint dimensions are **25x24 mm** (width x depth). All values are stated in millimetres.

## B. ELEMENT DESCRIPTION

### ELEMENT TOLERANCES

Tolerance is the upper and lower acceptable limit for measurements. It can be applied to every measurable aspect of manufacturing element. Tolerances for rectangular Qbiss One elements are in accordance with EN14509 standard in conjunction with Qbiss One system specification.

Check Qbiss One element tolerances.

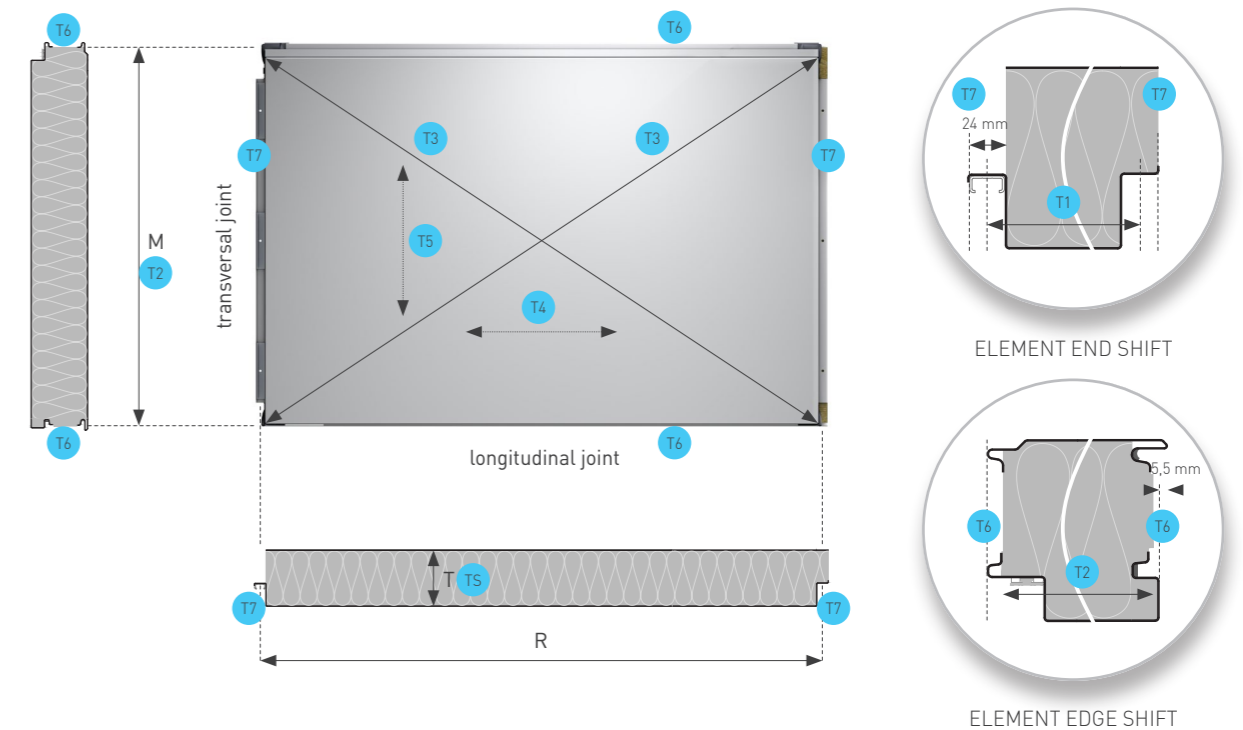

NAME	DIMENSION	TOLERANCE	VALUE (mm)	REMARKS
Element thickness	S	TS	± 2	Tolerance of element thickness
Element length < 3 m	R	T1	± 1,5	Tolerance of external steel sheet length
Element length ≥ 3 m	R	T1	± 1	Tolerance of external steel sheet length
Module width	M	T2	± 2	Tolerance of external steel sheet module width
Element cross length		T3	± 2	Deviation of external steel sheet cross length
Element flatness (longitudinal)		T4	± 0,3 ± 0,5 ± 0,7	Flatness deviation of external steel sheet surface in longitudinal direction. Measurement length: L = 200 mm L = 400 mm L = 700 mm
Element flatness (transversal)		T5	± 0,3 ± 0,5 ± 0,7	Flatness deviation of external steel sheet surface in transversal direction. Measurement length: L = 200 mm L = 400 mm L = 700 mm
Element edge shift (transversal)		T6	± 1,5	Deviation of internal / external steel sheet position
Element end shift (longitudinal)		T7	± 2	Deviation of internal / external steel sheet position





## B. ELEMENT DESCRIPTION



### THICKNESS VARIATIONS

Thickness of Qbiss One façade element is determined with respect to the client's needs and in accordance to project's individual requirements. Different thickness of Qbiss One element has a direct impact on load-bearing capacity, thermal insulation, fire resistance, and thermal stability of the façade system.

Scheme of Qbiss One element thickness variations (T - element thickness).

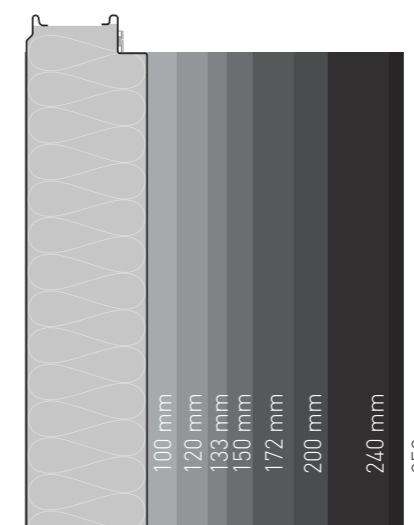

Element marking: Qbiss One T B 100 / 1000 G S

Qbiss One	T	B-B	100	1000	G	S
product name	mineral wool type	joint option	thickness (mm)	module (mm)	external steel skin profile	internal steel skin profile

## B. ELEMENT DESCRIPTION

# TECHNICAL DATA

### TECHNICAL DATA FOR QBISS ONE FAÇADE ELEMENTS

Qbiss One elements are differentiated based on type of mineral wool being used depending on thermal insulation and structural spanning requirements.

Thickness (mm)	80	100	120	133	150	172	200	240	250
Use	External walls, internal walls and ceilings								
Cover width (mm)	600 - 1200								
Length (mm)*	From 500 up to 6500								
External facing - profile	Steel sheet, stainless steel, thickness: 0.675 - 0.80; G								
Internal facing - profile	Steel sheet, stainless steel, thicknesses: 0.50 - 0.80; G, S, V, V2, M, M3								
Coating	Coating PVDF or PUR/PA								
Reaction to fire	A2-s1, d0								
Water permeability (Pa - wall)	Class A (1200)								
Air permeability [C (m³/Pa*s);n]	C = 0.0046; n = 0.970								
Water vapour permeability	Impermeable								
Airborne sound insulation: R <sub>w</sub> [C:C <sub>r</sub> ]	30 [-1;-3] (dB)								

#### CORE: POWER T

Weight (kg/m²) for 0,55mm int. skin	18.7	20.6	22.4	23.8	25.1	27.1	29.6	33.19	34.1
Ψ <sub>L</sub> - Longitudinal joint (W/m K)	0.0456	0.0243	0.0157	0.0143	0.0096	0.0072	0.0053	0.0036	0.0034
Ψ <sub>T</sub> - Transversal joint (W/m K)	0.0461	0.0266	0.0176	0.0141	0.0110	0.0082	0.0058	0.0041	0.0038
U - Thermal transmittance (W/m² K)*	0.46	0.37	0.31	0.28	0.25	0.22	0.19	0.16	0.15

#### CORE: POWER S

Weight (kg/m²) for 0,55mm int. skin	20.6	22.9	25.2	27.0	28.6	31.2	34.3	38.9	40.0
Ψ <sub>L</sub> - Longitudinal joint (W/m K)	0.067	0.032	0.020	0.016	0.012	0.009	0.007	0.005	0.004
Ψ <sub>T</sub> - Transversal joint (W/m K)	0.050	0.029	0.019	0.015	0.012	0.009	0.006	0.005	0.005
U - Thermal transmittance (W/m² K)*	0.50	0.41	0.34	0.31	0.28	0.24	0.21	0.17	0.17

#### CORE: PERFORM C

Weight (kg/m²) for 0,55mm int. skin	21.1	23.5	25.9	27.8	29.5	32.2	35.5	40.3	41.5
Ψ <sub>L</sub> - Longitudinal joint (W/m K)	0.067	0.032	0.020	0.016	0.012	0.009	0.006	0.005	0.004
Ψ <sub>T</sub> - Transversal joint (W/m K)	0.049	0.029	0.019	0.015	0.012	0.009	0.006	0.004	0.004
U - Thermal transmittance (W/m² K)*	0.49	0.40	0.33	0.30	0.27	0.24	0.20	0.17	0.16

\* To get an exact Qbiss One thermal transmittance, use the following formula:  $U_{TOTAL} = (U \times Area_{element} + \Psi_L \times Length_{element} + \Psi_T \times Width_{element}) / Area_{element}$   
The minimum Qbiss One length is set to 550 mm and maximum Qbiss One length to 6475 mm for the element types: 5, 6, 7, 8, 9, 10, 11, 12.

! For French and German market consult Trimmo's technical support team to comply with regional legislation.



650a to LPS 1208  
650d to LPS 1181



EPD  
EN 15804  
VERIFIED

## B. ELEMENT DESCRIPTION

### THERMAL TRANSMITTANCE

Qbiss One modular façade system was designed to provide a comfortable living environment in accordance with the requirements of physical construction conditions in buildings. A stationary heat transfer calculation was made using the numerical modelling method in accordance with the guidelines and recommendations for heat transfer calculations, provided in standard EN 14509.

Demonstration of the established temperature field in the longitudinal and transversal joints

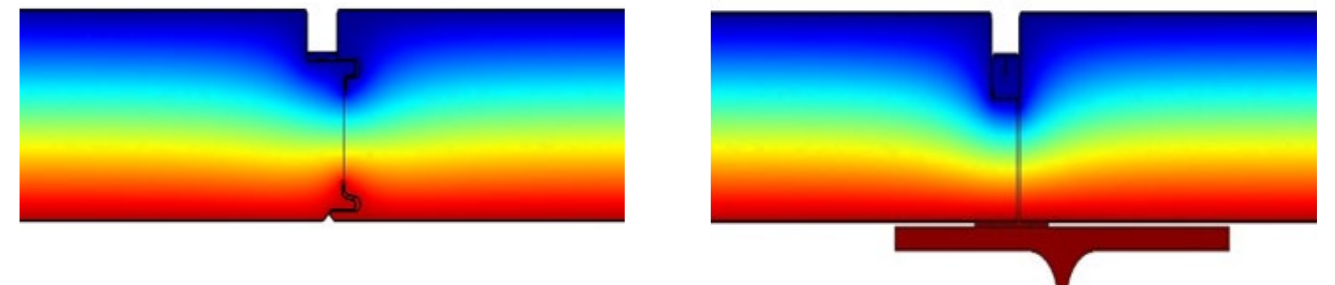

### FIRE SAFETY

Fire terminology is frequently misunderstood and misused within the construction industry. A material or product's performance in fire conditions can be categorised in many different ways. Some categories are genuine regulatory levels issued by approved authorities while others are claims made by manufacturers whose self-generated terminologies are used to apply an enhanced level of fire safety to a material or product. All requests for fire safety must be clearly specified by customer.

Investigations into recent building fires have highlighted the need to investigate all the materials that make up a composite element. Extracts from the report include the following statements:

#### FACTORY MUTUAL (FM)

Trimmo products have received FM4880 and FM4881 certification.

#### LOSS PREVENTION CERTIFICATION BOARD (LPCB)

LPCB is a major certification issuing board in the United Kingdom. Product is certified under LPS1208 (fire resistance of constituent materials) and LPS1181 (spread of flame) for fire resistance performance.



**FIRE RESISTANCE FOR HORIZONTALLY INSTALLED QBISS ONE ELEMENTS (i->o)**

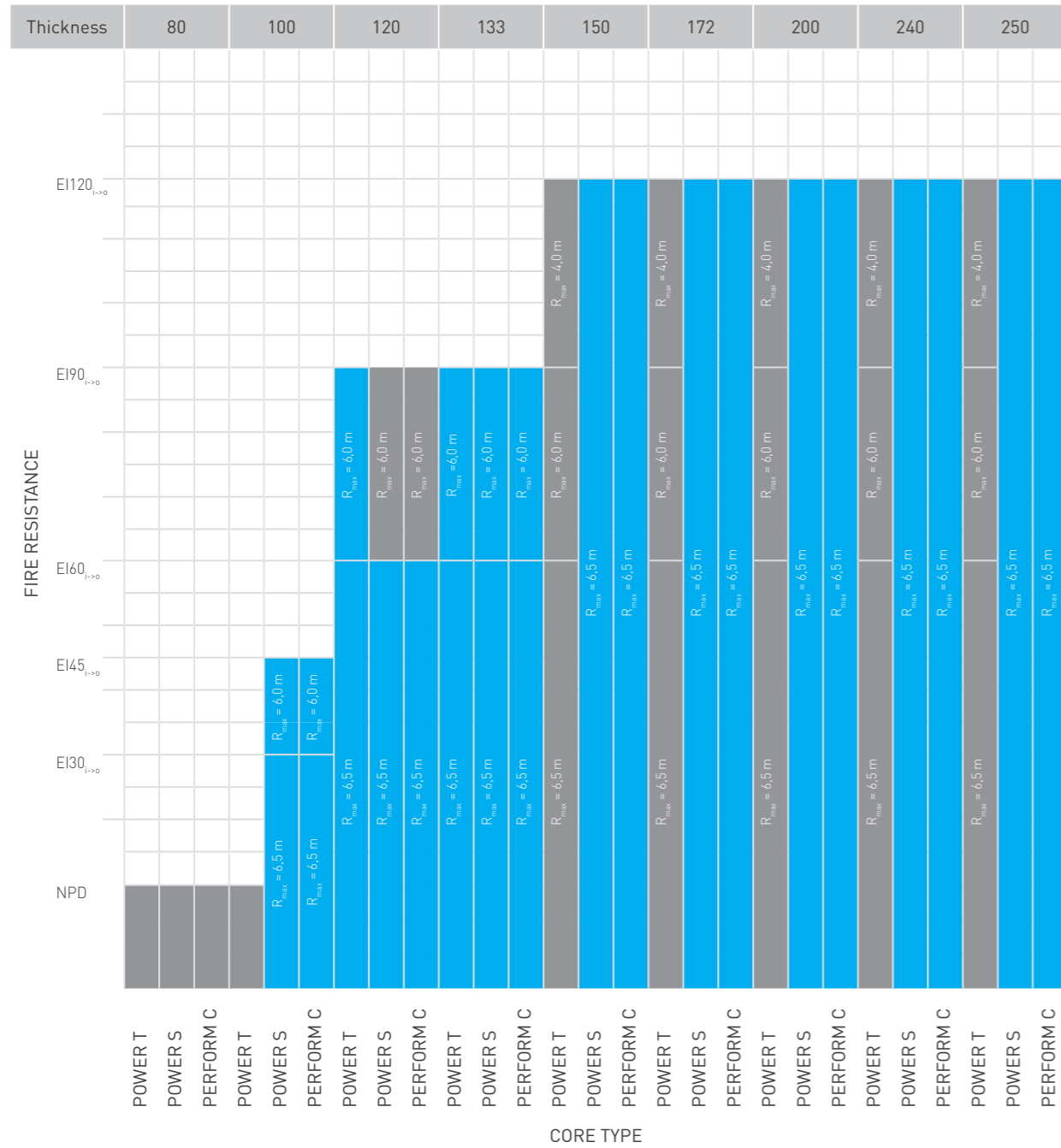

According to classification standard EN 13501-2: 2016.  
 Tests were made using basic rectangular elements, with fire spreading from inside of the building towards the outside (i->o).  
[According to extended application \[EXAP\] standards EN 15254-5: 2018.](#)

**FIRE RESISTANCE FOR VERTICALLY INSTALLED QBISS ONE ELEMENTS (i->o)**

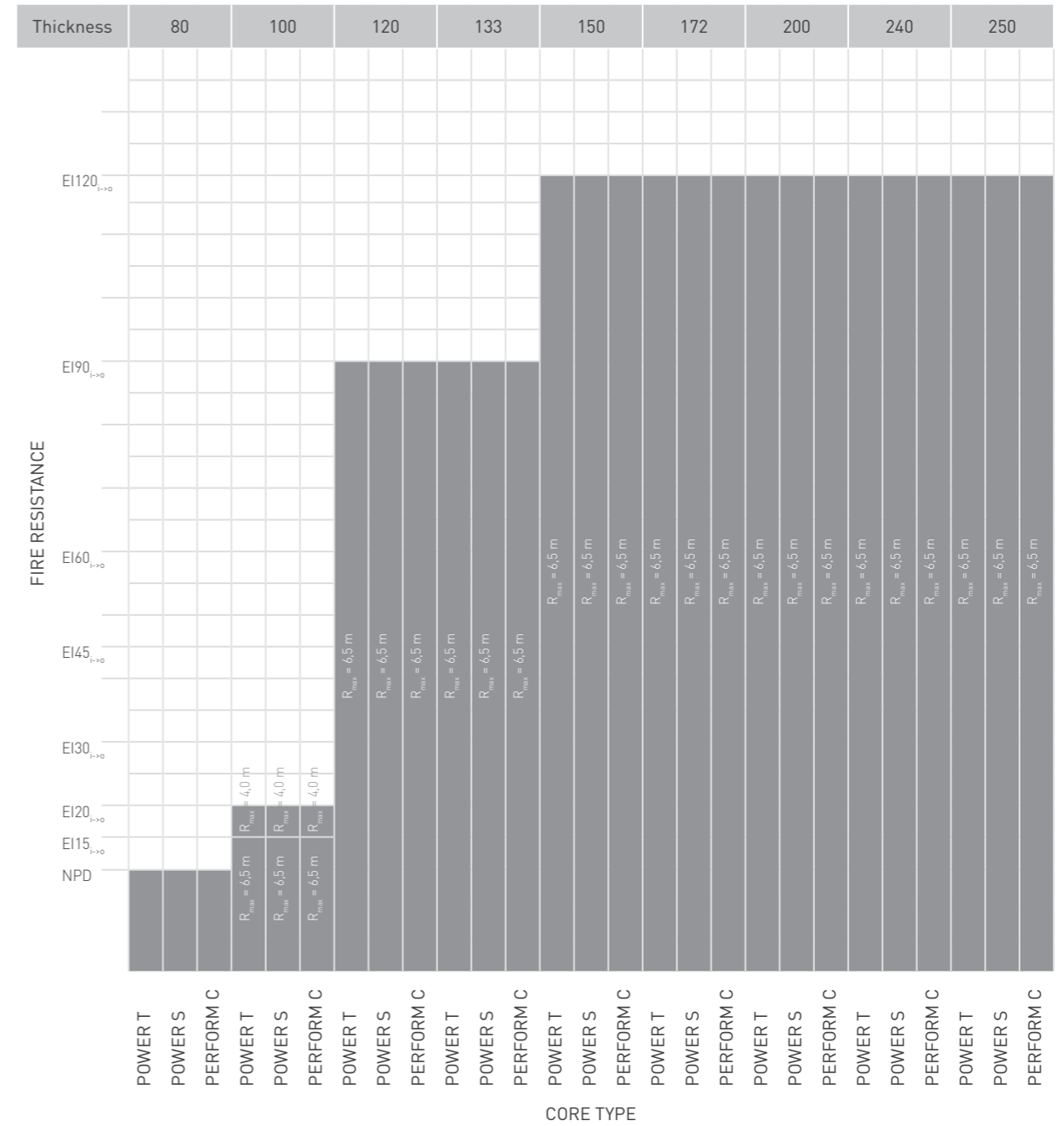

According to classification standard EN 13501-2: 2016.  
 Tests were made using basic rectangular elements, with fire spreading from inside of the building towards the outside (i->o).

**FIRE RESISTANCE FOR HORIZONTALLY INSTALLED QBISS ONE ELEMENTS (o->i)**

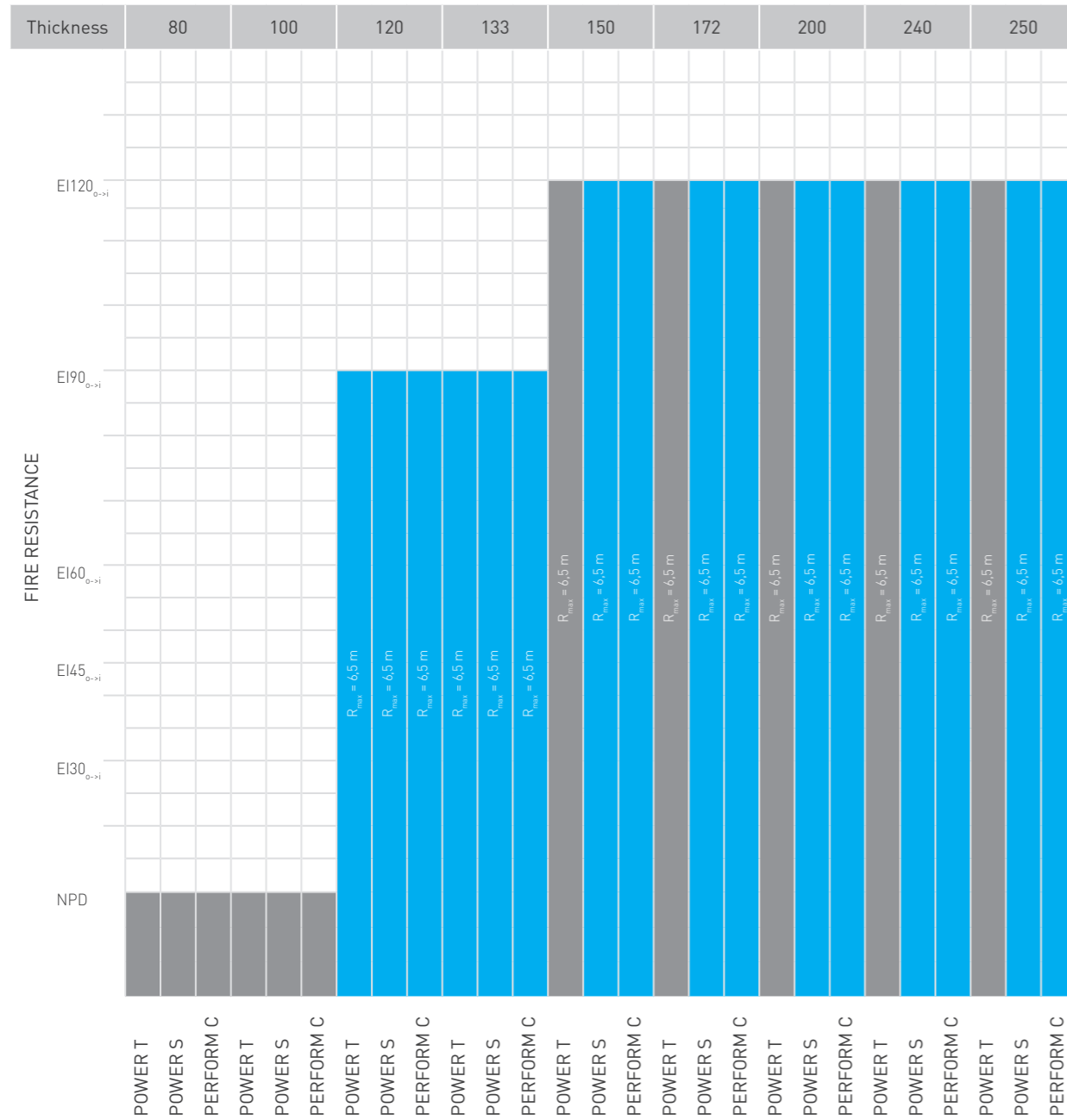

According to classification standard EN 13501-2: 2016.  
 Tests were made using basic rectangular elements, with fire spreading from outside of the building towards the inside (o->i).  
 According to extended application [EXAP] standards EN 15254-5: 2018.

**FIRE RESISTANCE FOR VERTICALLY INSTALLED QBISS ONE ELEMENTS (o->i)**

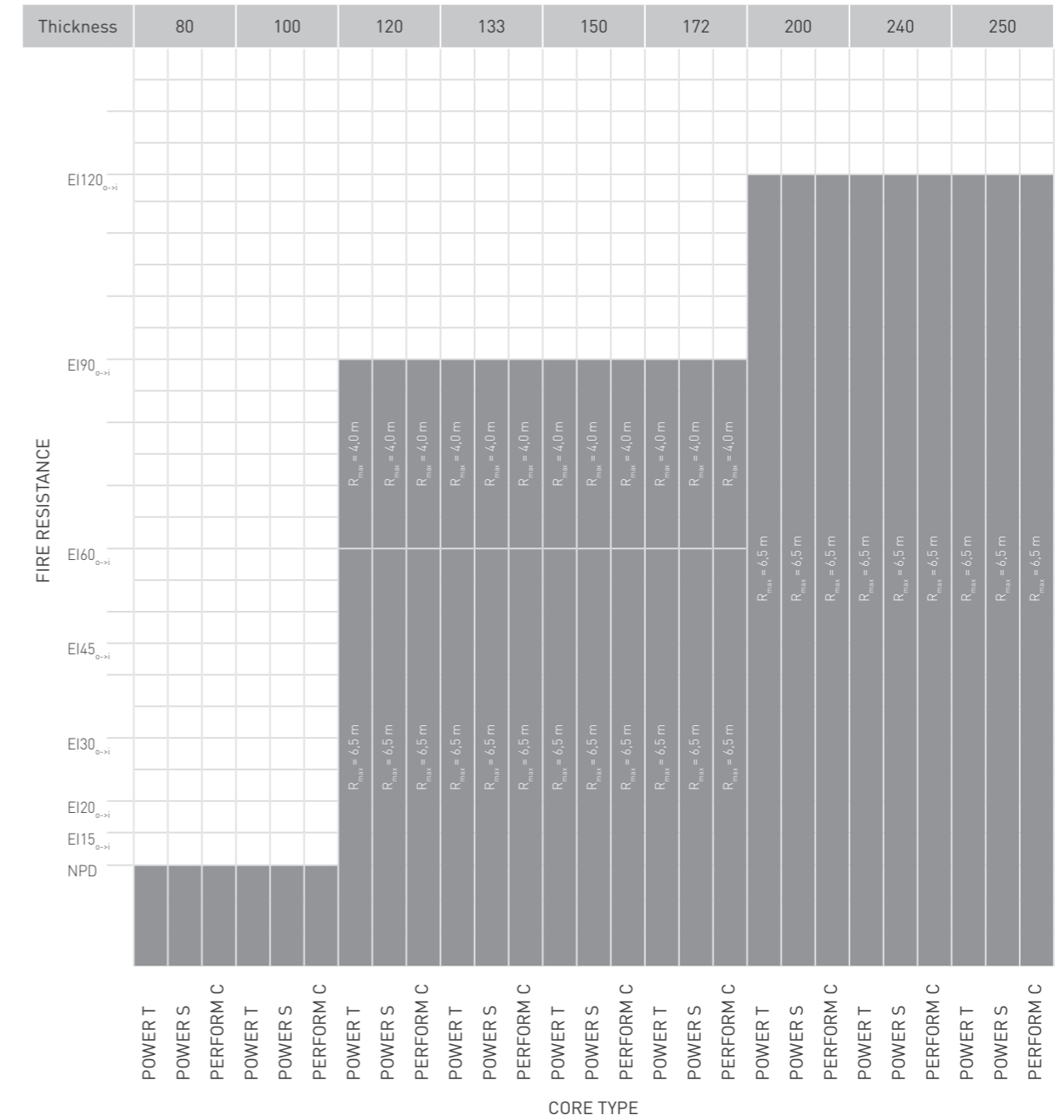

According to classification standard EN 13501-2: 2016.  
 Tests were made using basic rectangular elements, with fire spreading from outside of the building towards the inside (o->i).



## C. ACCESSORIES

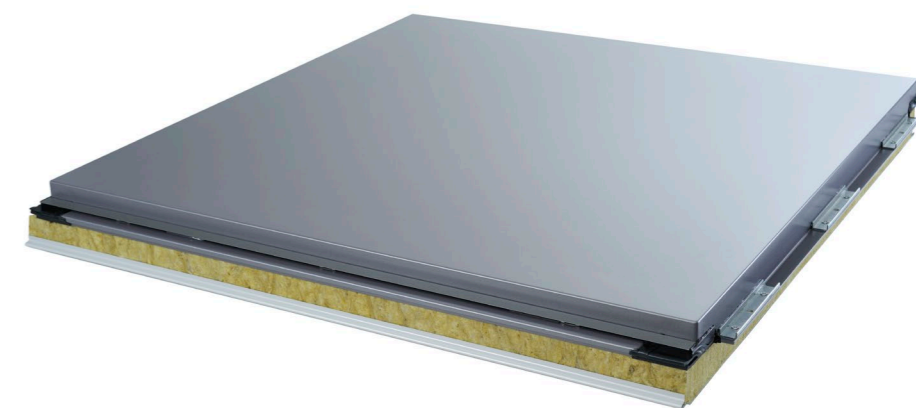

# C. ACCESSORIES DECORATIVE ELEMENTS

## ALUMINIUM EXTRUSIONS

The range and the variety of decorative elements capture our attention and charm us with the luxuriously decorated façades. Set of our aluminium decorative elements is powder painted to match the colour of your façade or you can choose a colour you wish.

Discover Trimo decorative elements.

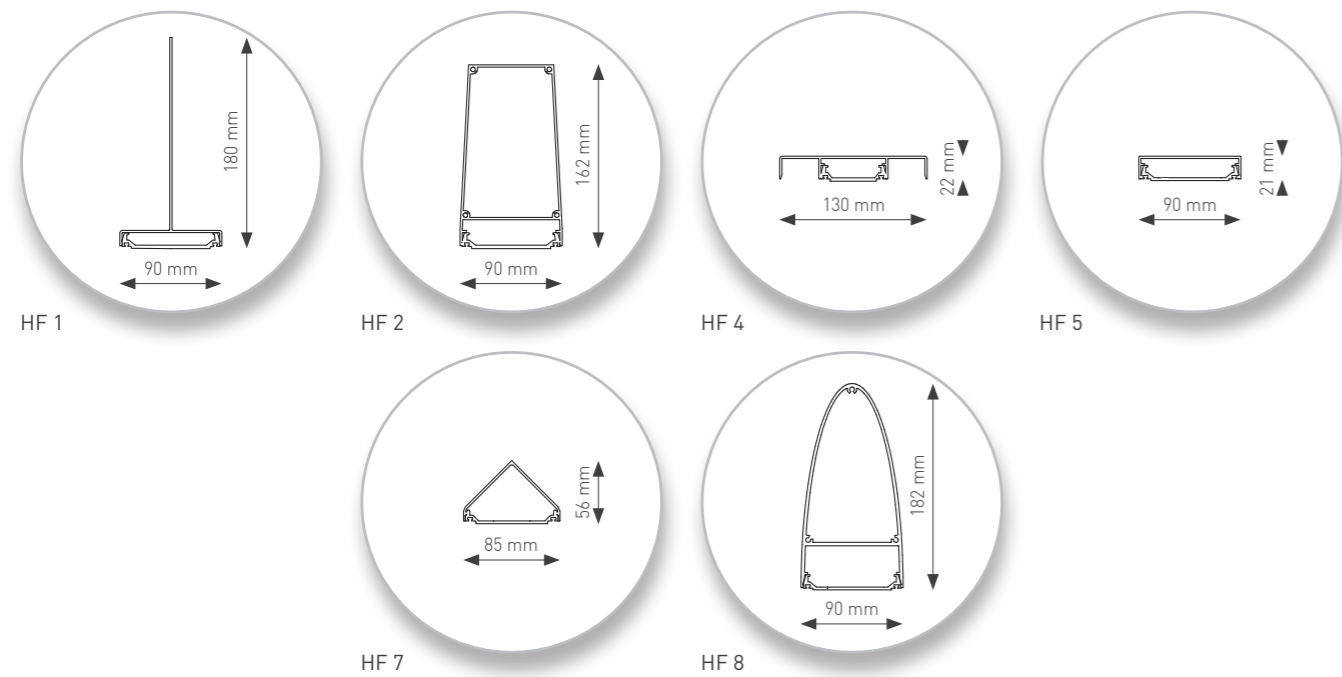

# C. ACCESSORIES

## CORNER ELEMENTS

### UNIQUENESS OF QBISS ONE ELEMENTS

Prefabrication is the uniqueness of Qbiss One. In addition to rectangular elements, we produce corner elements as well as corner elements connecting two different façades or a façade prolonging directly into a soffit. While designing, you need to take into consideration our production limitations.

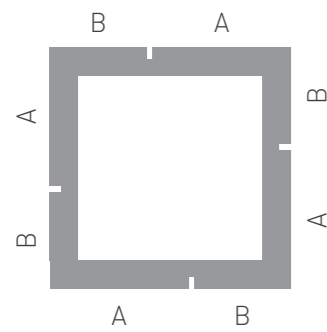

The principle for designating the sides of corner elements shown is a plan view of four corners of a building with side designations.

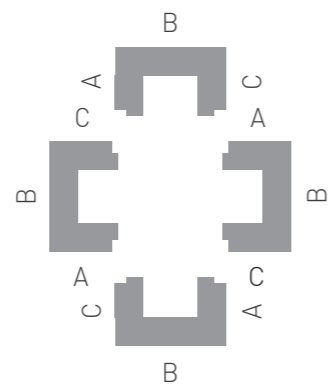

The principle for designating the sides of U-corner elements shown is a plan view of four corners of a building with side designations.

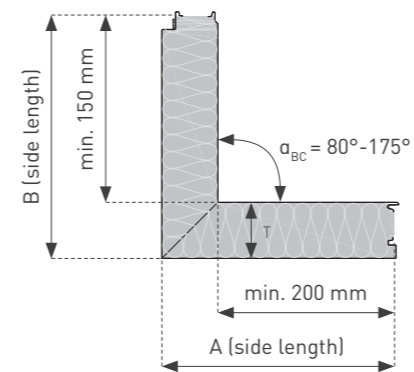
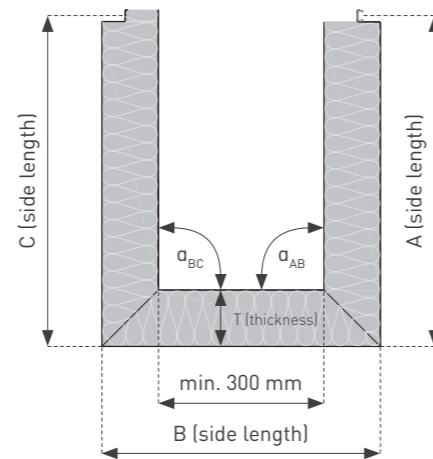
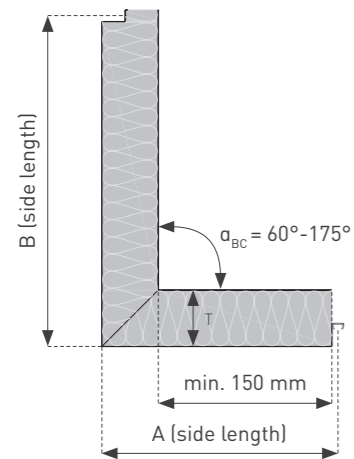

Qbiss One transversal and U shaped corner element.

# C. ACCESSORIES



Qbiss One longitudinal corner element completing building envelope.

Qbiss One longitudinal corner element.

- ! All variations of corner elements are produced out of a flat Qbiss One elements. Finalization of each corner is performed outside robotized production train, therefore minor deviation in product tolerances, surface inconsistencies and local change in appearance might occur.
- Direction of installation and the element type do not affect the designation of legs (A, B, C) of the corner element.
- Scheme for designating the legs is shown on the previous page, C 1.3.

**TRANSVERSAL CORNER ELEMENT LIMITATIONS**

Restrictions on the length of the corner elements sides

- $\alpha_{AB} = 60^\circ - 175^\circ$
- $A (B) \leq 600 \text{ mm}; (A+B)_{\max} \leq 3100 \text{ mm}$
- $A (B) > 600 \text{ mm}; (A+B)_{\max} \leq 2000 \text{ mm}$
- $A_{\min} (B_{\min}) = (150 \text{ mm} + T); A+B > 500 \text{ mm}$

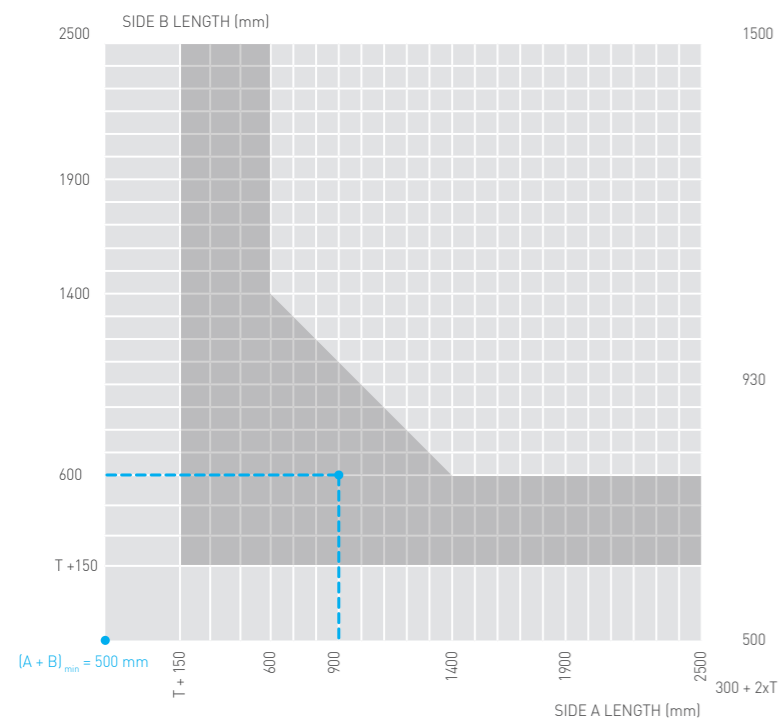

**TRANSVERSAL U-CORNER ELEMENT LIMITATIONS**

Restrictions on the length of the U-corner elements sides

- $150 \text{ mm} + T \leq A_{\min} (C_{\min}) \leq 1000 \text{ mm}$
- $300 \text{ mm} + 2 \times T \leq B \leq 1500 \text{ mm}$
- $\alpha_{AB} (\alpha_{BC}) = 90^\circ - 175^\circ$

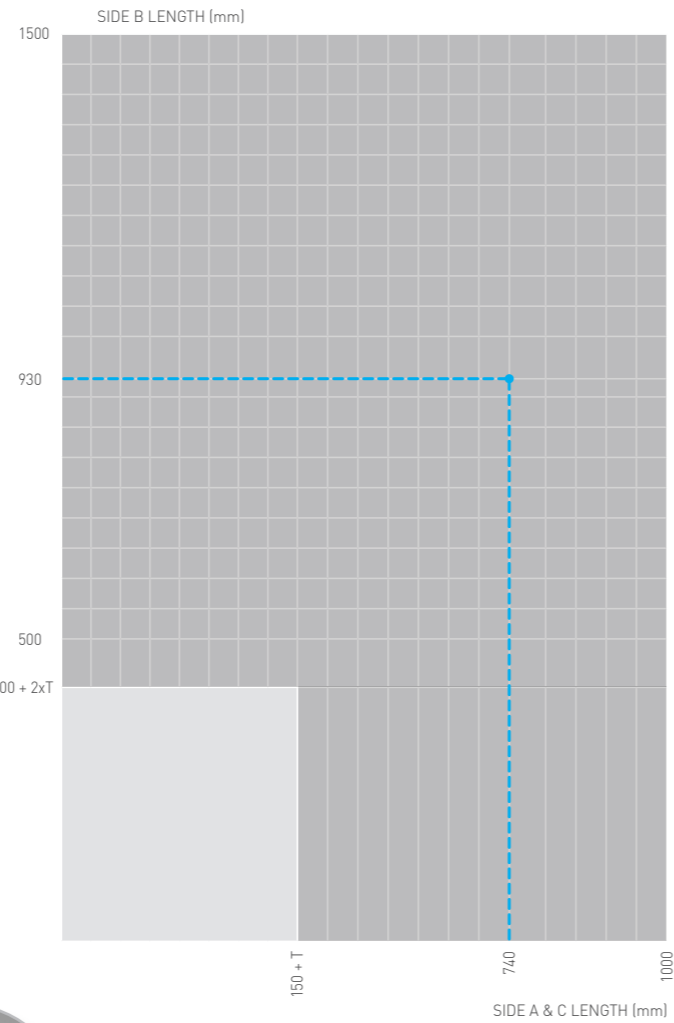

**LONGITUDINAL CORNER ELEMENT LIMITATIONS**

Restrictions on the length of the corner elements sides

- $\alpha_{AB} = 80^\circ - 175^\circ$
- $A_{\min} \geq (200 \text{ mm} + T)$
- $B_{\min} \geq (150 \text{ mm} + T)$
- $600 \text{ mm} \leq (A + B) \leq 1200 \text{ mm}$
- $500 \text{ mm} \leq R \leq 6500 \text{ mm}$

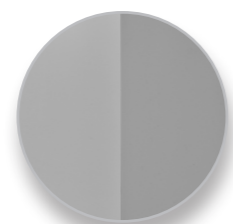
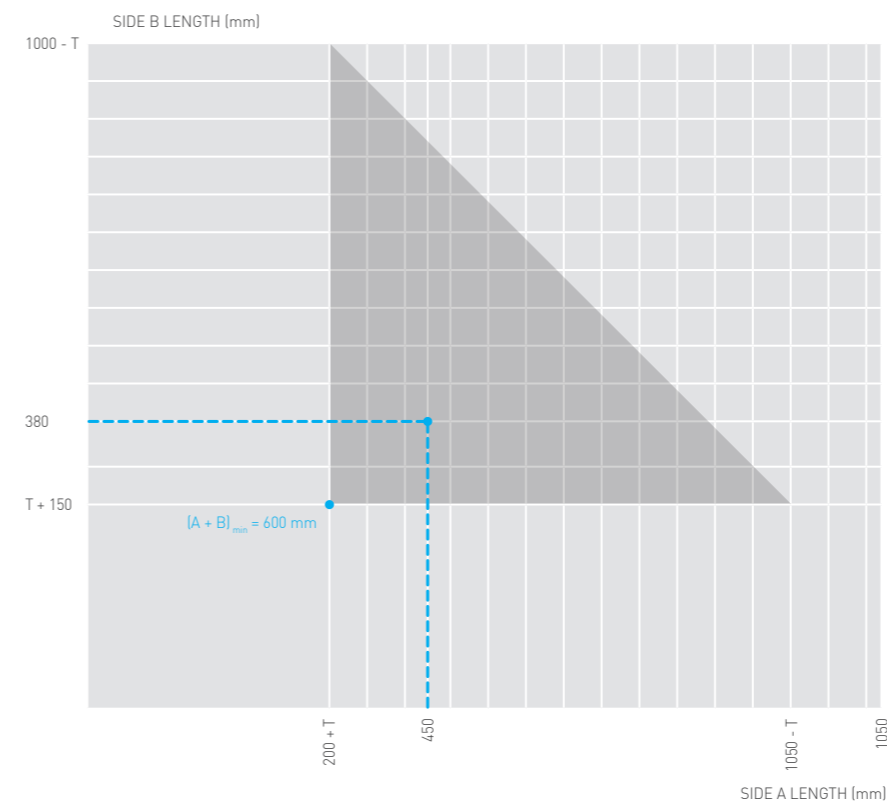

CORNER EDGE CONNECTION

- R - Design length
- M - Module width
- T - Qbiss One element thickness

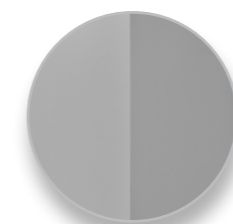

! Visually, there is a difference between corner element and spliced corner element.



**TRANSVERSAL SPLICED CORNER LIMITATIONS**

Restrictions on the length of the corner elements sides

- $\alpha_{AB} = 60^\circ - 175^\circ$
- $A (B) \leq 600 \text{ mm}; B_{\max} (A_{\max}) \leq 2500 \text{ mm}$
- $A (B) > 600 \text{ mm}; (A+B)_{\max} \leq 2000 \text{ mm}$
- $A_{\min} (B_{\min}) = (150 \text{ mm} + T); A+B > 500 \text{ mm}$

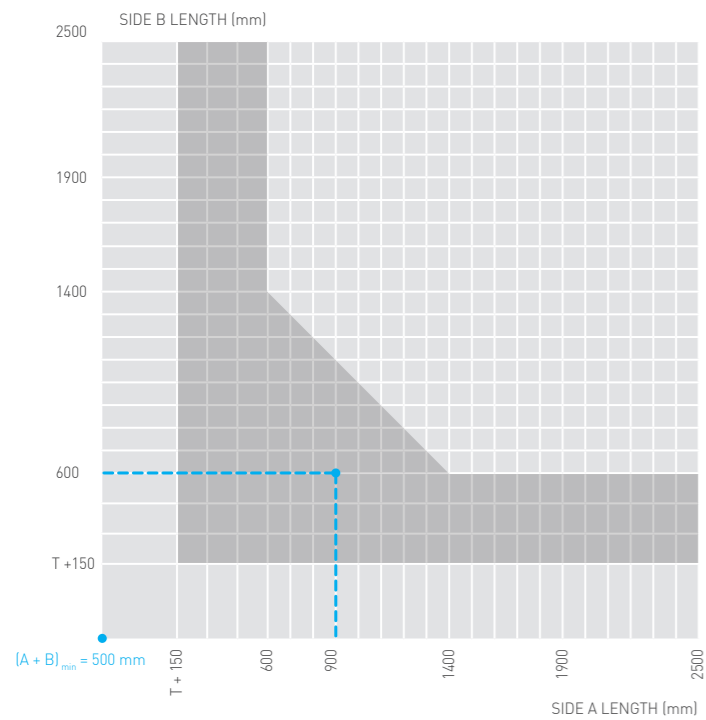
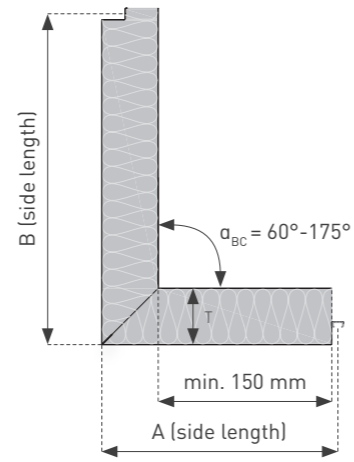

**LONGITUDINAL SPLICED CORNER LIMITATIONS**

Restrictions on the length of the corner elements sides

- $\alpha_{AB} = 70^\circ - 175^\circ$
- $T = 80 \text{ mm}, 100 \text{ mm}, 120 \text{ mm}, 133 \text{ mm}, 150 \text{ mm}$
- $600 \text{ mm} < M < 1200 \text{ mm}$
- $500 \text{ mm} < R < 6500 \text{ mm}$
- $A_{\min} (B_{\min}) = 150 \text{ mm} + T; B_{\min} (A_{\min}) = 200 \text{ mm} + T$
- $A_{\max} = B_{\max} = 800 \text{ mm}$

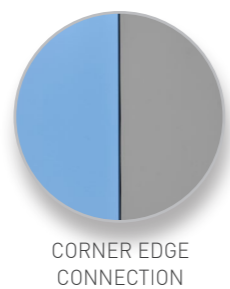
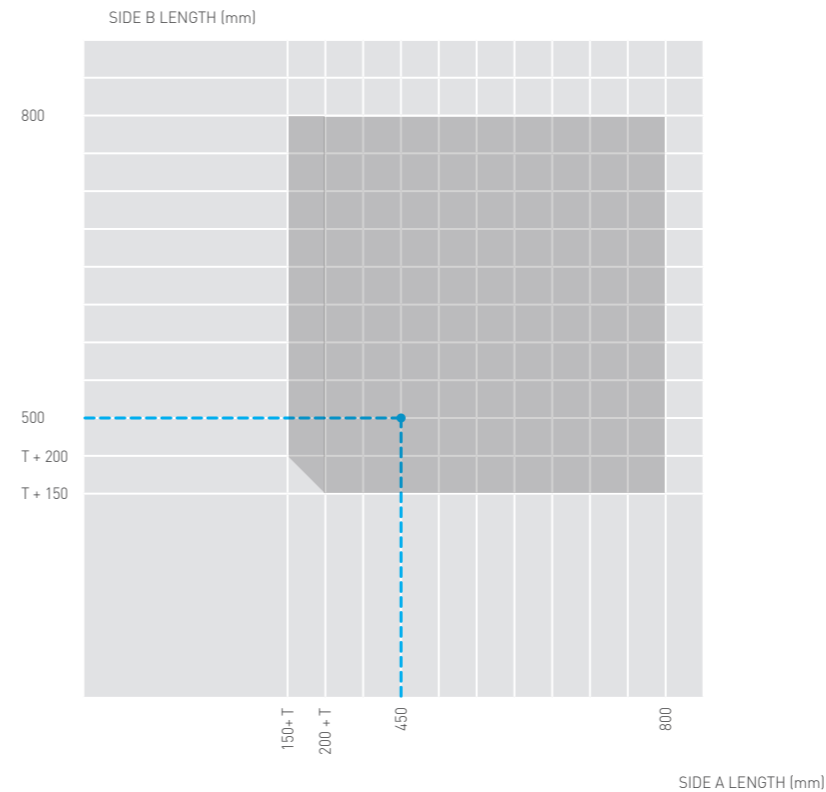
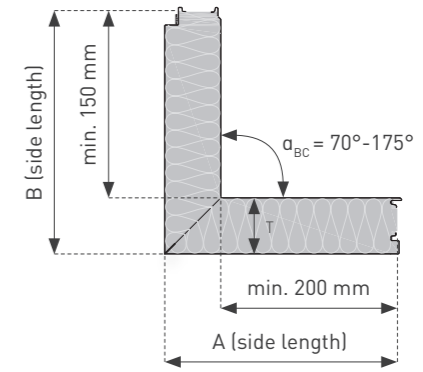

CORNER EDGE CONNECTION

- R - Design length
- M - Module width
- T - Qbiss One element thickness

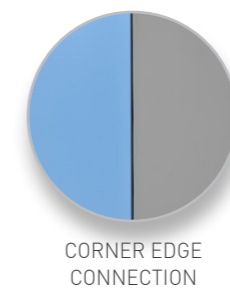

CORNER EDGE CONNECTION

! Visually, there is a difference between corner element and spliced corner element. Transversal spliced corner elements are made from 2 separate Qbiss One elements. The colour of each corner side can be individually selected.

**TRANSVERSAL INCLINED CORNER LIMITATIONS**

Restrictions on the length of the corner elements sides

- $\alpha_{B'M'} = 80^\circ - 135^\circ$
- $\alpha_{AB} = 70^\circ - 175^\circ$
- $80 \text{ mm} < T < 250 \text{ mm}$
- $600 \text{ mm} < M \text{ \& } M' < 1200 \text{ mm}$  (2 different widths)

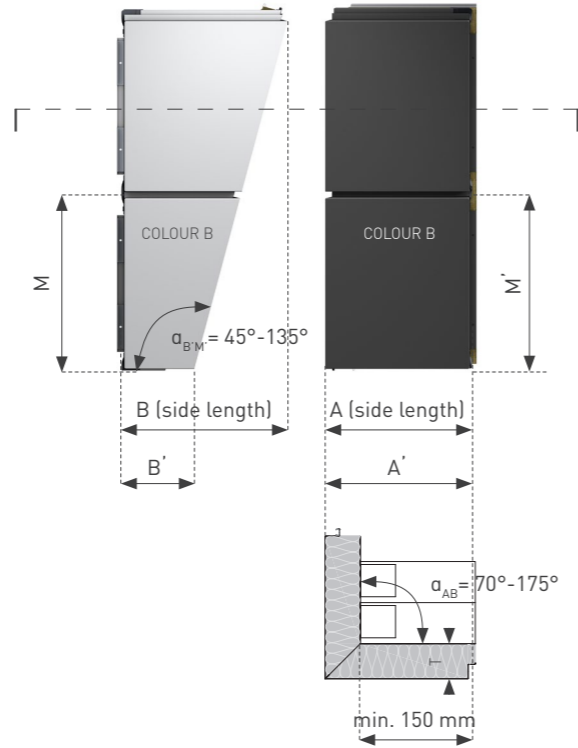
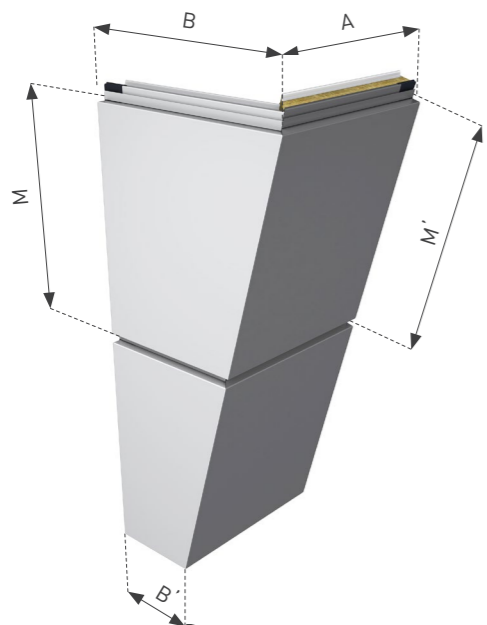
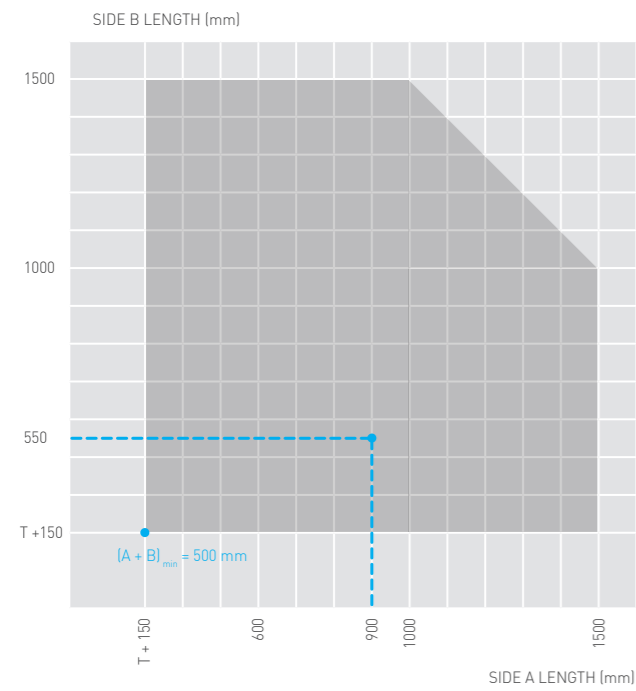

R - Design length  
M - Module width  
T - Qbiss One element thickness

**LONGITUDINAL INCLINED CORNER LIMITATIONS**

Restrictions on the length of the corner elements sides

- $\alpha_{B'R'} = 80^\circ - 135^\circ$
- $\alpha_{AB} = 70^\circ - 175^\circ$
- $\alpha_{A'R'} = 90^\circ$
- $T = 80 \text{ mm}, 100 \text{ mm}, 120 \text{ mm}, 133 \text{ mm}, 150 \text{ mm}$
- $600 \text{ mm} < M < 1200 \text{ mm}$
- $500 \text{ mm} < R, R' < 6500 \text{ mm}$  (different lengths)
- $(A + B)_{\text{max}} = 600 \text{ mm}$

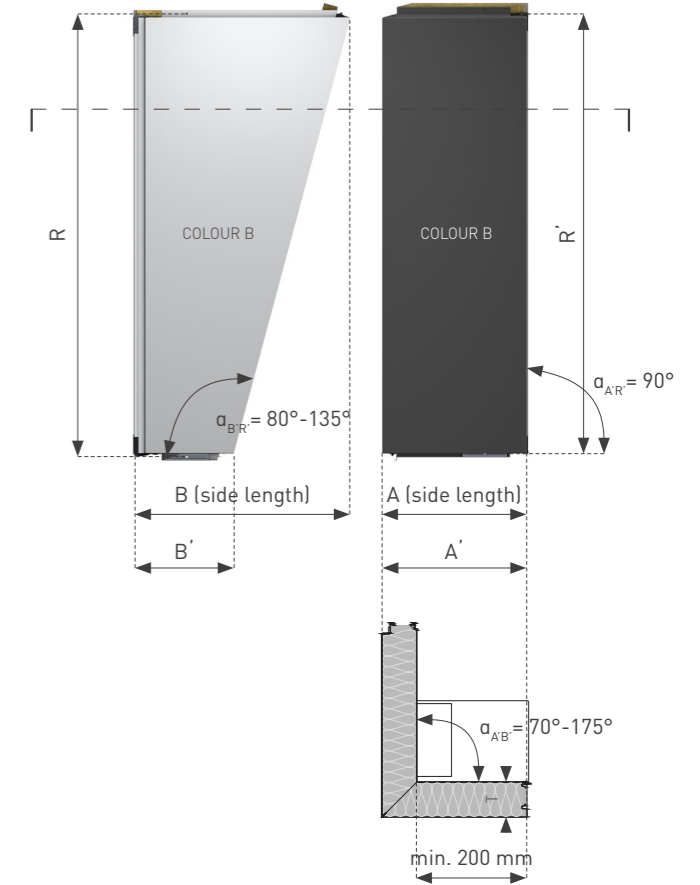
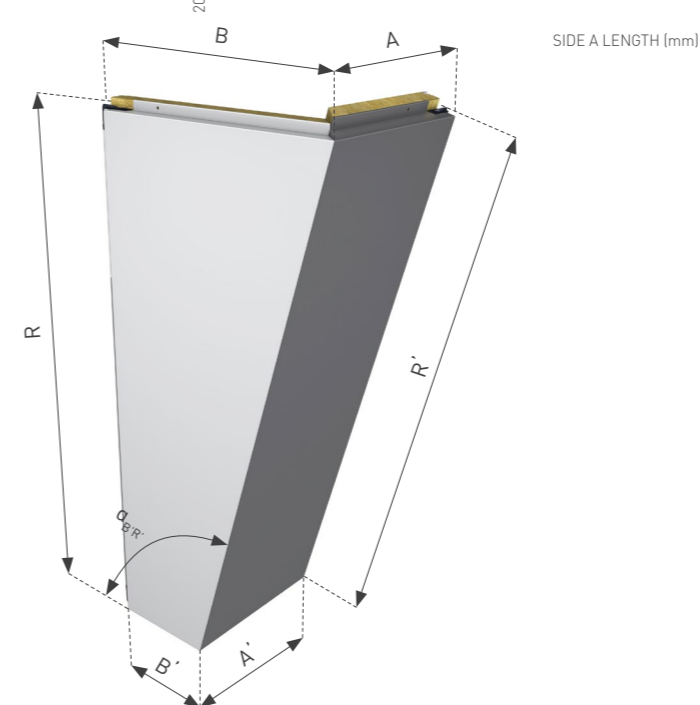
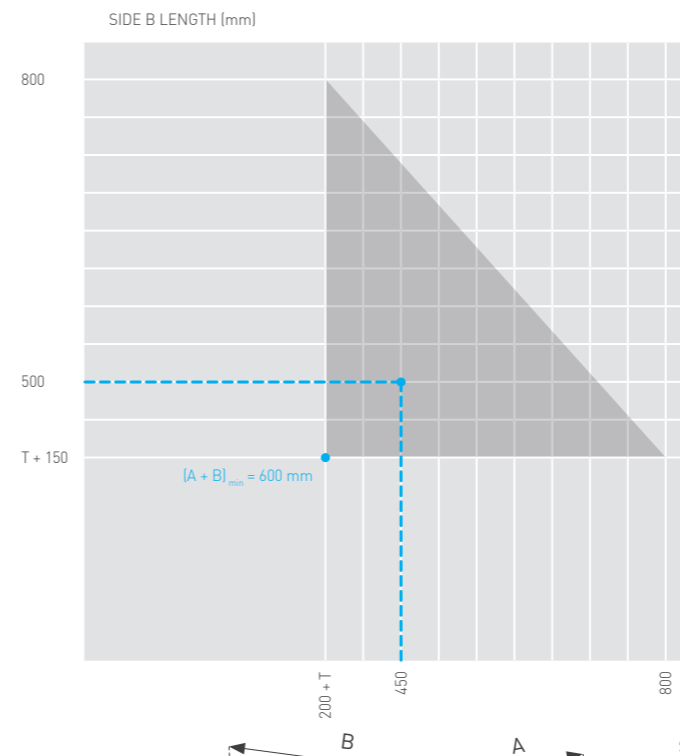

# 3D CORNER ELEMENTS

## OUTSTANDING FEATURE OF QBISS ONE ELEMENTS

Qbiss One 3D corner is an outstanding element. Not only does it connect two façades, but at the same time it transforms it into a soffit. All those features are found within a single Qbiss One corner element.



3D corner element was developed in a way that a single Qbiss One corner element is laid horizontally and folded by 45° angle in the transversal direction. This allows façade to pass smoothly into a soffit in one piece. 3D corner elements are possible within horizontal and vertical Qbiss One system.

### DISCLAIMER

All variations of Qbiss One corner elements are produced out of a flat Qbiss One elements. Each corner is finalized outside robotized production train, therefore minor deviation in product tolerances, surface inconsistencies and local change in appearance might occur.

## 3D DIAGONAL CUT - CORNER ELEMENT

Basic length restrictions

- $A + B = M$  [mm]
- $600 \text{ mm} < A + B < 1200 \text{ mm}$
- $R_1 + R_2 = R$  [mm]
- $2 \times T + 470 \text{ mm} < R < 2000 \text{ mm}$
- $\alpha_{AB} = 90^\circ$
- $90^\circ < \alpha_{R_1 R_2} < 175^\circ$

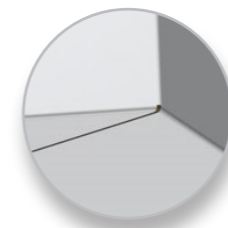
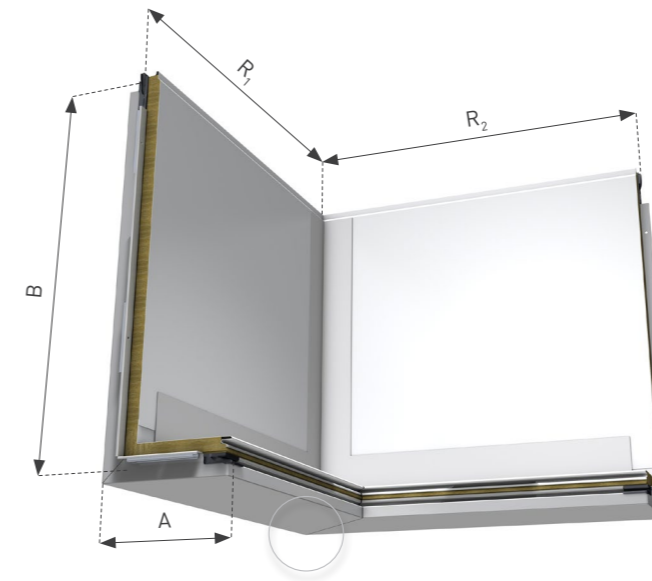

DIAGONAL CUT

## 3D EDGE CUT - CORNER ELEMENT

Basic length restrictions

- $A + B = M$  [mm]
- $600 \text{ mm} < A + B < 1200 \text{ mm}$
- $R_1 + R_2 = R$  [mm]
- $2 \times T + 470 \text{ mm} < R < 2000 \text{ mm}$
- $\alpha_{AB} = 90^\circ$
- $90^\circ < \alpha_{R_1 R_2} < 175^\circ$

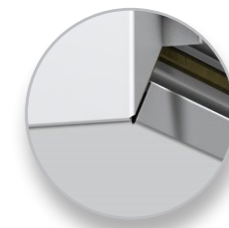
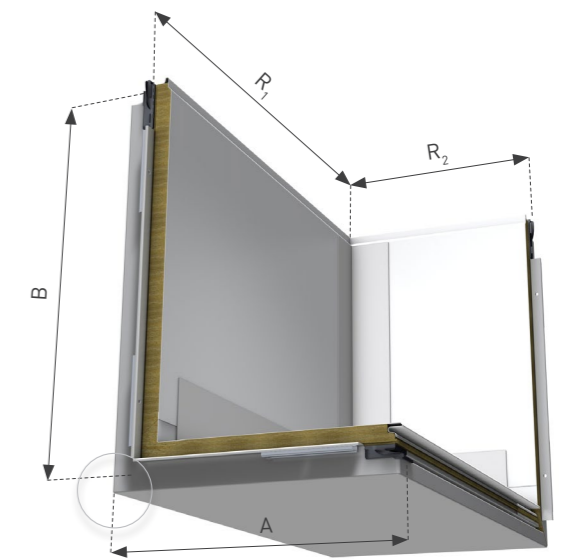

EDGE CUT

- R – Design length
- $R_1 + R_2$  – Design length
- $A + B$  – Module width
- M – Module width
- T – Qbiss One element thickness

! Corner reinforcement profiles dimensions depend on minimal cut-outs of individual thicknesses and corner angles. Sealing of cut-out joints is performed with the use of mastic seal, additional steel sheet pieces, stripes and rivets. The joint offers the level of protection equal to rounded corner of Qbiss One element.

**3D DIAGONAL CUT - CORNER ELEMENT**

Learn more about 3D corner element system at:

[🌐 CAD download centre](#)



3D diagonal cut corner element right side view

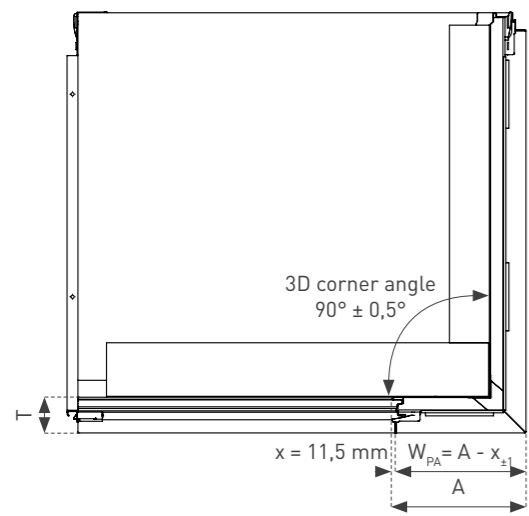

3D diagonal cut corner element left side view

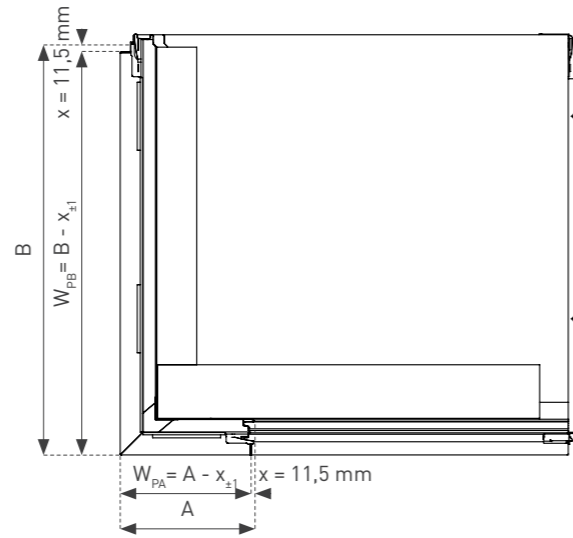

T [mm]	A <sub>min</sub> (B <sub>min</sub> )	A <sub>max</sub> (B <sub>max</sub> )	R <sub>1 min</sub> (R <sub>2 min</sub> )	R <sub>1 max</sub> (R <sub>2 max</sub> )
80	315	885	515	1000
100	335	865	535	1000
120	355	845	555	1000
133	368	832	568	1000
150	385	815	585	1000
172	407	793	607	1000
200	435	765	635	1000
240	475	725	675	1000

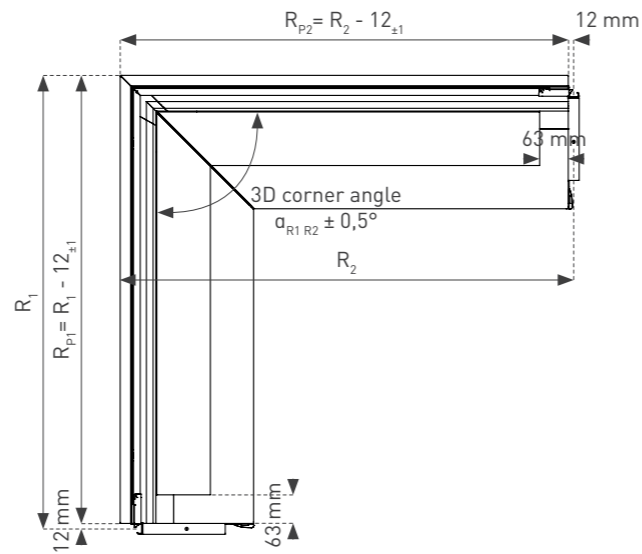

3D diagonal cut corner element top view

R - Design length  
M - Module width  
T - Qbiss One element thickness

**3D EDGE CUT - CORNER ELEMENT**

3D edge cut corner element right side view

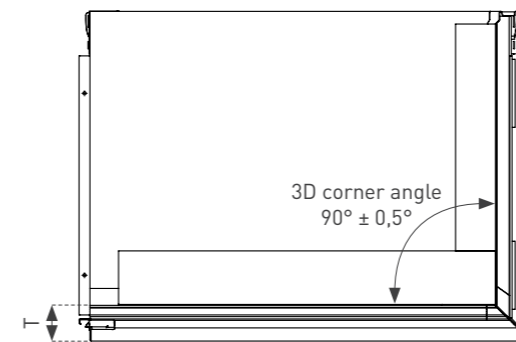

3D edge cut corner element left side view

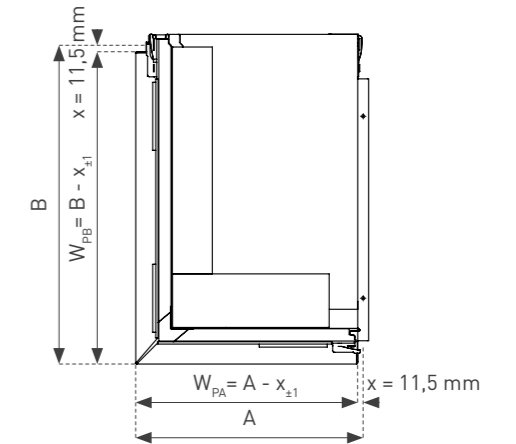

T [mm]	A <sub>min</sub> (B <sub>min</sub> )	A <sub>max</sub> (B <sub>max</sub> )	R <sub>1 min</sub> (R <sub>2 min</sub> )	R <sub>1 max</sub> (R <sub>2 max</sub> )
80	315	885	315	1000
100	335	865	335	1000
120	355	845	355	1000
133	368	832	368	1000
150	385	815	385	1000
172	407	793	407	1000
200	435	765	435	1000
240	475	725	475	1000

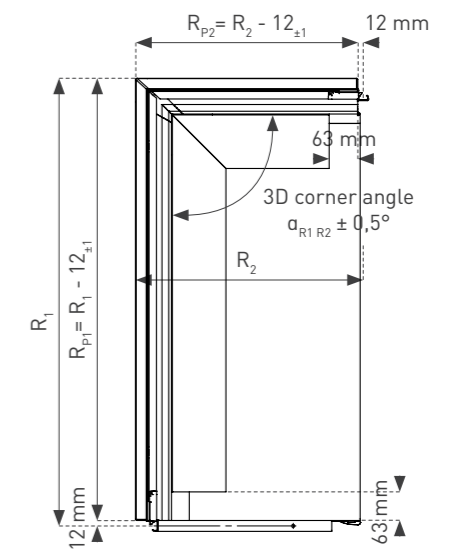

3D edge cut corner element top view

R - Design length  
M - Module width  
T - Qbiss One element thickness

**!** All applications and dimensions must be consulted and approved by Trimo's technical support team.

# 🏠 C. ACCESSORIES

## CURVED ELEMENTS

### CURVED QBISS ONE ELEMENTS

Façade with curved elements gives us the first clue that structure has something special to offer. A cool façade is a representation of the architect's creative vision and desire to impress with something unique and out of the ordinary. Qbiss One comes in 2 different types of curved elements: mould-curved and segmentally-curved.

#### TRANSVERSAL CURVED ELEMENT LIMITATIONS

- Radius -  $r$  [m]:  $\geq 4$  m
- Thickness -  $T$  [mm]: 80 - 250 mm
- Length -  $R$  [m]: 0,53 - 4 m
- Form: Convex & Concave
- Performance: retained thermal insulation, sound insulation
- Consultancy: necessary data for each project ( $r$ ,  $T$ ,  $R$  project performance demands)

#### LONGITUDINAL CURVED ELEMENT LIMITATIONS

- Radius -  $r$  [m]:  $\geq 4$  m
- Thickness -  $T$  [mm]: 80 - 250 mm
- Length -  $R$  [m]: 0,53 - 5,7 m
- Form: Convex & Concave
- Performance: retained thermal insulation, sound insulation
- Consultancy: necessary data for each project ( $r$ ,  $T$ ,  $R$  project performance demands)

convex or concave

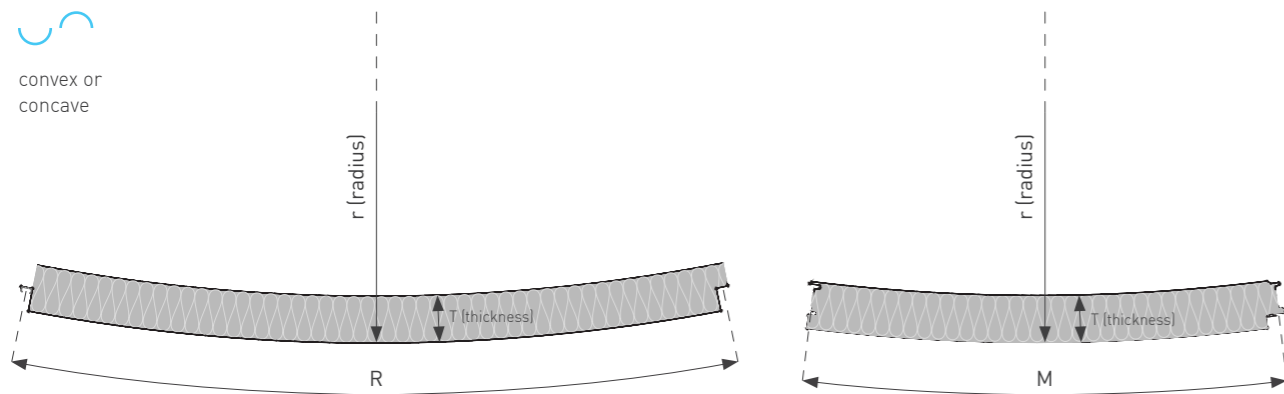

Qbiss One transversally and longitudinally curved element. Both available in convex or concave form.

**SEGMENTALLY CURVED ELEMENT LIMITATIONS**

Segmentally curved Qbiss One elements are more cost-effective solution than a curved façade. Design suggests that every second element should have slightly curved fixing point. Table below explains the radius (m) vs. length of the element (mm).

Element Length	530 mm	1000 mm	1500 mm	2000 mm	2500 mm	3000 mm	3500 mm
min. radius	10,2 m	19,3 m	28,8 m	38,4 m	47,9 m	57,5 m	67,0 m

Element Length	4000 mm	4500 mm	5000 mm	5500 mm	6000 mm	6500 mm
min. radius	76,6 m	86,1 m	95,7 m	105,2 m	114,8 m	124,3 m

**DISCLAIMER**

Radius is always measured to external steel sheet line. All variations of Qbiss One segmentally curved elements are produced out of a flat Qbiss One elements. Each element is finalized outside robotized production train, therefore minor deviation in product tolerances, surface in-consistencies and local changes in appearance might occur.

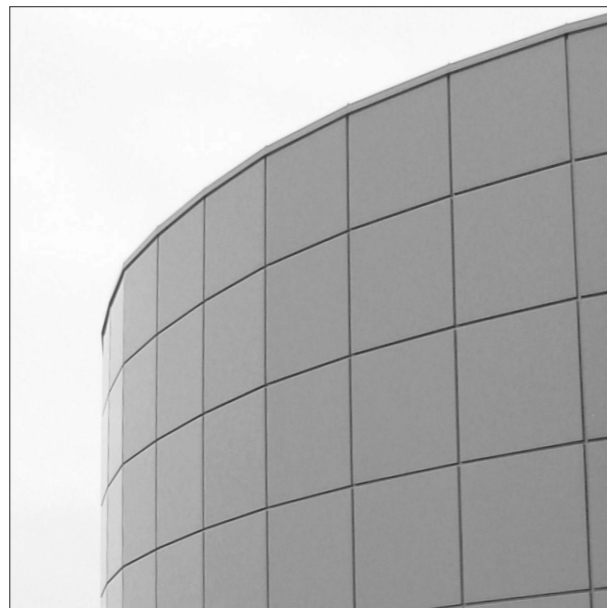
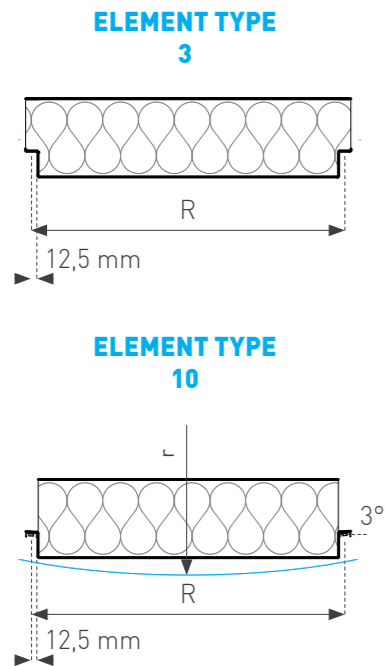

C. ACCESSORIES  
**TRAPEZOIDAL ELEMENTS**

QBISS ONE NON-ORTHOGONAL ELEMENTS

In geometry a trapezoid is a four-sided shape with two sides that are parallel. Imagine taking an equilateral triangle and chopping its tip off so that it's made up of two parallel lines on top and bottom and you've got a trapezoid. We are sure you already knew those things, but did you know we can produce trapezoid-shaped Qbiss One elements?

Qbiss One trapezoidal elements use transversal joint under non-orthogonal angle towards a longitudinal joint. Elements are to be installed horizontally. Their longitudinal joints are parallel, while the angle of both transversal joints is optional.

**DISCLAIMER**

All variations of Qbiss One non-orthogonal element are produced out of flat Qbiss One elements. Each corner is finalized outside robotized production train, therefore minor deviation in product tolerances, surface inconsistencies and local change in appearance might occur.

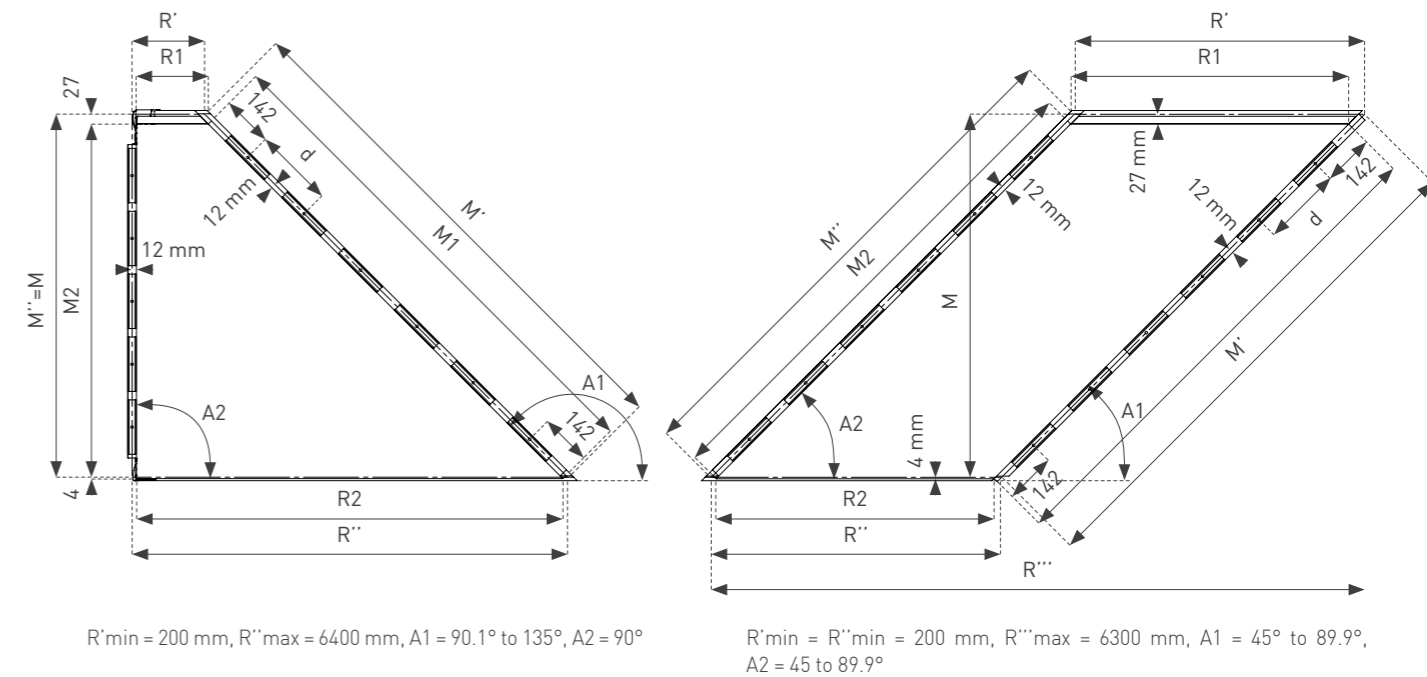

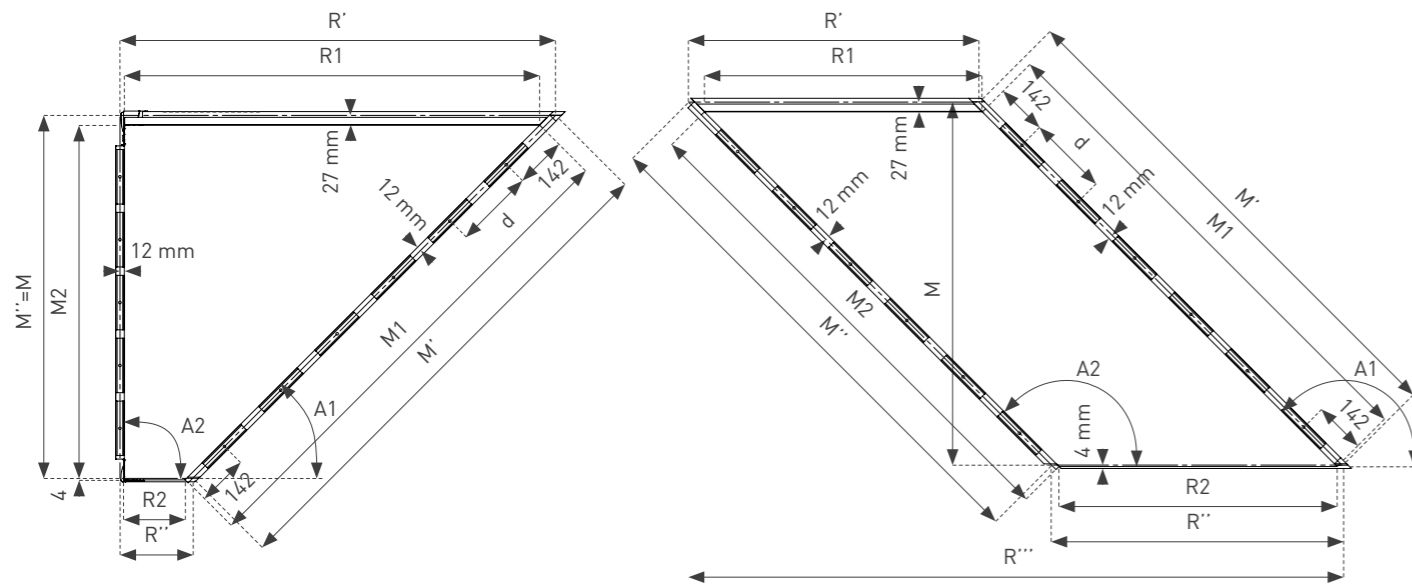

R'' min = 200 mm, R' max = 6400 mm, A1 = 45° to 89.9°, A2 = 90°

R' min = R'' min = 200 mm, R''' max = 6300 mm, A1 = 90.1° to 135°, A2 = 90.1 to 135°

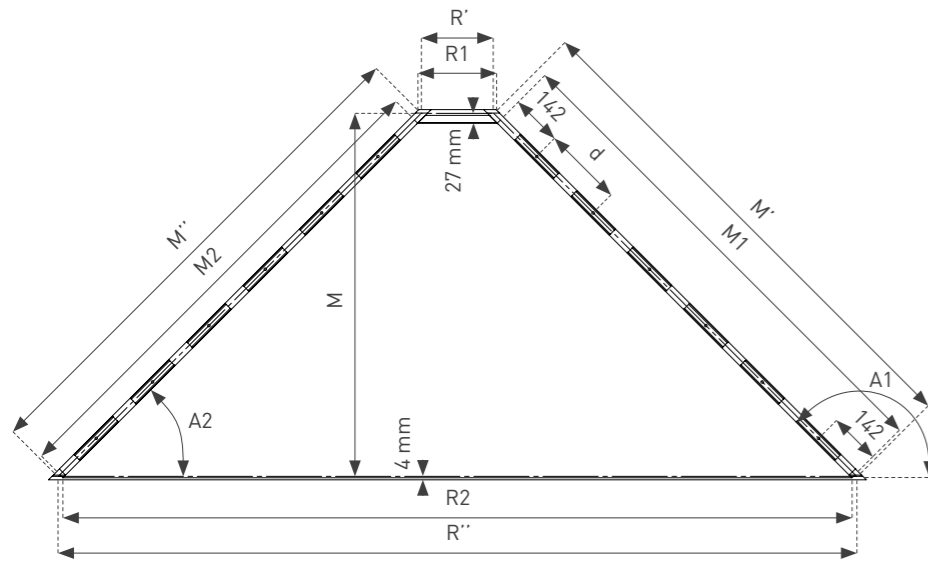

R' min = 200 mm, R'' max = 6300 mm, A1 = 90.1° to 135°, A2 = 45° to 89.9°

**DESIGN GUIDANCE AND PRODUCTION LIMITATION**

Design guidance	
Measure M1 / M2 according to designed element's flat edge angle and module width M.	
Choose max. number of fixing profiles according to table.	
Minimum angle A1 of inclined length M1: 45°. Always provide this angle input for ordering. Precision 0.1°.	
Maximum angle A1 of inclined length M1: 135°. Always provide this angle input for ordering. Precision 0.1°.	
Minimum angle A2 of inclined length M2: 45°. Always provide this angle input for ordering. Precision 0.1°.	
Maximum angle A2 of inclined length M2: 135°. Always provide this angle input for ordering. Precision 0.1°.	
Minimum centre from one fixing profile to another is 160 mm.	
Centre of first and last fixing profile is 142 mm from vertex of element's flat edges.	
Minimum number of fixing profiles is 2.	
Distribute fixing plate profiles equally by equation: $d = (M1 \text{ or } M2 - 284) / (N - 1)$ .	
Fixing profiles on A1 = 90° or A2 = 90° are distributed like on original Qbiss One element (142 mm from flat edge, max 5 fixing profiles).	
M	Module width of element. 600 to 1200 mm. Step: 1 mm.
M1	Length of inclined flat edge on side A1 (mm). Always provide this length input for ordering. Precision 0.1 mm.
M2	Length of inclined flat edge on side A2 (mm). Always provide this length input for ordering. Precision 0.1 mm.
R1	Length of flat edge on tongue longitudinal side [mm]. Always provide this length input for ordering. Precision 0.1 mm.
R2	Length of flat edge on groove longitudinal side (mm). Always provide this length input for ordering. Precision 0.1 mm.
M'	Length of centreline inside transversal joint on side A1 (mm). When A1 is 90°, M' is M. It lays 12 mm outside of flat edge.
M''	Length of centreline inside transversal joint on side A2 (mm). When A2 is 90°, M'' is M. It lays 12 mm outside of flat edge.
R'	Length of centreline inside longitudinal joint on tongue side (mm). It lays 27 mm outside of flat edge.
R''	Length of centreline inside longitudinal joint on groove side (mm). It lays 4 mm inside of flat edge.
R'''	Summed up horizontal length from one centreline intersection to other centreline intersection (mm).

Maximal number of fixing profiles	M1 and M2 (mm)
3	604 to 763
4	764 to 923
5	924 to 1083
6	1084 to 1243
7	1244 to 1664

**!** All applications and dimensions must be consulted and approved by Trimo technical support team.

# ARTME ON QBISS ONE

## ARTME

Artme is the latest, unique façade surface treatment that allows unlimited shapes, patterns and visual effects to be expressed on the Qbiss One for dramatic, individual and creative results. From designs and pictures to inscriptions, logos, brands and bespoke creations, ArtMe makes this possible without the need to use adhesives, additional elements or structural devices.

Suggest your own design or pick it out of our Artme pre-designs at:

[🌐 Artme technical guide](#)

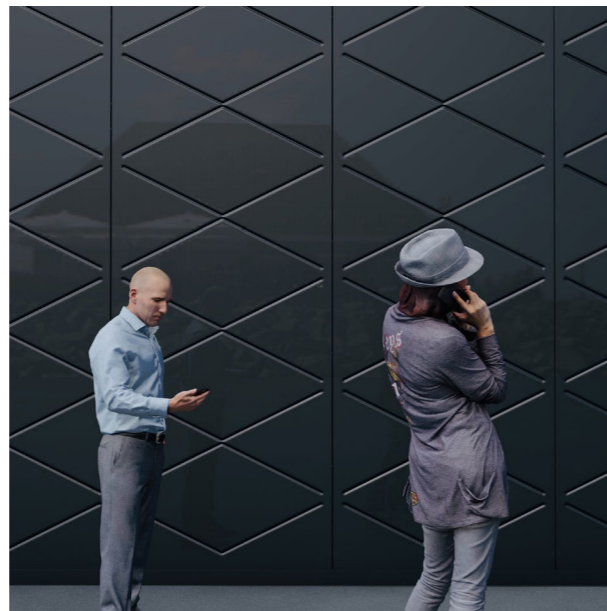

# INTERNAL WALL

## INTERNAL WALL SOLUTION

Trimo Qbiss One internal walls are vertical partitions used to separate building internal spaces and form internal rooms and circulation areas like corridors, passages, lobbies or evacuation routes. Amazing reaction to fire properties make Qbiss One element an excellent protection against fire.

Learn more about internal wall design at:

[🌐 CAD download centre](#)







## D. SYSTEM DESCRIPTION

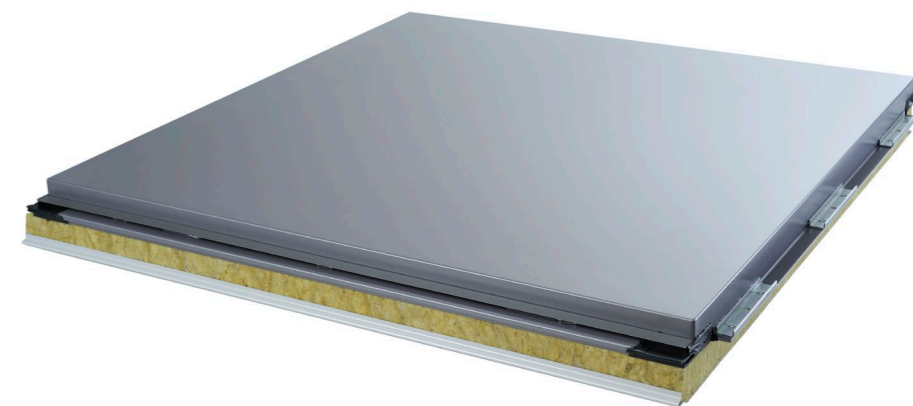

# SYSTEM COMPOSITION

## COMPLETE BUILDING ENVELOPE SYSTEM

Qbiss One brings a systems approach to the building envelope by uniting all the functional advantages of high quality façades with world-class design aesthetics. With all the elements prefabricated and manufactured by the latest automated technology, it delivers a long-term, sustainable building solution.

### Qbiss One B-B horizontal element joint detail



closed element corners

- 1 Sealing tape
- 2 EPDM corner gasket
- 3 Decorative Alu. extrusion HF40 and transversal gasket
- 4 Mastic seal
- 5 Fixing screw (wind-load fixing)
- 6 Load bearing fixing plate
- 7 Adjustable levelling substructure (optional)
- 8 Vertical load fixing screw (self-weight fixing)

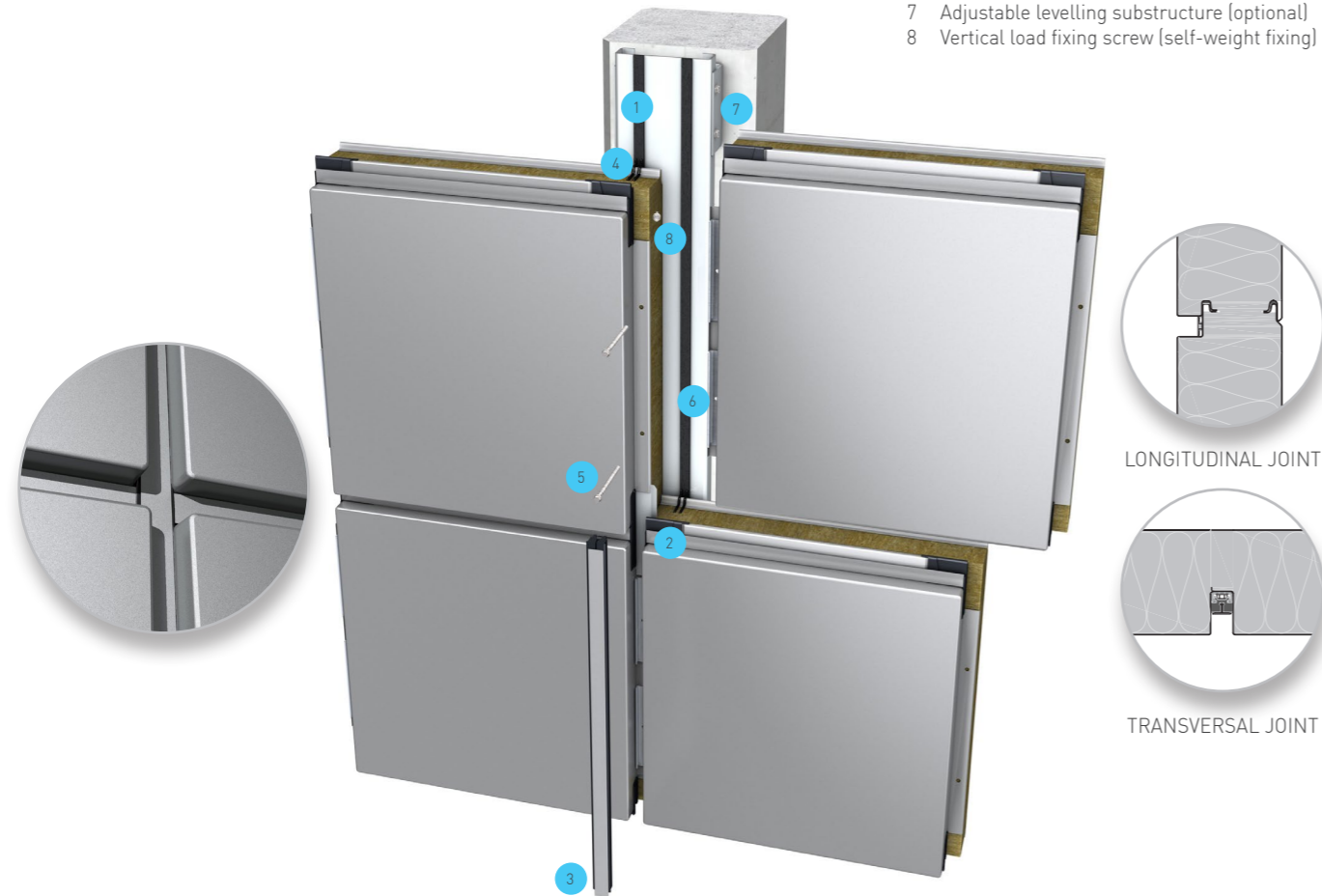

LONGITUDINAL JOINT

TRANSVERSAL JOINT

### COMPONENTS OF THE MODULAR FAÇADE SYSTEM

- Modular façade elements
- Fixing and sealing material
- Standard metal sheet flashing
- Joint interface detail for windows and doors
- Corner elements
- Fast fixing adjustable levelling substructure

## JOINT VARIATIONS

Qbiss One system allows various combinations of recessed and flush joints. It presents the ultimate combination of aesthetics, design and function. A playground for architects and a tool to show the world the excellence of design.

### Qbiss One F-B horizontal element joint detail



LONGITUDINAL JOINT F

TRANSVERSAL JOINT

### Qbiss One B-B vertical element joint detail



TRANSVERSAL JOINT

LONGITUDINAL JOINT

### INSTALLATION DIRECTION

Qbiss One elements can be distinguished based on elements installation methods. Methods depend on the direction of installation.

Qbiss One horizontally and vertically laid element

R – Design length  
M – Module width

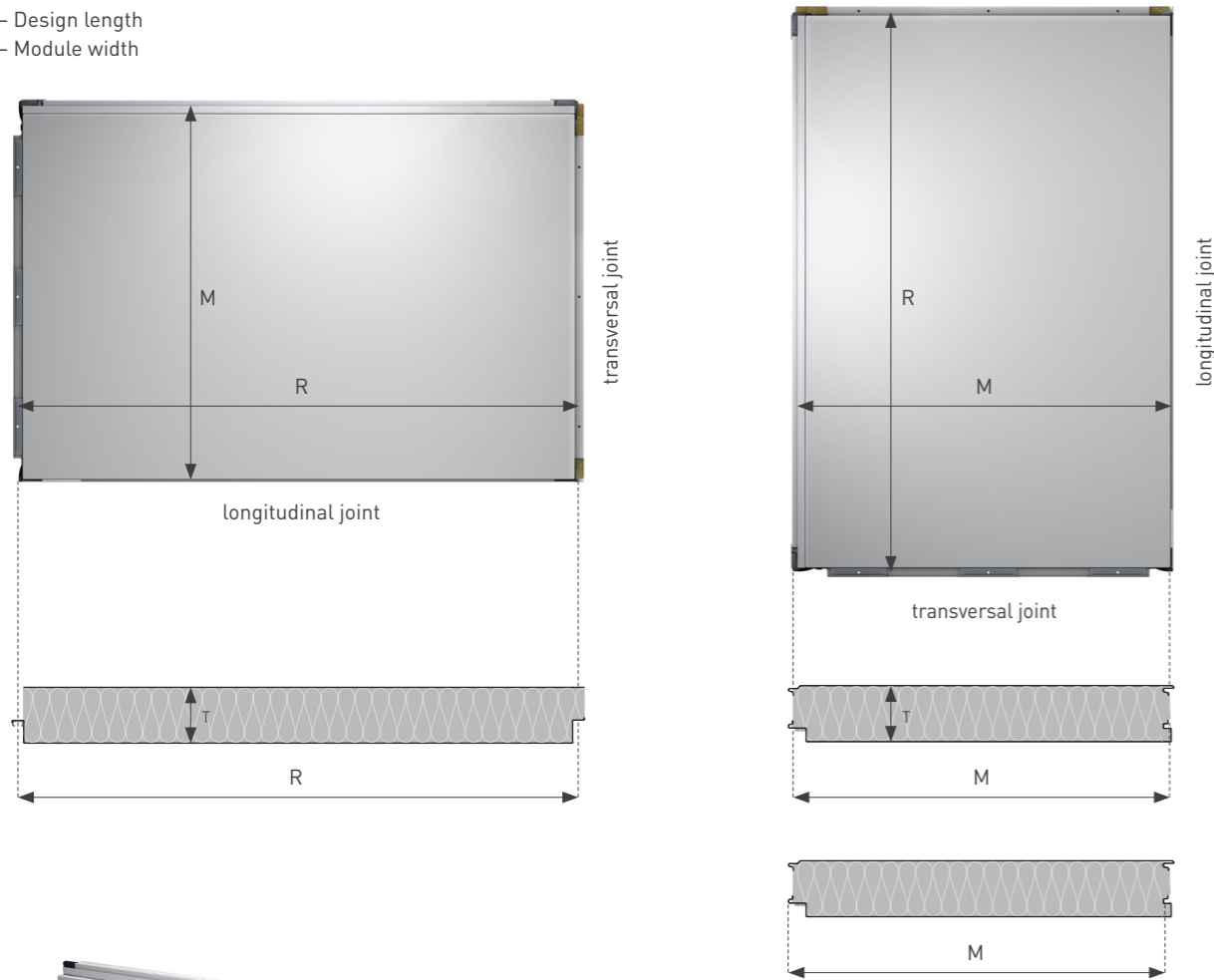

Qbiss One element finishing / based on element types

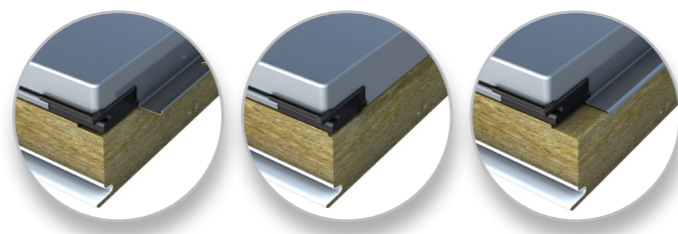

Qbiss One element types

Element type	Element finishing scheme	Element format	Installation direction	Installation method
1		BOTH - SIDED	LEFT - RIGHT	HORIZONTAL, VERTICAL, HORIZONTAL BRICK, HORIZONTAL ASYMMETRICAL BRICK, VERTICAL BRICK
2		BOTH - SIDED	RIGHT - LEFT	HORIZONTAL, HORIZONTAL BRICK, HORIZONTAL ASYMMETRICAL BRICK
3		BOTH - SIDED	INITIAL (FIRST)	HORIZONTAL, VERTICAL, HORIZONTAL BRICK, HORIZONTAL ASYMMETRICAL BRICK, VERTICAL BRICK
4		BOTH - SIDED	TERMINAL (LAST)	HORIZONTAL, HORIZONTAL BRICK, HORIZONTAL ASYMMETRICAL BRICK
5*		RIGHT	INITIAL (FIRST)	HORIZONTAL, VERTICAL, HORIZONTAL BRICK, HORIZONTAL ASYMMETRICAL BRICK, VERTICAL BRICK
6*		RIGHT	TERMINAL (LAST)	HORIZONTAL, HORIZONTAL BRICK, HORIZONTAL ASYMMETRICAL BRICK
7*		LEFT	INITIAL (FIRST)	HORIZONTAL, VERTICAL, HORIZONTAL BRICK, HORIZONTAL ASYMMETRICAL BRICK
8*		LEFT	TERMINAL (LAST)	HORIZONTAL, VERTICAL, HORIZONTAL BRICK, HORIZONTAL ASYMMETRICAL BRICK, VERTICAL BRICK
9*		NONE	INITIAL (FIRST) TERMINAL (LAST) LEFT - RIGHT RIGHT - LEFT	HORIZONTAL, VERTICAL, HORIZONTAL BRICK, HORIZONTAL ASYMMETRICAL BRICK
10*		BOTH - SIDED	LEFT - RIGHT RIGHT - LEFT	HORIZONTAL FAÇADE RADIUS REQUIRED
11*		RIGHT	LEFT - RIGHT RIGHT - LEFT	HORIZONTAL FAÇADE RADIUS REQUIRED
12*		LEFT	LEFT - RIGHT RIGHT - LEFT	HORIZONTAL FAÇADE RADIUS REQUIRED

\* The minimum Qbiss One length is set to 550 mm. The maximum Qbiss One length is set to 6475 mm. 550 mm < R < 6475 mm

The installation is initiated using a Qbiss One corner element at the extreme axis of the building, however, the adjacent Qbiss One façade element can be installed if the corner elements have not been delivered yet.

The project usually contains installation direction for each face of the building separately. If this is not prescribed in the project, the standard installation direction is from the left to the right.

**INSTALLATION RECOMMENDATIONS**

Regardless of installation direction, the first row on the main profile should be constructed and all the other rows should be installed as “pyramidal” system, presented below.

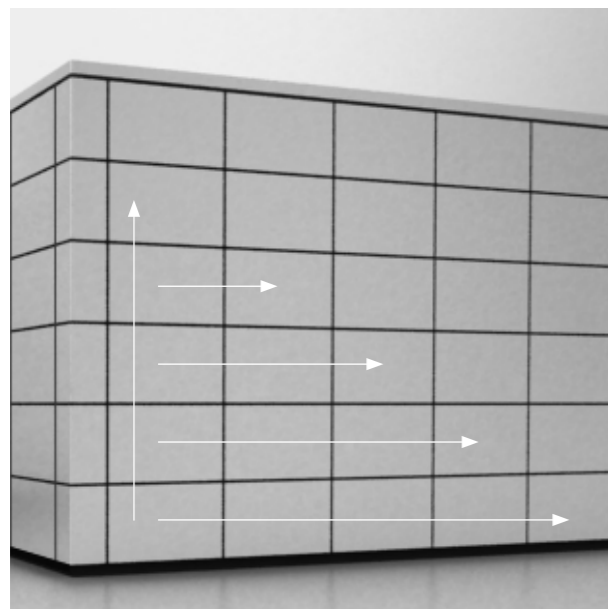

Installation direction from the left to the right.

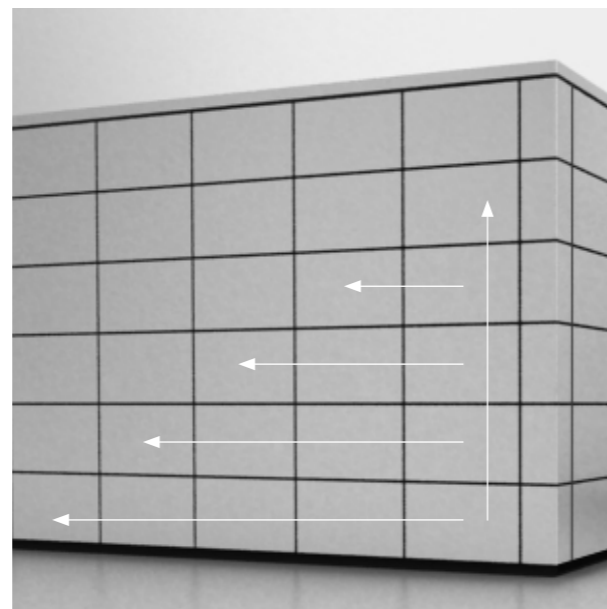

Installation direction from the right to the left.

TYPES OF LOAD BEARING STRUCTURES

Classic steel structure is suitable for installing Qbiss One façade elements, when required tolerances are met. If the main structure does not meet the tolerances, an adjustable levelling substructure must be used.

The installation system depends on the type of main structure:

- Qbiss One façade elements are fixed
  - Directly onto steel structures (if the main structure is within permissible tolerances).
  - If the main structure is not within the permissible tolerances a levelling substructure must be used.
- Two methods of fixing are used for concrete structures
  - Using adjustable levelling substructures,
  - Using a wide levelling profile.



[🔗 Link to permissible deviations chapter](#)

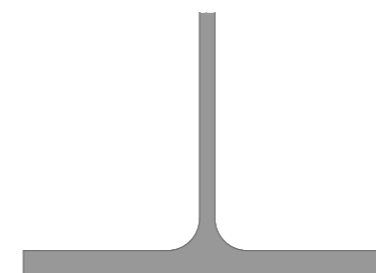

Steel structure within permissible tolerances

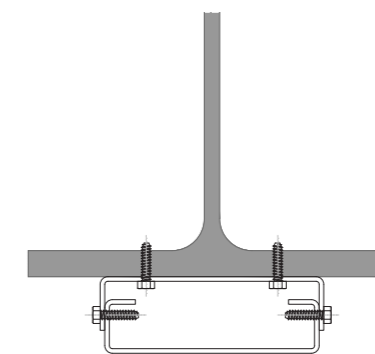

Steel with fast adjustable levelling substructure

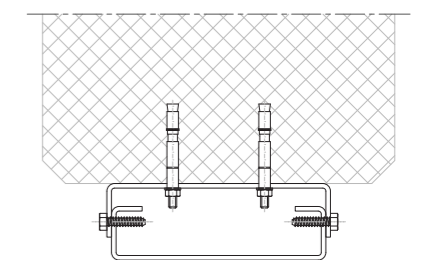

Concrete structure with fast adjustable levelling substructure

! The minimum required contact surface of Qbiss One modular façade system is given by static calculations for each separate project. A levelling substructure must be used when main structure is not within permissible tolerances.

## D. SYSTEM DESCRIPTION

# LEVELLING SUBSTRUCTURE

### FAST ADJUSTABLE LEVELLING SYSTEM

Fast adjustable levelling substructure (FALS), a quick mounting system is suitable for the use on uneven concrete or steel structures to achieve finished level surface without additional welding or adding material to support structure.

#### PREPARATION

Preparation of a suitable structure or substructure in accordance with the provisions of these instructions is required to ensure quality, tightness, and durability of the façade system.

If the structure fails to meet permissible tolerances, fast adjustable levelling structure system (Fast-Adjustable-Leveling-Substructure) must be used.

#### MINIMUM SUPPORT WIDTHS

The minimum required contact surface of the Qbiss One modular façade system is provided by structural analysis for each separate project. In cases when there is no calculation, the minimum width of the contact surface is ( $b_{min}$ ) is 50 mm per edge of façade element.



- 1 Support frames - wide are fixed to the structure using certified anchor screws.
- 2 The contact surface profile that defines the level of façade elements is fixed onto the prepared line of profiles using self-tapping screws.

**FAST ADJUSTABLE LEVELLING SUBSTRUCTURE RANGE**

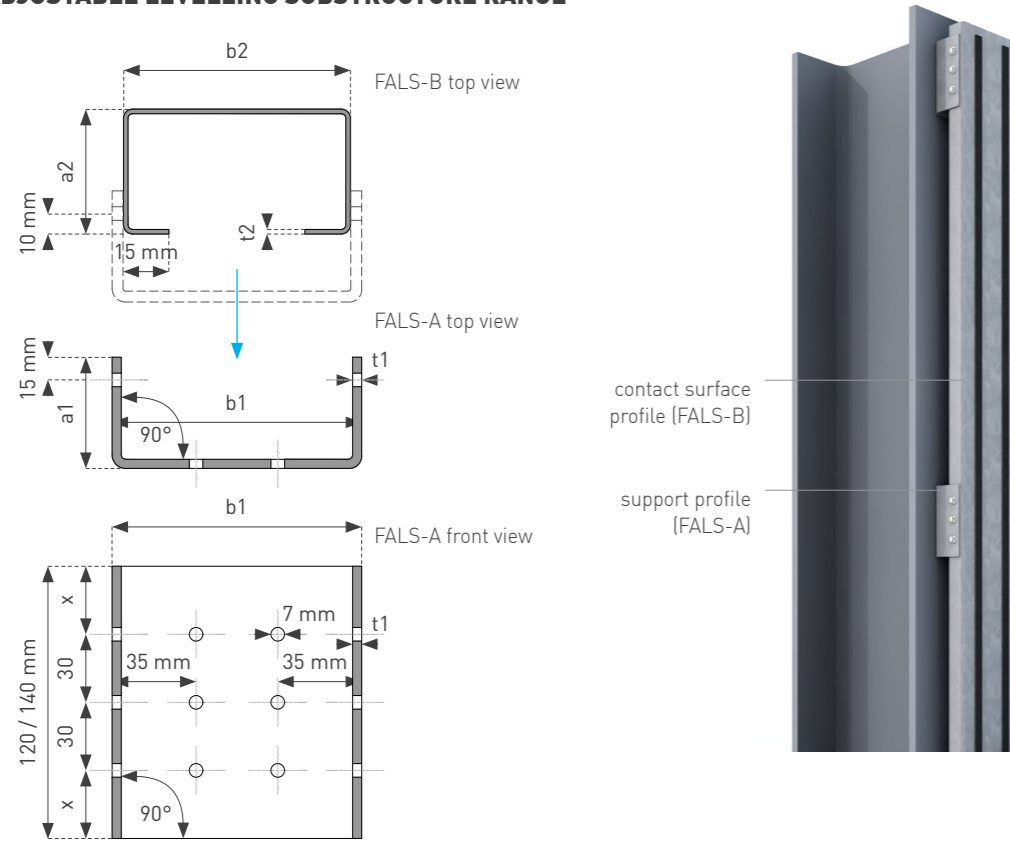

FALS-B	
Name	B55-2/120      B65-2/120
Height (a2)	55 mm      65 mm
Width (b2)	120 mm      120 mm
Thickness (t2)	2 mm      2 mm
Length	4000 mm      4000 mm
Marking	C-15/55/120/55/15/2      C-15/65/120/65/15/2

FALS-A								
Name	120/A55-4-L120	120/A55-5-L120	120/A55-4-L140	120/A55-5-L140	120/A75-4-L120	120/A75-5-L120	120/A75-4-L140	120/A75-5-L140
Height (a1)	55 mm	55 mm	55 mm	55 mm	75 mm	75 mm	75 mm	75 mm
Width (b1)	129 mm	131 mm	129 mm	131 mm	129 mm	131 mm	129 mm	131 mm
Thickness (t1)	4 mm	5 mm	4 mm	5 mm	4 mm	5 mm	4 mm	5 mm
Length	120 mm	120 mm	140 mm	140 mm	120 mm	120 mm	140 mm	140 mm
x	30 mm	30 mm	40 mm	40 mm	30 mm	30 mm	40 mm	40 mm

OFFSET FROM BASE STRUCTURE	
Neutral position	70 mm      90 mm
Minimal offset	60 mm      75 mm
Maximal offset	85 mm      115 mm

Profile FALS-A	120/A55-4-L120	120/A55-4-L140	120/A55-5-L120	120/A55-5-L140
Wind load w' (kN/m')	0 - 2,41	0 - 3,09	0 - 4,09	0 - 4,96

Profile FALS-A	120/A75-4-L120	120/A75-4-L140	120/A75-5-L120	120/A75-5-L140
Wind load w' (kN/m')	0 - 1,93	0 - 2,63	0 - 3,56	0 - 4,55

Permissible wind loads on the FALS-A profile (for elements with the weight of  $g' < 1,50 \text{ kN/m}^2$ ).

Profile FALS-A	120/A55-4-L120	120/A55-4-L140	120/A55-5-L120	120/A55-5-L140
Wind load w' (kN/m')	0 - 2,10	0 - 2,80	0 - 3,74	0 - 4,67

Profile FALS-A	120/A75-4-L120	120/A75-4-L140	120/A75-5-L120	120/A75-5-L140
Wind load w' (kN/m')	0 - 1,41	0 - 2,22	0 - 3,04	0 - 4,09

Permissible wind loads on the FALS-A profile (for elements with the weight of  $1,50 < g' \leq 2,10 \text{ kN/m}^2$ ).

**Example 1**

Element: Qbiss One  
 Thickness: 150 mm  
 Core: Power T  
 External / Internal steel sheet thickness: 0,7 / 0,55  
 $g = 0,251 \text{ kN/m}^2$  (see page B3.1)  
 $w = 0,7 \text{ kN/m}^2$   
 $A = 4 \text{ m}$   
 Height of profile FALS-A: 75 mm

Calculation:  
 Step 1; Loads on vertical FALS-B profiles  
 $g' = g \times A = 0,251 \text{ kN/m}^2 \times 4 \text{ m} = 1,004 \text{ kN/m}'$   
 $w' = w \times A = 0,7 \text{ kN/m}^2 \times 4 \text{ m} = 2,8 \text{ kN/m}'$   
 Step 2; Select FALS-A considering  $g'$   
 $g' = 1,004 \text{ kN/m}' < 1,5 \text{ kN/m}' \rightarrow \text{FALS-A } 120/\text{A75-5-L120}$   
 Step 3; Select FALS-B (see the table on page D1.9)  
 FALS-A = 120/A75-5-L120  $\rightarrow$  FALS-B = B65-2/120

**Example 2**

Element: Qbiss One  
 Thickness: 200 mm  
 Core: Power S  
 External / Internal steel sheet thickness: 0,7 / 0,55  
 $g = 0,343 \text{ kN/m}^2$  (see page B3.1)  
 $w = 0,8 \text{ kN/m}^2$   
 $A = 5 \text{ m}$   
 Height of profile FALS-A: 55 mm

Calculation:  
 Step 1;  $g' = 0,343 \text{ kN/m}^2 \times 5 \text{ m} = 1,715 \text{ kN/m}'$   
 $w' = 0,8 \text{ kN/m}^2 \times 5 \text{ m} = 4 \text{ kN/m}'$   
 Step 2; FALS-A = 120/A55-5-L140  
 Step 3; FALS-B = B55-2/120

Loads on vertical FALS-B profiles  
 $g'$  -  $g \times A$  (kN/m')  
 $w'$  -  $w \times A$  (kN/m')

$w$  - wind suction (kN/m<sup>2</sup>)  
 $A$  - raster of vertical profiles FALS-B (m)  
 $g$  - weight of the element; see page B3.1 (kN/m<sup>2</sup>)



### INSTALLATION AND CONTROL

Fast adjustable levelling substructure (FALS), a quick mounting system is suitable for uneven concrete or steel structures. The main purpose of fast adjustable levelling substructure is to ensure the level of the final surface and to reduce the time spent for installing of the substructure as well as the façade systems.

#### HORIZONTAL SET-OUT

Measure from origin.  
Main structure check

1. grid and overall actual dimension A
2. grid and overall design dimension D

Difference on main structure  
 $\Delta AD = AD$  shall be smaller than LDC.

Find best fit of Levelling substructure

1. Levelling Design Compensation LDC
2. Levelling Actual Compensation  $LAC = LDC - \Delta DA$

Set-out gridlines and mark them on the building.

Install levelling substructure according to set gridlines.  
Assure vertical and LAC.

Install façade elements according to set gridlines and consider installation tolerances.

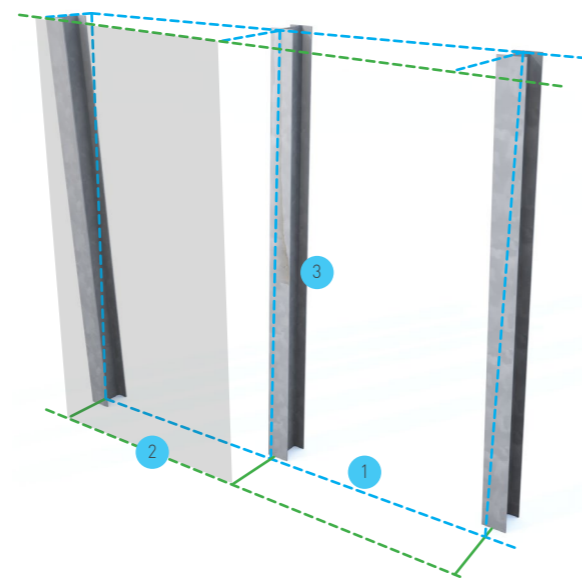

- 1 Overall design dimension
- 2 Overall levelling dimension
- 3 Overall actual dimension

#### VERTICAL SET-OUT

Measure from set horizontal reference.  
Main structure check

1. grid and overall actual dimension A
2. grid and overall design dimension D

Difference on main structure  
 $\Delta AD = AD$  shall be smaller than LDC.

Find best fit of Levelling substructure

1. Levelling Design Compensation LDC
2. Levelling Actual Compensation  $LAC = LDC - \Delta DA$

Set-out gridlines and mark them on the building.

Install levelling substructure according to set gridlines.  
Assure vertical and LAC.

Install façade elements according to set gridlines and consider installation tolerances.

#### 3D DETAIL

FALS allows installation of façade elements in a horizontal direction. It is suitable for full concrete walls as well as concrete and steel skeletal structures.

- 1 Reinforced concrete support
- 2 Fixing screw
- 3 Support profile
- 4 Sealing tape 5x10
- 5 Contact surface profile

🌐 CAD download centre

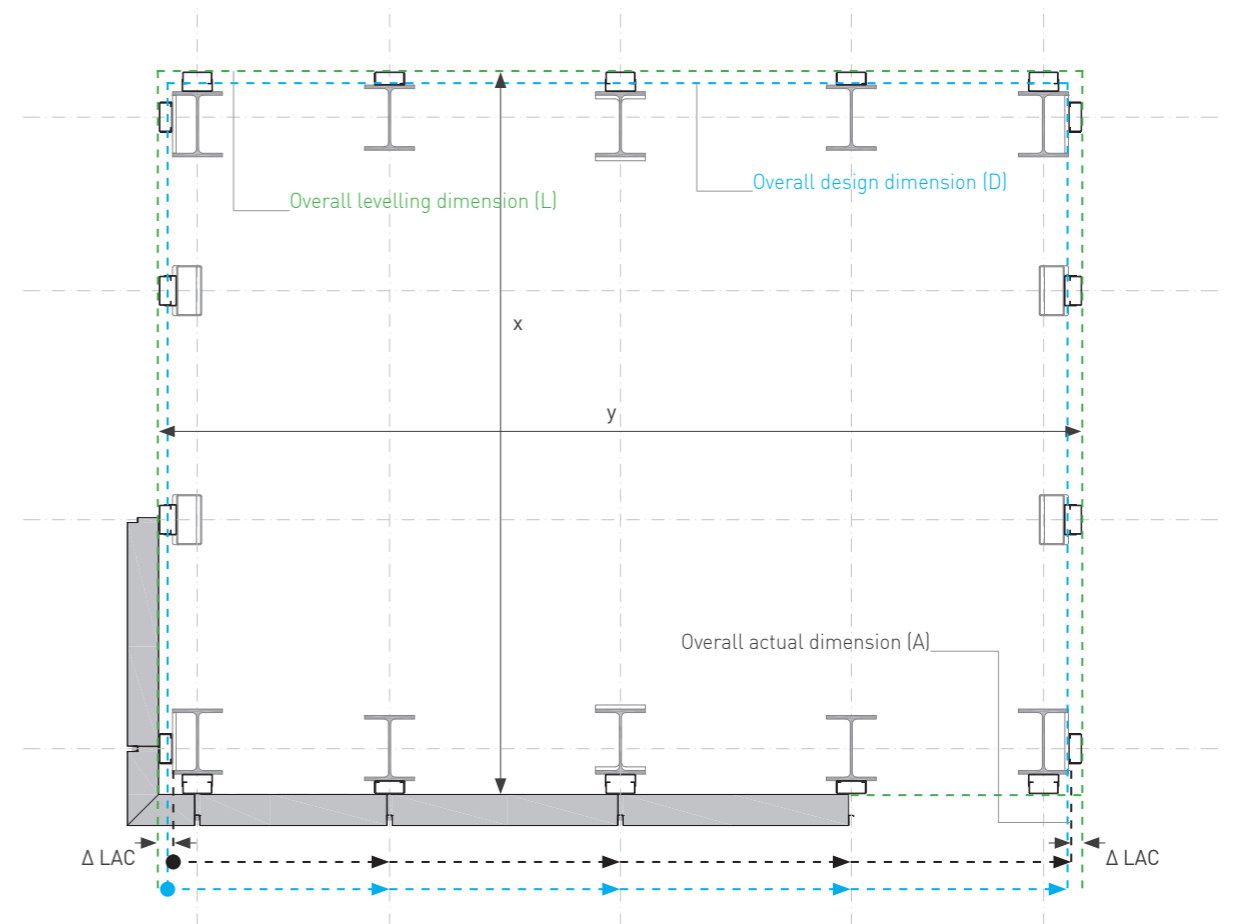
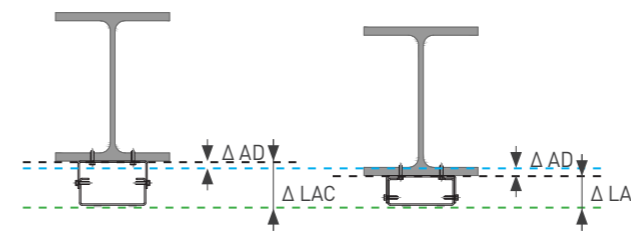
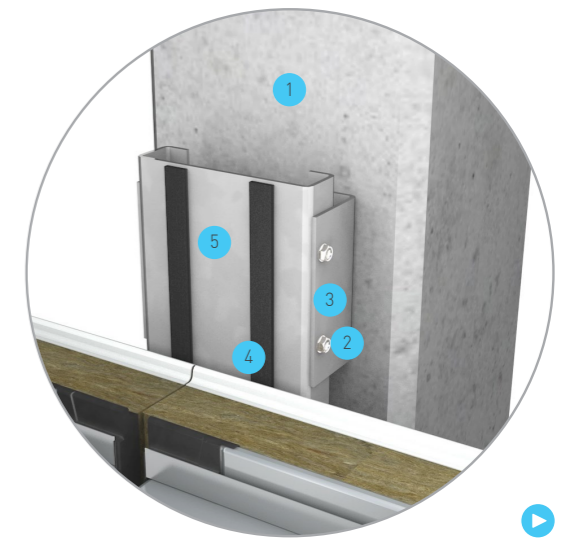

# INSTALLATION METHODS

## VARIOUS INSTALLATION METHODS

To give architects possibility to express their style by choosing Qbiss One façade elements / system, we developed elements, that can be installed in various possible ways.

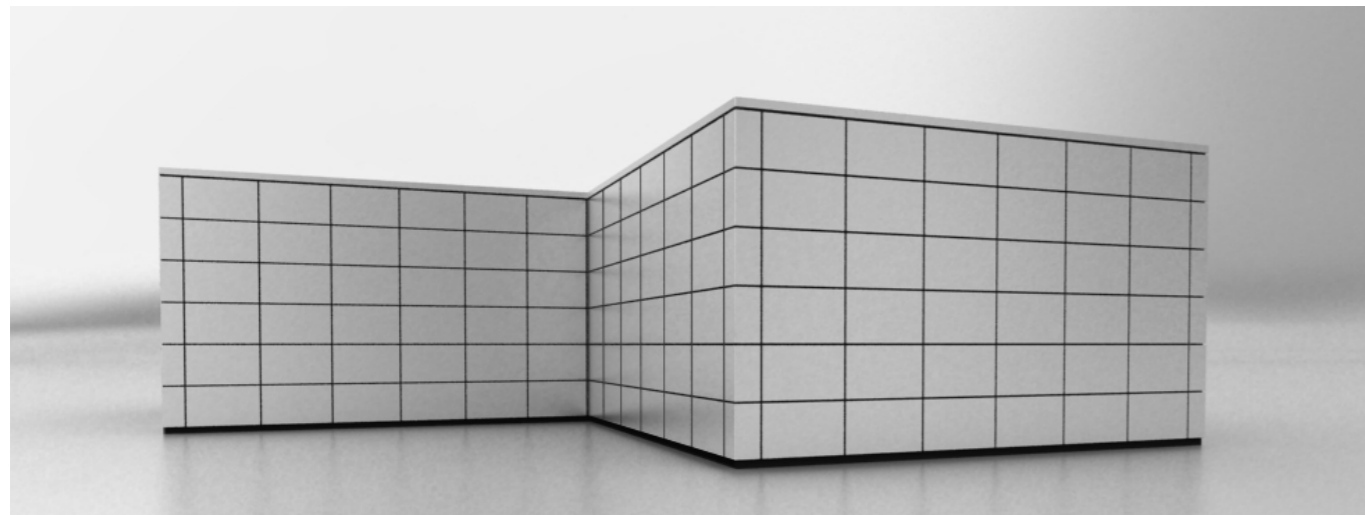

HORIZONTAL

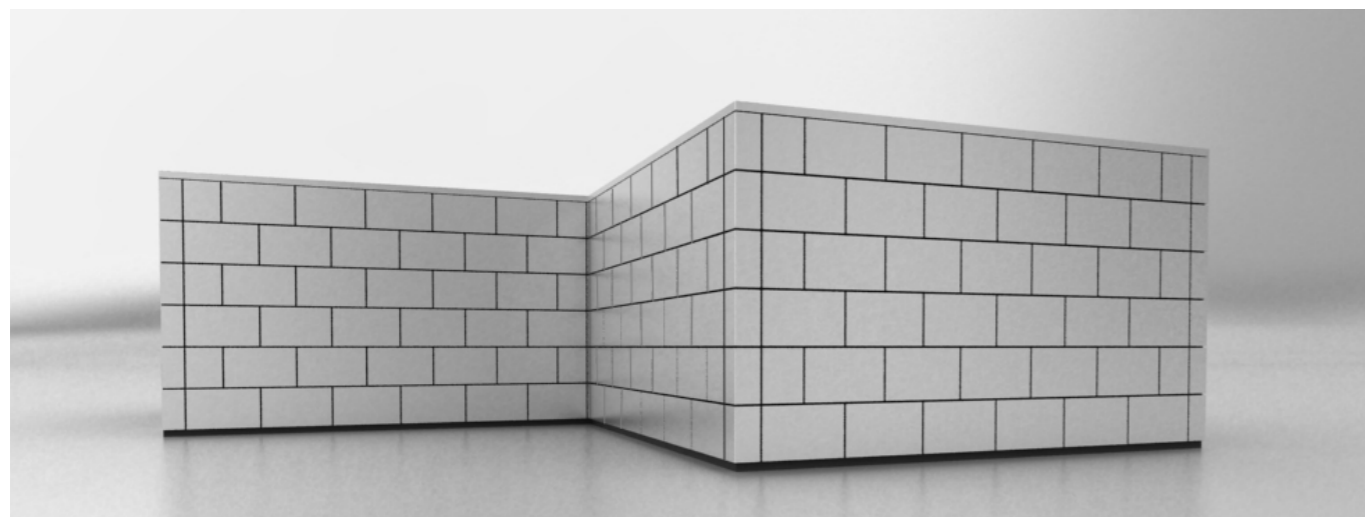

BRICK HORIZONTAL

! In case of Qbiss One brick installation, the amount of substructure will increase.

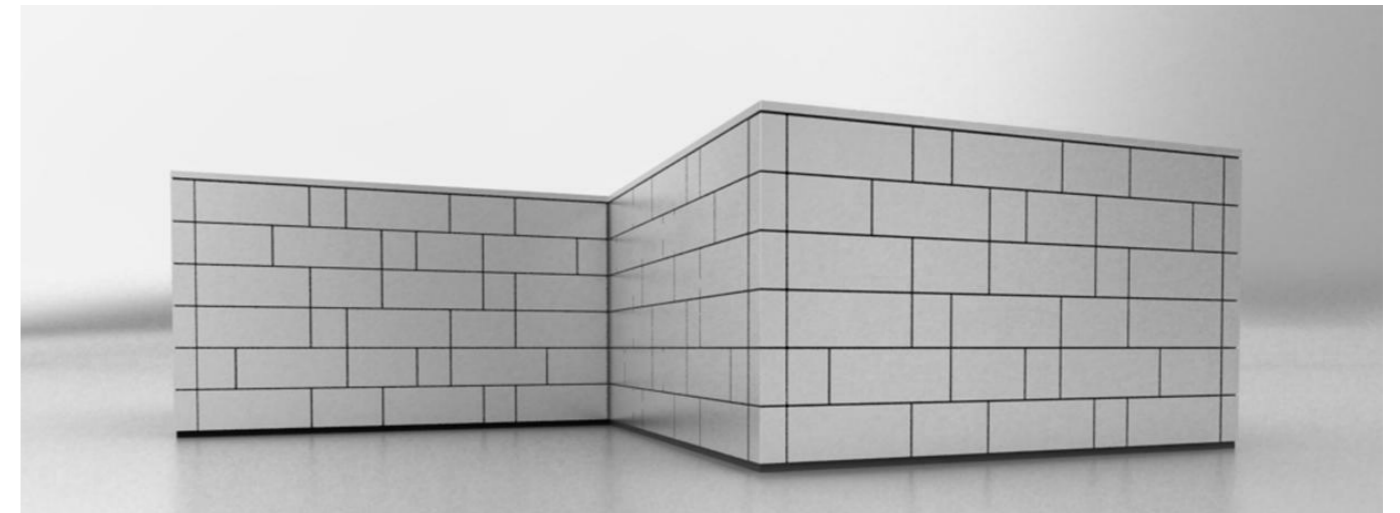

ASYMMETRICAL HORIZONTAL

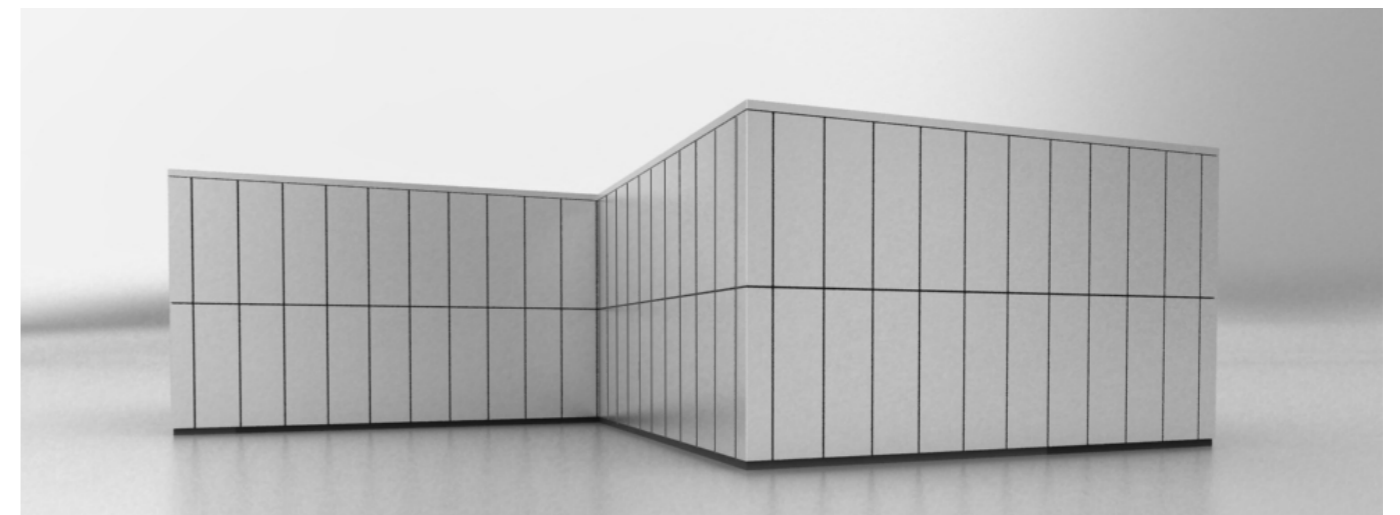

VERTICAL

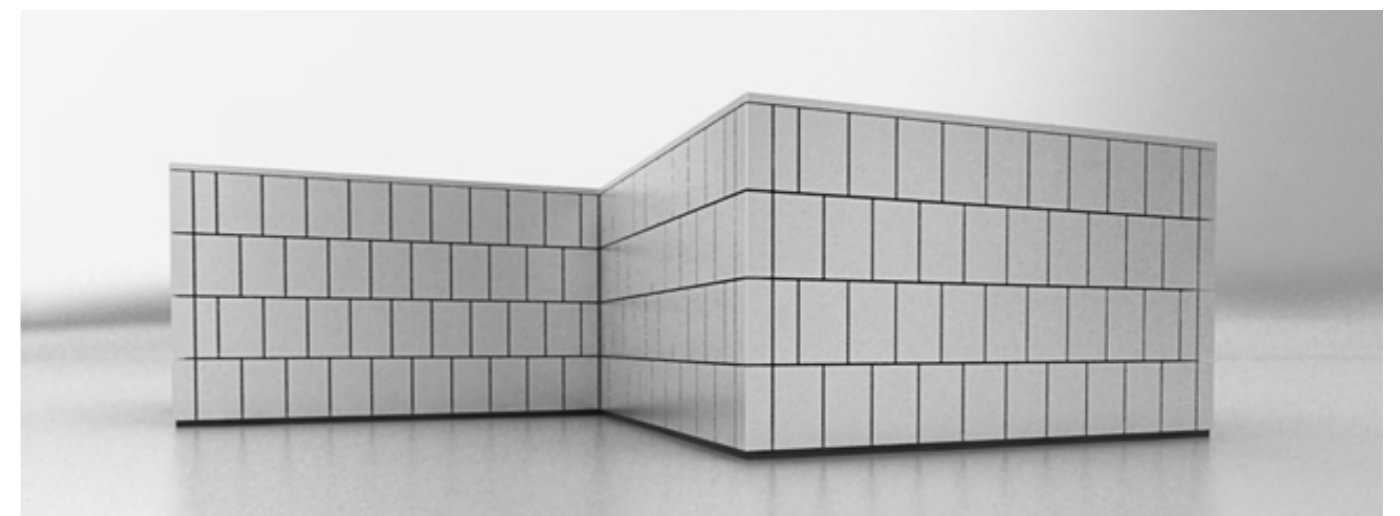

BRICK VERTICAL



🏠 D. SYSTEM DESCRIPTION  
**JOINT OPTIONS**

Qbiss One delivers the greatest freedom of expression. It enables you to create a unique aesthetic of the building by using different types of joints between elements. A playground for architects and a tool to show the world the excellence of design. Discover all possibilities with:

- joint option for vertical installation
- joint option for horizontal installation

**LONGITUDINAL JOINT**

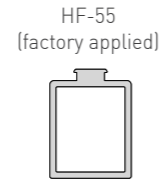

**TRANSVERSAL JOINT**

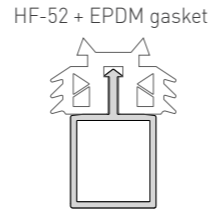
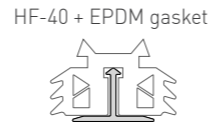

**QBISS ONE VERTICAL ELEMENT JOINT OPTIONS**

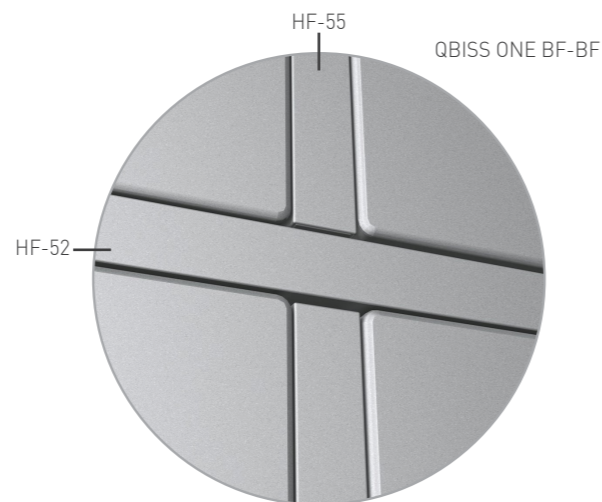
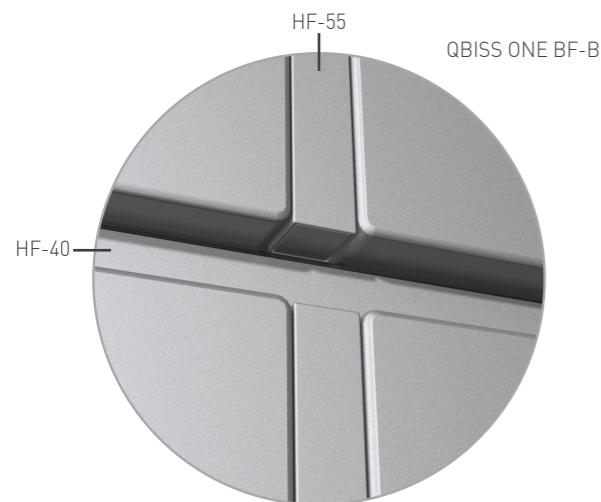
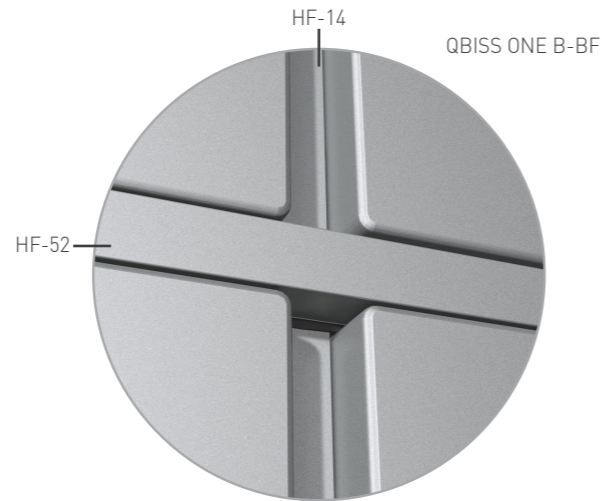
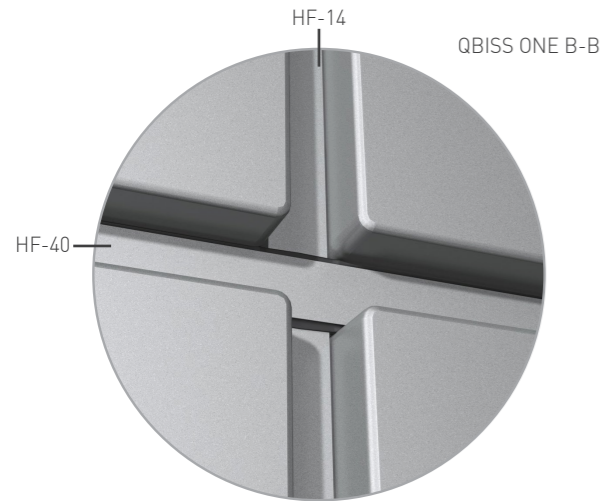

D. SYSTEM DESCRIPTION



**QBISS ONE HORIZONTAL ELEMENT JOINT OPTIONS**

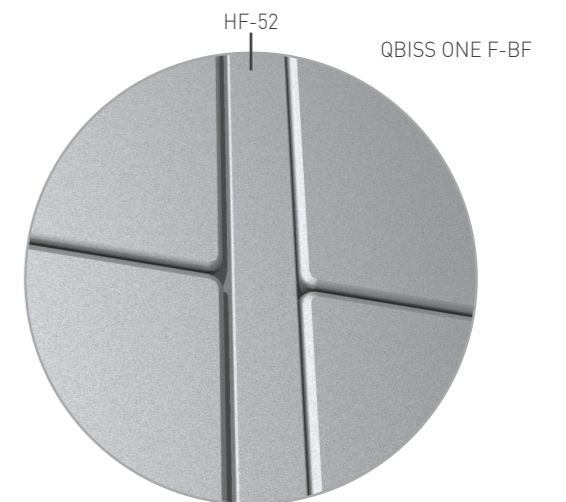
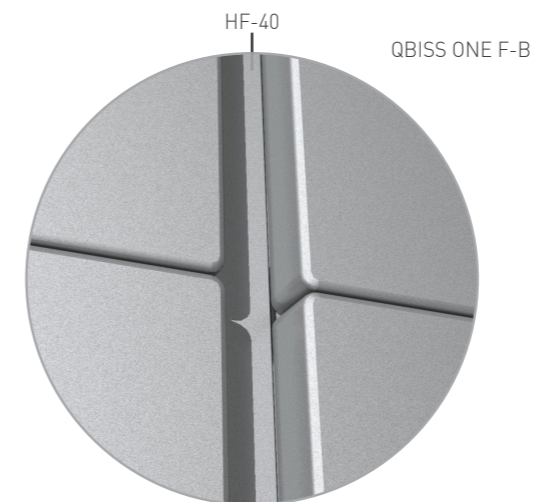
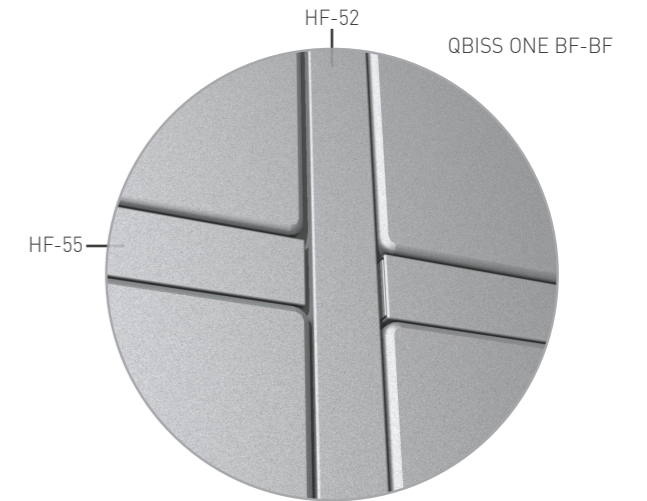
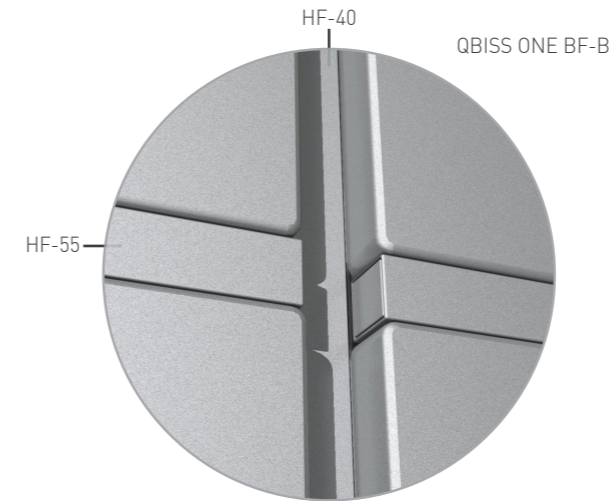
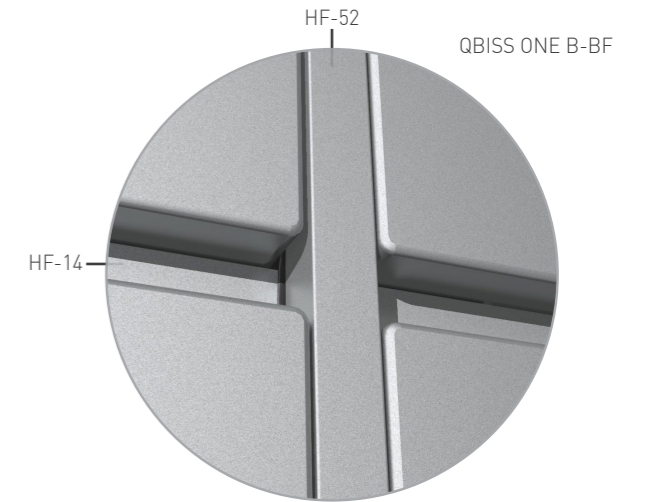
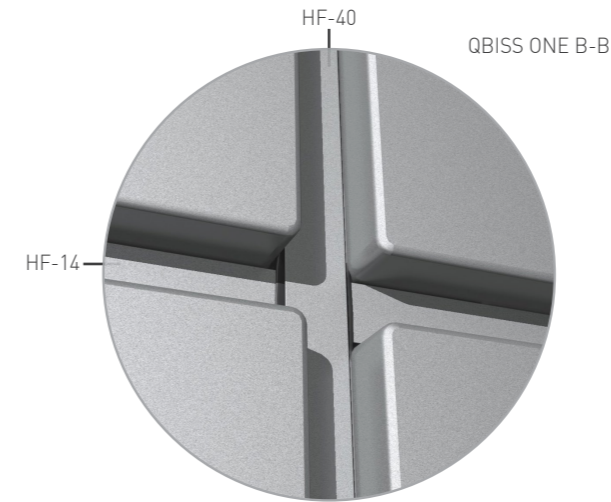

# SELECTION OF FIXING & METHODS

## SELECTION OF FIXINGS

Qbiss One façade elements are fixed structure with two types of screws through the internal and external metal sheet. Each element has pre-fabricated bores (fixing points) on the points of fixation. The required number of screws is defined by structural analysis for the project. Only certified fixing material (ETA, DoP) can be used.

Fixation through the internal metal sheet is carried out with special screws for fixation of thin metal sheets.

THICKNESS OF THE ELEMENT (mm)	SELF-TAPPING SCREW (A2)	SELF-DRILLING SCREWS (A2)
applies to all thicknesses	6.3 x 25	5.5 x 32/5.5 x 38

Display of fixing through internal and external metal sheet.



Type of screw for fixation through internal sheet metal and a drill bit.

SUBSTRUCTURE THICKNESS FOR SCREW Ø 6.3 mm	NOMINAL FIXING DIAMETER (mm)
2.0 - 3.0 (type A)	5.00
3.0 - 3.9	5.05
4.0 - 4.9	5.35
5.0 - 5.9	5.65
6.0 - 10.0	5.80
> 10.0	5.85

Fixing through the internal metal sheet:

- 1a: element thickness up to 100 mm one screw is required
- 1b: element thickness from 100 mm and above two screws are required.

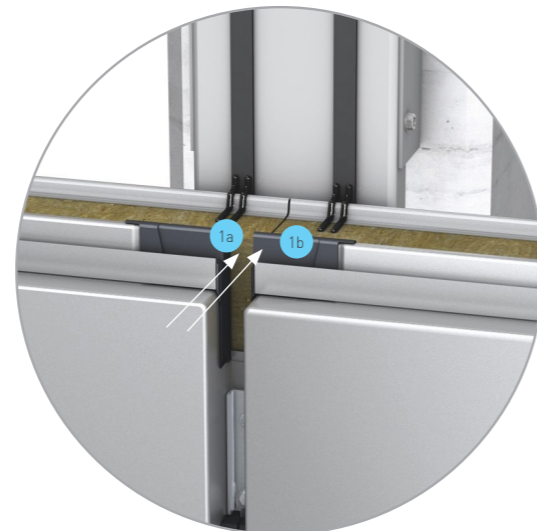

**!** For fixing using external sheet metal, screws without washers are used (at the point of fixing plate).

Qbiss One façade elements are fixed with self-tapping screws.

ELEMENT THICKNESS (mm)	SELF-TAPPING SCREW (A2) WITHOUT WASHER	SELF-TAPPING SCREW (A2) WITH WASHER	FIXING LENGTH
	FIXATION IN TRANSVERSAL JOINT - SCREW LENGTH (mm)	FIXATION THROUGH THE ELEMENT - SCREW LENGTH (mm)	MINIMUM LENGTH (mm)
80	51	115	100
100	76	127	120
120	100	152	140
133	115	152	155
150	127	178	170
172	152	200	200
200	178	265	220
240	215	265	260
250	265	285	270

Required minimum lengths of self-tapping screws for thickness of sub-construction (max. 10 mm). Check with fixings suppliers.

## 🏠 D. SYSTEM DESCRIPTION

Qbiss One façade elements can also be fixed with self-drilling screws.

ELEMENT THICKNESS (mm)	SELF-DRILLING SCREWS (A2) WITHOUT WASHERS		SELF-DRILLING SCREWS (A2) WITH WASHERS	
	FIXATION IN TRANSVERSAL JOINT - SCREW LENGTH (mm)		FIXATION THROUGH THE ELEMENT - SCREW LENGTH (mm)	
	SUBSTRUCTURE THICKNESS UP TO 5 mm	SUBSTRUCTURE THICKNESS BETWEEN 4 AND 14 mm	SUBSTRUCTURE THICKNESS UP TO 5 mm	SUBSTRUCTURE THICKNESS BETWEEN 4 AND 14 mm
80	62	71	113	118
100	92	99	133	147
120	113	118	163	168
133	133	138	163	168
150	163	168	193	193
172	193	218	193	218
200	193	193	236	243
240	236	243	280	280
250	261	268	286	293

Required minimum lengths of self-drilling screws.  
Check with fixings suppliers.



CENTRUM RIVIERA GDYNIA  
POLAND

VERTICAL QBISS ONE

2013  
VALODE AND PISTRE ARCHITECTES,  
MATEUSZ TAŃSKI & ASSOCIATES,  
MICHAŁEWICZ & CO.

**SCREWS TIGHTENING IN ELEMENT JOINT**

Pre-drilling is required when self-tapping screws are used. Swarfs created by the drilling have to be completely removed from Qbiss One elements and other paint coated steel skin immediately after the fixation of screws, otherwise they may cause surface corrosion.

Levelling of surface is ensured by tightening the screw. If necessary the screw can be loosened. Using torque limiter on the screwdriver is not allowed.

**SCREW LENGTH DEFINITIONS**

- $L_{min\ screw} = A+B$
- $A = Qbiss\ One\ element\ thickness\ (T) - 45\ mm$
- $B = thickness\ of\ substructure + 2\ x\ pitch + screw\ tip$

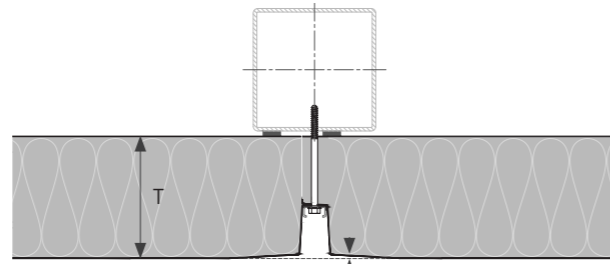

Consequence of excessively tightened screw.

- $L_{min\ screw} = A+B$
- $A = Qbiss\ One\ element\ thickness\ (T) - 45\ mm$
- $B = thickness\ of\ substructure + 2\ x\ pitch$

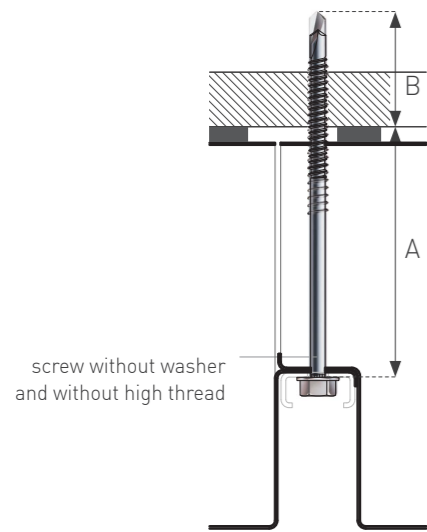

The right screw length in case of using a self-drilling screw.

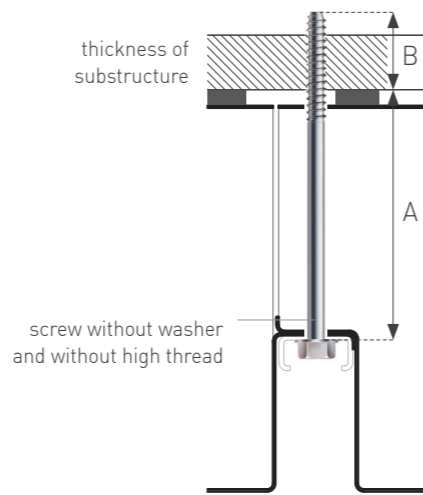

The right screw length in case of using a self-tapping screw.

! Do not overtighten the screws as local deformation in the external steel sheet of Qbiss One façade elements may occur. Only intact screws without washers and without thread under the screw head may be used.

Screw lengths are based on particular screw supplier. Please check with your own supplier required lengths on the base of exact design case. It's a designer's responsibility to use proper screws.

- $L_{min\ screw} = A+B$
- $A = Qbiss\ One\ element\ thickness\ (T) - 25\ mm$
- $B = thickness\ of\ substructure + 2\ x\ pitch$

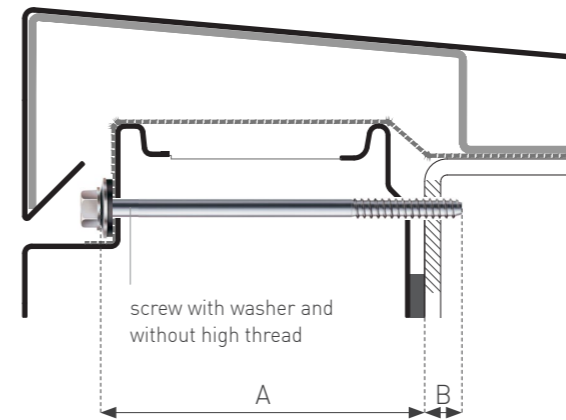

The right screw length for attachment in longitudinal joint of Qbiss One parapet wall in case of using a self-tapping screw.

- $L_{min\ screw} = A+B$
- $A = Qbiss\ One\ element\ thickness\ (T) - 25\ mm$
- $B = thickness\ of\ substructure + 2\ x\ pitch + screw\ tip$

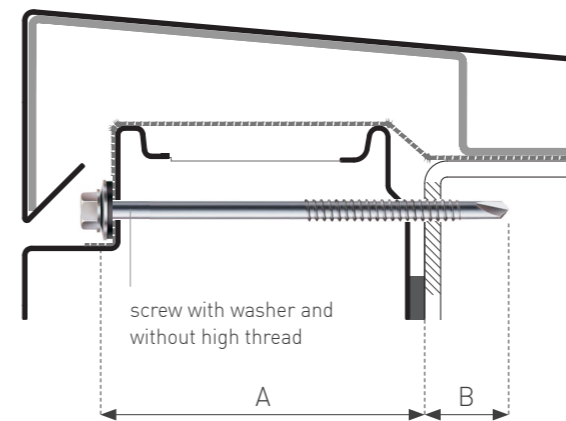

The right screw length for attachment in longitudinal joint of Qbiss One parapet wall in case of using a self-drilling screw.

- $L_{min\ screw} = A+B$
- $A = Qbiss\ One\ element\ thickness\ (T) + 5\ mm$
- $B = thickness\ of\ substructure + 2\ x\ pitch$

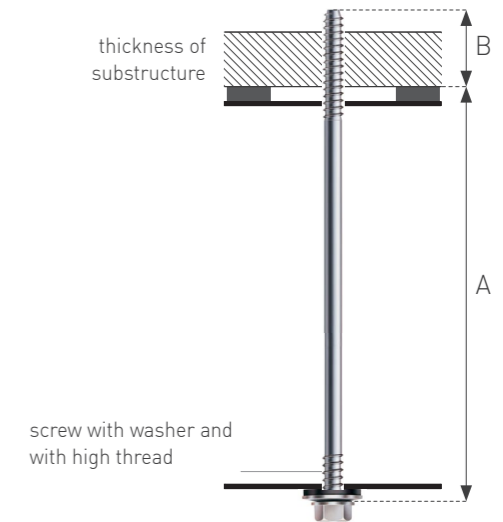

The right screw length for attachment through the whole thickness of Qbiss One element in case of using a self-tapping screw.

- $L_{min\ screw} = A+B$
- $A = Qbiss\ One\ element\ thickness\ (T) + 5\ mm$
- $B = thickness\ of\ substructure + 2\ x\ pitch + screw\ tip$

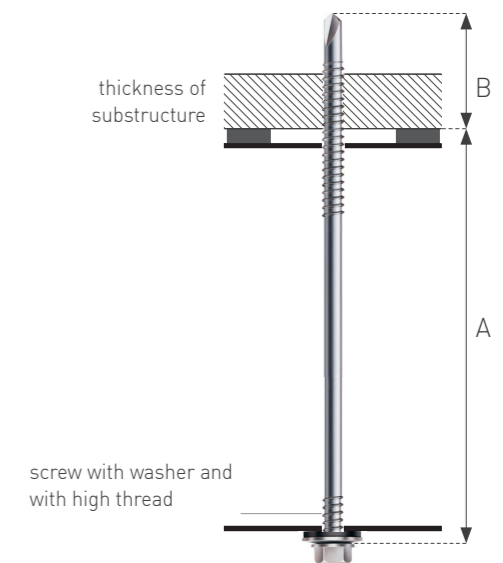

The right screw length for attachment through the whole thickness of Qbiss One element in case of using a self-drilling screw.

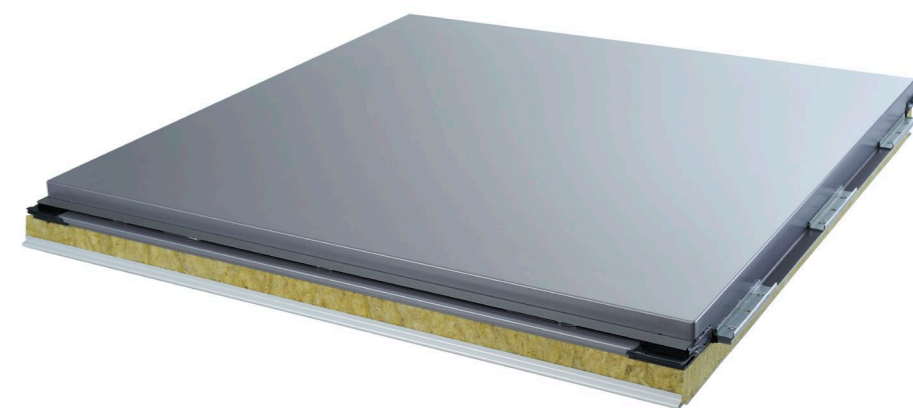

# INSTALLATION EQUIPMENT

## HANDLING AND LIFTING QBISS ONE ELEMENTS

In order to handle and lift the elements, vacuum grippers or special mechanical grippers attached to the longitudinal joint of the Qbiss One façade element is recommended. In order to perform the installation according to the instructions, special tools are required.

### VACUUM GRIPPERS

Swift pick up and accurate positioning greatly increases the installation speed.

Safety is primary, and our vacuum grippers are made according to the European standard and equipped with secondary safety devices. This can be performed using slings or with two (dual) independent vacuum circuits.

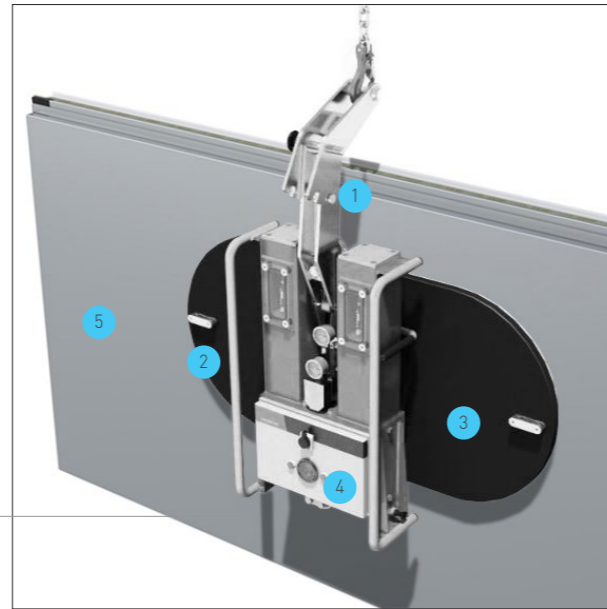

Vacuum gripper attached to the outer surface of the Qbiss One horizontal façade element.

- 1 Lifting eye
- 2 Solid grips
- 3 Suction cups
- 4 Controls
- 5 Qbiss One horizontally laid element

**!** Handle carefully! The installation team is responsible to check and use the correct type of vacuum grippers (octopus), suitable for lifting of self-supporting sandwich panels.

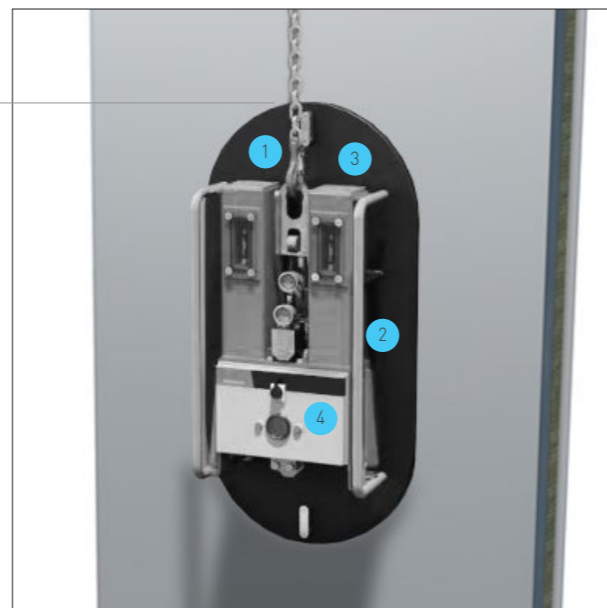

Vacuum gripper attached to the outer surface of the Qbiss One vertical façade element.

**!** Specific requirements for handling elements manufactured by Trimo.

- Manipulation must be carried out only by certified vacuum manipulators for panels.
- The maximum suction under pressure of vacuum suction cups is 30 kPa.
- For safe use, follow manufacturer's instructions.

## GRIPPER FOR QBISS ONE ELEMENTS

The purpose of use, i.e. safe and correct use of gripper for Qbiss One horizontal façades has been clearly defined in the instructions. Instructions for the grippers are included within the installation kit package. The gripper is produced by Trimo d.o.o., Prijateljeva cesta 12, Slovenia.

### IDENTIFICATION OF THE GRIPPER

The basic data about your device are marked on the identification plate fixed on the casing of the device. The following data are stated on it:

- producer,
- type of the device,
- load bearing capacity (max. loading allowed),
- serial number,
- year of production.

Interpretation of data stated in the identification plate of the gripper:

- Type PHQ \_\_\_\_: PHQ - Gripper for horizontal façade; width of the gripper or element thickness for which the gripper can be used are stated on the line. Possible width - thickness types are 80, 100, 120, 133, 150, 172, 200 and 240 mm.
- The allowed loading has been calculated for the elements of max. weight that can still be lifted by the gripper (The fact that elements longer than 1 m should be lifted by two grippers should be taken into account; the element of max. weight of 200 kg can be lifted and transported by a pair of grippers). For elements of the weight of 200 kg and more load carrier with 3 (max. 300 kg) or 4 grippers PHQ (400 kg) has to be used.
- Serial number \_\_\_\_: the running number of the gripper is stated on the line, e.g.: 001, 002, 003, etc.
- Year and month of production 20\_\_/\_\_: The year of production is indicated on the first line and the month of production is indicated on the second line; example: the gripper produced in August in the year 2002 is marked as: 2002/08.

### MARKS OF QBISS ONE GRIPPERS

Grippers for Qbiss One elements vary based on the thickness of element. The table shows required grippers based on element thickness. The data about the weight of an individual device are stated.

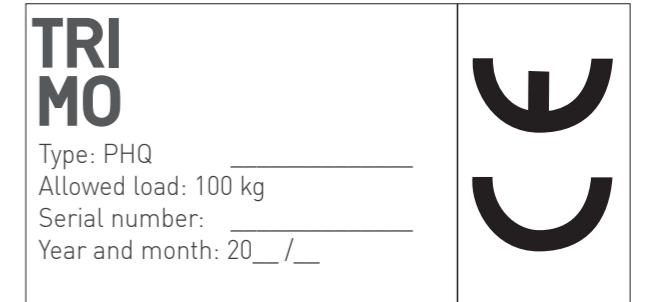

Identification plate

	Qbiss One (mm)	Mark (type) of the gripper	Gripper weight
1	80	PHQ - 80	1.9 kg
2	100	PHQ - 100	2.5 kg
3	120	PHQ - 120	2.7 kg
4	133	PHQ - 133	2.8 kg
5	150	PHQ - 150	3.3 kg
6	172	PHQ - 172	3.5 kg
7	200	PHQ - 200	4.5 kg
8	240	PHQ - 240	5.2 kg

Gripper marks regarding element thickness

**DESCRIPTION OF THE DEVICE**

The gripper is exclusively used as an auxiliary tool for horizontal installation of Qbiss One element. The use of the gripper for all other purposes is strictly prohibited.

Elements longer than 1m are to be handed by even number of grippers. The gripper ensures safe transport by its form and force between the latch and the cover that "squeeze" the element edge. The gripper cannot be universally used for all types of element thicknesses. Each nominal thickness of an element requires the use of a certain type of a gripper. They differ among each other only in width. The elements of nominal thickness of 80, 100, 120, 133, 150, 172, 200 and 240 mm are used for horizontal façades.

For elements heavier than 200 kg load carrier with more grippers PHQ must be used. For each 100 kg more one gripper has to be added. The system of element latching is equal in all gripper varieties. There is no need to remove core in case of standard element with 120 kg/m<sup>3</sup> or lower density core. In case of core with higher density mineral wool, the removal in gripping area is needed. Fill the gap with mineral wool before placing next Qbiss One element.

**DEVICE COMPONENTS**

The gripper consists of six components that represent a non-dismountable unit.

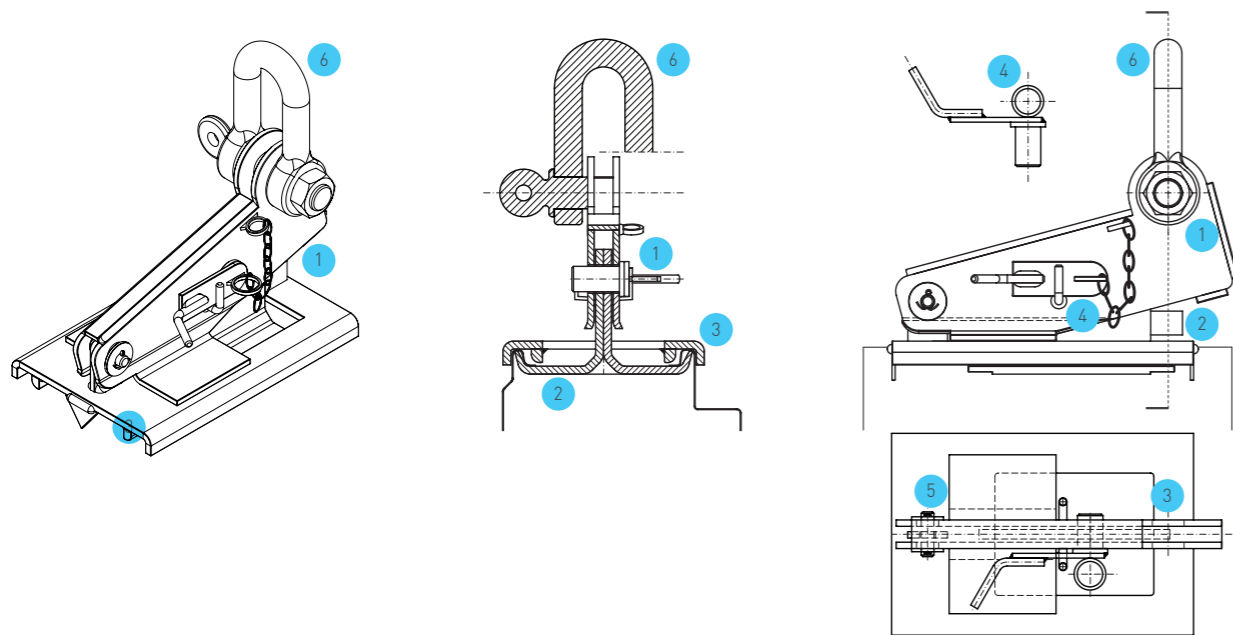

- 1 Holder of the gripper
- 2 Latch (left + right)
- 3 Cover
- 4 Pin with a protecting device
- 5 Pin with a protecting device
- 6 Lifting element (not a component of the device)

**SAFETY MECHANISMS / HUMAN FACTOR**

Gripper is a mechanical device without any rotating parts. The form of the latch prevents unexpected situation. A gripper produced exactly for this purpose should be used for the installation (see element type and type of gripper). Handling should not begin until the device is correctly placed on the element.

**SAFETY MECHANISMS / SYSTEM OF ELEMENT GRIPPING**

Element gripping is ensured by the form (by the form of the latch that is placed in the form of the element sheet metal) and friction between the element and gripper. The levering system has been designed so that the increase in the element weight lifted also increases the latching force.

Grasping of grippers PHQ is provided according to their shape (shape of a clasp, which fits into the shape of an element steel sheet) and by rubbing between element and a gripper. The distance between the grippers PHQ should make the angle, lower than 90° and higher than 60°.



**TRANSPORT AND STORAGE**

Grippers are transported individually and manually, one in each hand. Special attention should be paid during the transport since the device should not be dropped or should not damage feet and/or other parts of the body. When carrying and transporting three or more grippers these are transported in a case or any other packaging. Devices should not get mechanically damaged during the transport. When storing them, grippers are protected against meteorological influences and mechanical damage.

**OBLIGATIONS OF THE GRIPPER USER**

- Gripper can be used only for the purpose for which the gripper has been produced,
- Use of the gripper is allowed only in compliance with the producer's instructions,
- A person using the gripper should keep records of the gripper use,
- Persons must not stand under the element when it is being transferred with grippers PHQ.

**!** The device should be visually checked before use. If any mechanical defects are visible, the device should be eliminated from the working process. Any repair or replacement of damaged parts of the device is strictly prohibited. 🔑

**LOADING OF THE GRIPPER**

One gripper PHQ can be loaded by max. weight of 100 kg. A pair of grippers is always used for transporting the elements longer than 1 m. The allowed length / weight of elements (regarding element type) that can be transported by a pair of grippers is shown in the table Allowed dimensions - lengths are printed on white background.

The maximum allowed weight of an element that can be transported by an individual gripper is calculated with respect to the type and length of the element considering the element weight per m<sup>2</sup>.

The table shows that the gripper - type PHQ 240 can be used for transporting the elements of the length up to 4.0 m for the width of 1000 mm. The gripper - type PHQ 150 can be used for handling of elements up to 6.5 m long and 1000 mm wide.

Length	Qbiss One 100	Qbiss One 120	Qbiss One 133	Qbiss One 150	Qbiss One 172	Qbiss One 200	Qbiss One 220	Qbiss One 240	Qbiss One 250
2 m	47.8 kg	52.6	56.6	59.8	65.4	72.0	76.8	81.6	84.0
4 m	95.6 kg	105.2	113.2	119.6	130.8	144.0	153.6	163.2	168.0
6 m	143.4 kg	157.8	169.8	179.4	196.2	216.0	230.4	244.8	252.0
6.5 m	155.4 kg	171.0	184.0	194.4	212.6	234.0	249.6	265.2	273.0

Weight of the element regarding length and type (steel sheet 0.6/0.7 mm, MW 120 kg/m<sup>3</sup>, width 1000 mm).

The table below presents the data which might be used in control calculation of the element weight depending on its length.

	Qbiss One 100	Qbiss One 120	Qbiss One 133	Qbiss One 150	Qbiss One 172	Qbiss One 200	Qbiss One 220	Qbiss One 240	Qbiss One 250
Weight (kg/m <sup>2</sup> )	23.9	26.3	28.3	29.9	32.7	36.0	38.4	40.8	42.0

Weight of individual element type per m<sup>2</sup> (steel sheet 0.6/0.7, MW 120 kg/m<sup>3</sup>, width 1000 mm).

**!** The use of one gripper is exceptionally allowed in cases when façade elements are not longer than 1 m, but the gripper should be placed so that the centroidal axis runs over the lifting element.

Elements in length types that are marked in the hatched area should not be transported by the 2 grippers discussed. The elements heavier than 200 kg have to be transported by load carrier and additional grippers (3 PHQ for 200 - 300 kg, 4 PHQ for 300 - 400 kg, ...)

**MOUNTING OF GRIPPERS**

First Trimo sealing tape should be cut on the spot touching the gripper in the element edge and then the latches of grippers should be placed between the sheet metal faces of the element. Latches are pressed together, the holder is placed and a pin with a protecting device is inserted in the opening (the pin is inserted in the opening on the side where the load-bearing element for protecting chain of the pin is fixed). The distance between the grippers should be such that the angle is smaller than 90°, but greater than 60°.

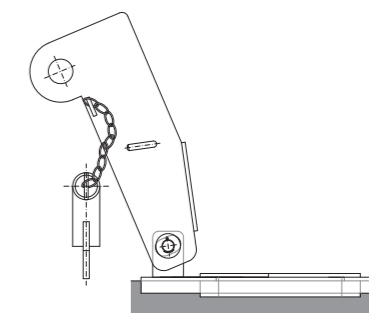

Mounting of a cover.

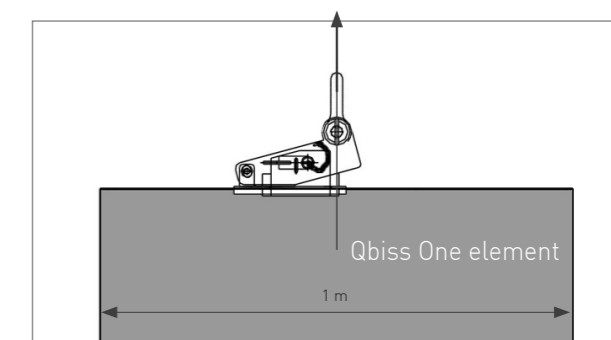

Use in case of façade elements up to 1 m long.

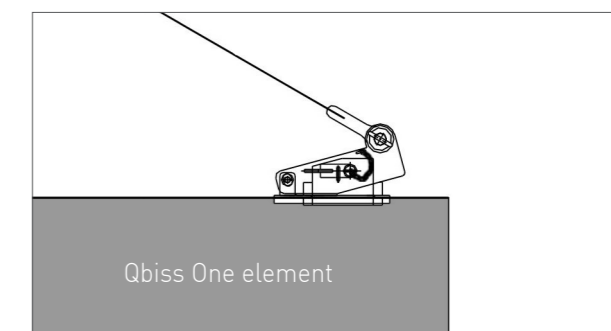

Correct direction of gripper mounting.



Standard elements (steel rope, lifting elements, etc.) are used as elements connecting the lifting device (lift) and gripper that is the subject of these instructions. Their characteristics (dimensions, latching systems) should be in compliance with the standards. These elements are not the subject of description in these instructions and are not components of the gripper.

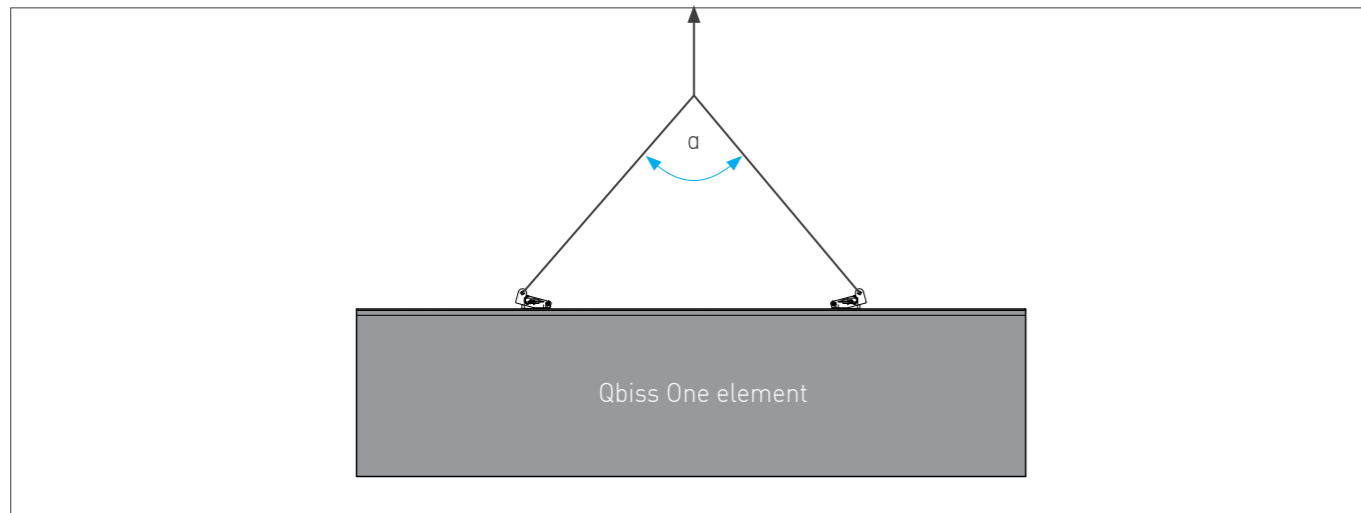

Mounting of a gripper pair PHQ.

**POSITIONING OF LATCHES**

Gripper is placed on the element with a pin drawn out and a holder lifted so that the cover of the gripper can be placed on the element edge. Latches are inserted in the bearing as it is presented in the drawing on the right (it is important that both latches are fixed). The holder of the gripper is placed over a pair of latches.

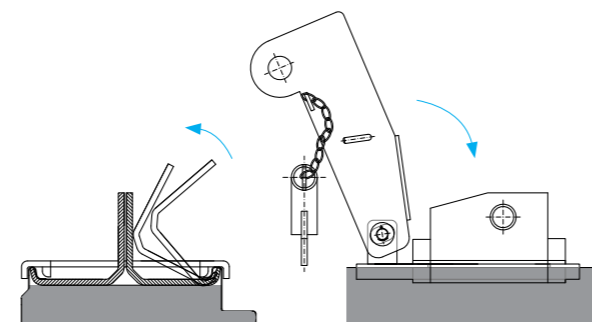

Positioning of latches and gripper holder PHQ in the façade element edge.

A safety pin is inserted in the opening between a holder and a gripper. Turn and lock the pin to prevent detachment. The pin is inserted from the side where the load-bearing element of the protecting chain of the pin is placed. Any other position of the safety pin is not correct.

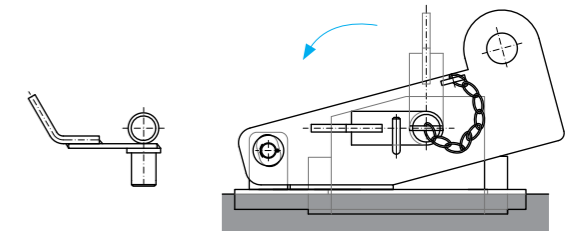

Insertion of a safety pin.

**FAÇADE ELEMENT LIFTING**

Lifting of the element should be carried out evenly and without any impact shocks. Beware that the bottom part of the element does not damage. Behaviour of the grippers should be monitored during the lifting process and in case of any unforeseen events lifting should be immediately stopped and mounting of grippers checked again.

**UNFASTENING OF GRIPPERS**

Unfastening of grippers is performed in the opposite direction to fastening. The gripper must be on the load-bearing rope during the complete procedure.

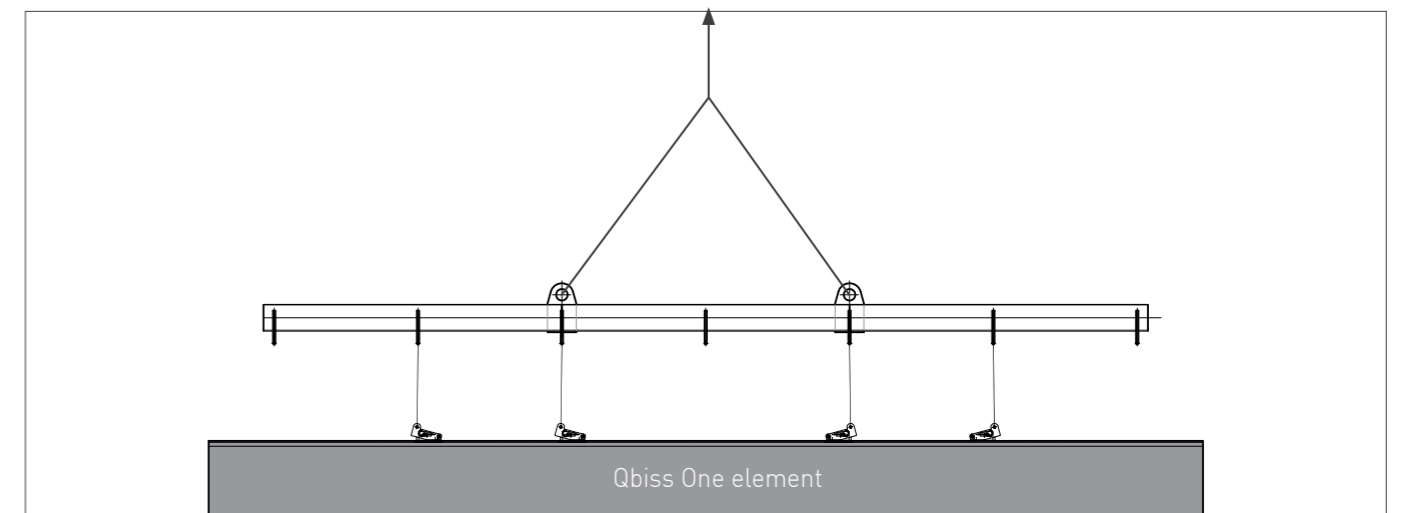

The element can be lifted from a pallet with a gripper or with a load carrier together with 3-4 grippers for Qbiss One elements heavier than 200 kg.

**MAINTENANCE**

Gripper should be protected against external (weather and mechanical) influences. The gripper that gets very abraded during the use should be protected against the corrosion. Before each use, gripper should be visually checked. If any deformations of the load-bearing elements (safety pin, latches, cover, holder) are observed they should be measured.

**GRIPPER LIFE-CYCLE**

When the gripper has lifted 5.000 m<sup>2</sup> Qbiss One or after one year of use of the device should be eliminated from use (Records of gripper use). If it is established during daily checking that individual parts are worn and torn and exceed 1 mm over the normal status, the gripper should be eliminated from further use.

Kind of checking	Kind of activity	Place of checking	Method of performance	Performer	Note
Daily	Control checking of wear and tear	Complete device	Visual	Operator - connecting person	See maintenance
Half-yearly	Cleaning, anticorrosion protection	Complete device	Visual, anticorrosion protection if required	Operator - connecting person	See maintenance

Control page.

For more details on packing, manipulation, transportation and storage of Qbiss One elements please visit:

 [Packing, transport and storing for Trimo products](#)

**!** Use protection gloves when using the gripper. Do not wear loose clothing when using lifting gripper. Check element weight and determine required number of lifting grippers before use. After grippers have been mounted and before lifting, all persons should move away and back, safety distance should be kept - danger of element swinging, function defect. In case of wind, the grippers must not be used.



ORTERER GRUPPE HEADQUARTERS  
GERMANY

VERTICAL QBISS ONE

2016  
KEHRBACH PLANWERK

### INSTALLATION TOOLS

In order to perform installation according to the instructions, the following tools must be used. Please prepare them before starting the installation:

- For a horizontal and vertical alignment of the substructure the following tools: laser, bulb level, plumb can be used.
- A drilling device (to drill holes for screws).
- Drill bits (to drill holes for screws).
- Wrenches / attachments (for tightening the screws).
- Cutting tools (metal shears, circular saw, jigsaws etc.)
- Hammer (for inserting the transversal rubber gasket and the decorative aluminium extrusion).

### CUTTING THE ELEMENTS

Cutting and trimming of parts of Qbiss One façade elements can only be performed for various openings (e.g. doors, windows, infrastructure openings etc.). In these cases, only metal shears and saws that do not over-heat the metal at the cutting site may be used. Circular saw use is recommended.



Cutting of elements is only permitted when using shears or saws.

- !
- Do not mark the surface with sharp objects that would damage the protective colour layer.
  - Using cutting tools and welding destroys the corrosion protection.
  - Small metal particles that appear as a result of cutting and drilling must be immediately removed from the surfaces of façade elements by completion of the day's work at the latest (metal particles exposed to moisture cause corrosion).

### INSTALLATION TOOL KIT

Installation kit is available for vertically and horizontally laid Qbiss One façade elements.

- 1 Installation centring cross (for achieving the right spacing between the elements)\*
- 2 Syringe with soap-water solution (for correct insertion of the transversal gasket)\*
- 3 Wooden bar with protective felt (for inserting the transversal rubber gasket and the decorative Alu. extrusion)\*
- 4 EPDM drip element
- 5 Attachment screw for Qbiss One façade elements
- 6 EPDM transversal gasket
- 7 Decorative Alu. extrusion (HF-40, HF-52)
- 8 Vertical load fixing screw (for fixing through element internal metal sheet)
- 9 EPDM cube gasket
- 10 Junction drip element (drip flashing for a joint of 4 Qbiss One façade elements)
- 11 Joint profile (in case of vertically laid Qbiss One elements)
- 12 Load bearing fixing plate
- 13 Short Qbiss One book extraction from instructions for installation\*

\* Delivered with the required number of units (included in a standard installation kit package).

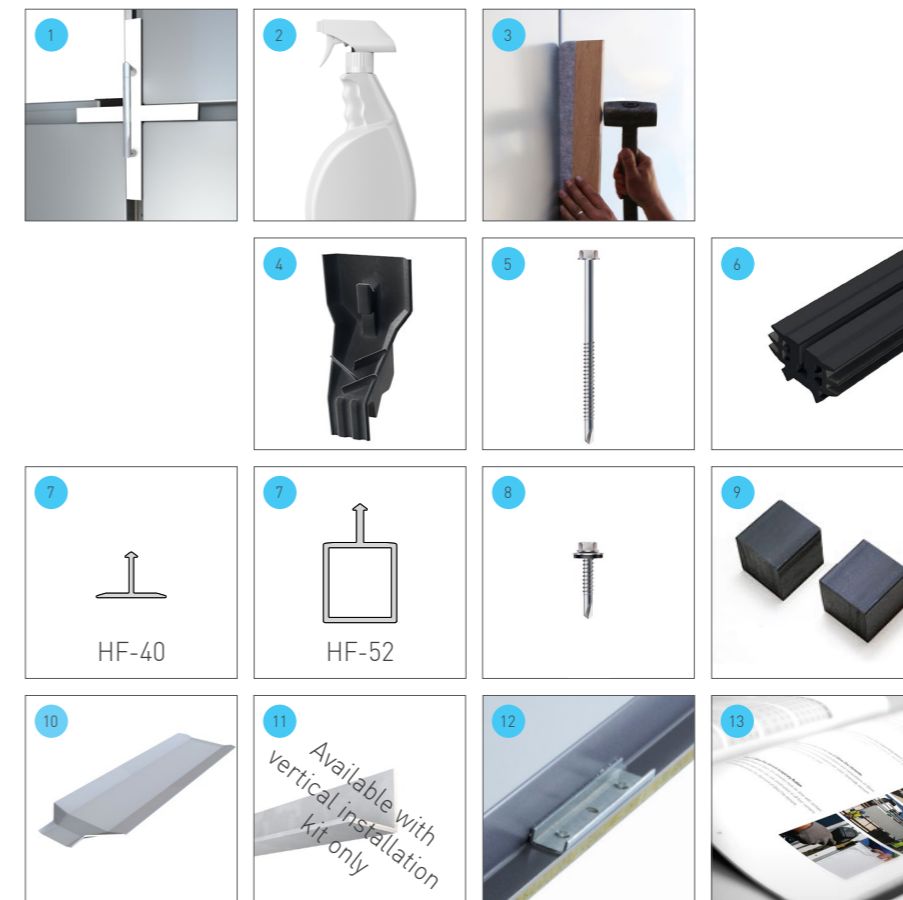

# PREPARATION FOR INSTALLATION

## REMOVING THE PROTECTIVE FOIL

Qbiss One façade elements have a protective foil on outer and optionally on inner surface to protect the coloured surfaces against eventual minor scratches during transport, handling and installation.

Immediately before placing Qbiss One façade element onto the building site, you must:

- Completely remove the protective foil from the backside.
- At the element's front side, partially remove the protective foil at the attachment site, on both longitudinal joints, under the linings etc.
- Every day after ending of the installation, the foil must be completely removed from each façade element / façade.



Removing of the protective foil

- ! If Qbiss One façade elements are in storage for longer periods of time the foil must be removed after three months at the latest.
- When storing Qbiss One façade elements outside, they must be protected from direct sunlight, otherwise, the foil cannot be removed completely.
- At the time of installation, the foil must be removed from all joints of Qbiss One façade elements.
- Every day after ending the installation, the foil must be completely removed from each façade element / façade.

- ! Façade elements must be protected from water and other liquids seeping into the insulation during unloading, right through to the end of the installation.

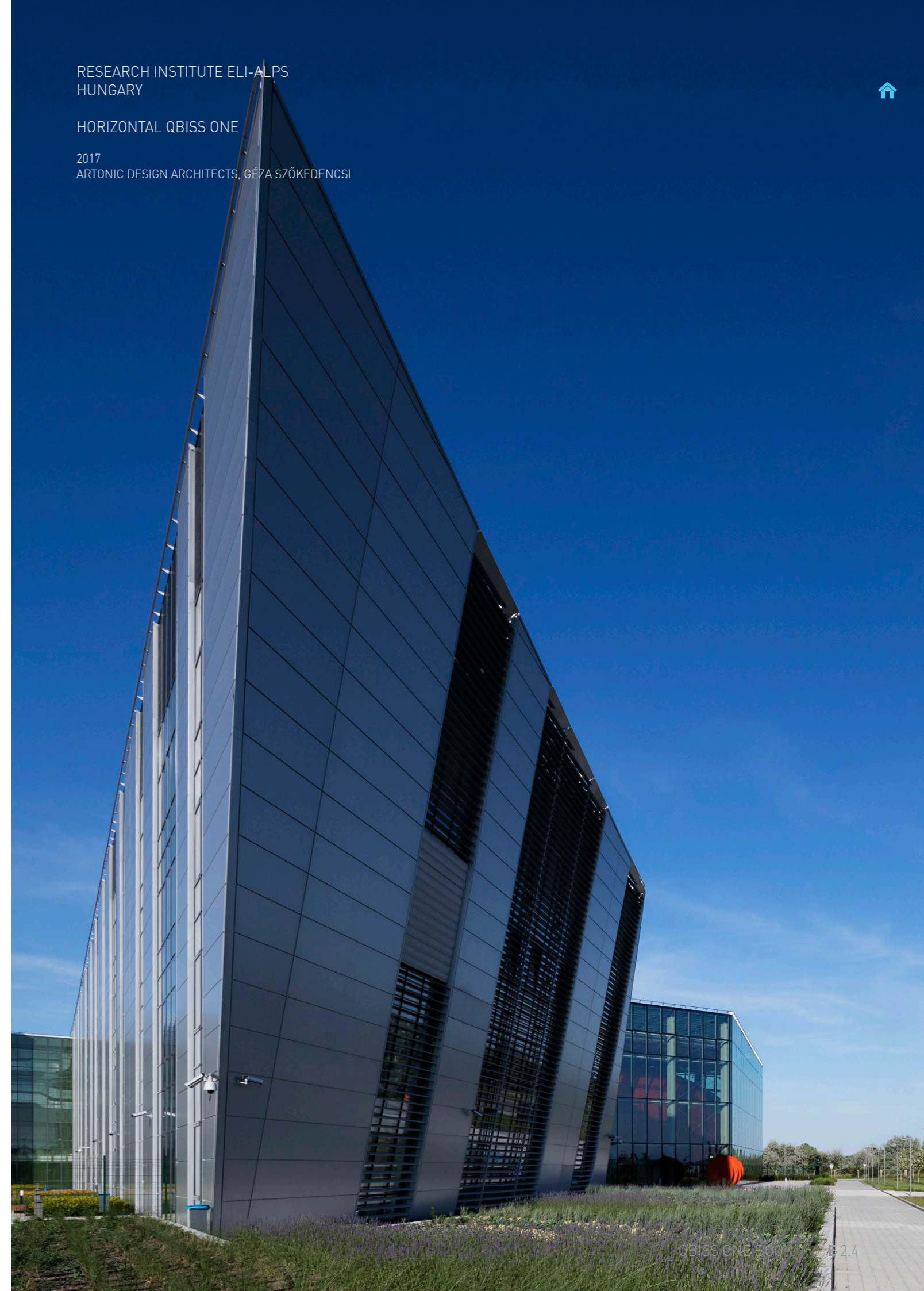

# INSTALLATION PREFERENCES

## INSTALLATION AND CONTROL OF THE MAIN STRUCTURE OR SUBSTRUCTURE

The support of the ending of the Qbiss One façade system must be horizontally aligned, otherwise, the vertical joints will not be of the same width. If the substructure is already installed, the substructure distances must nevertheless be checked (check the distances between vertical supports). The secondary substructure must be installed with the tolerance of  $\pm 2$  mm.

### THE MEASUREMENT PROCEDURE TO ENSURE THE HORIZONTAL ALIGNMENT OF BASIC LOAD-BEARING ENDING



The permissible deviations of alignment for the base load-bearing ending must meet two requirements:

- Permissible deviation along the whole length of individual Qbiss One façade elements is  $\pm 0.5$  mm.
- Permissible deviation of alignment of the complete building façade is  $\pm 2$  mm.

! It is crucial to ensure that the contact surface of the first row of Qbiss One façade elements is in level, otherwise, irregular vertical placing of Qbiss One elements will occur, causing size increases of transversal joints. Consequently, the transversal joints will not be properly sealed, which enables water ingress to the inside of the façade system.

## THE MEASUREMENT PROCEDURE TO ENSURE THE VERTICAL ALIGNMENT OF THE STRUCTURE / SUBSTRUCTURE

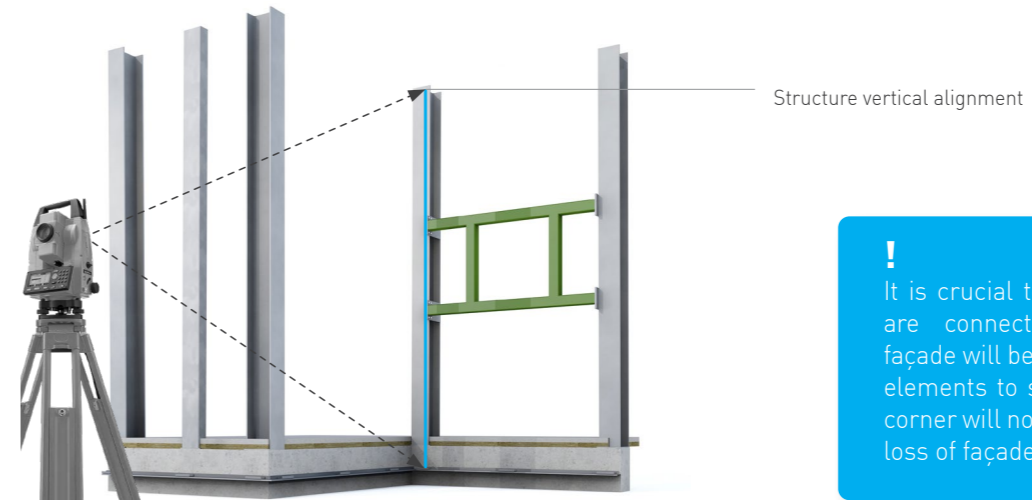

! It is crucial to ensure that corner elements are connected properly; otherwise, the façade will be at an angle, causing the corner elements to stack incorrectly. Consequently, corner will not be finished properly, leading to loss of façade system water tightness.

## PERMISSIBLE DEVIATIONS OF SUBSTRUCTURE FOR QBISS ONE ELEMENTS

### PERMISSIBLE DEVIATIONS OF THE VERTICAL LINE IN GROUND PLAN

- $\Delta 1 = \pm 2$  mm deviation of the vertical substructure in ground plan from the building axis
- $\Delta 2 = \pm 2$  mm deviation of the distance between two adjacent verticals in ground plan

$\Delta$  Distance from actual to ideal coordinate point, line or other geometric property.

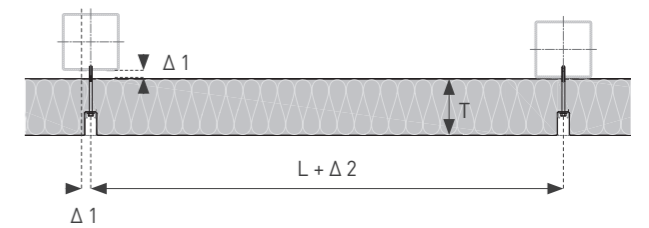

Deviation of the vertical line in ground plan.

### THE PERMISSIBLE DEVIATIONS OF THE VERTICAL LINE TO THE LINE CONNECTING ITS ADJACENT VERTICALS

L (m)	$\Delta 3$ (mm)
1	$\pm 2$
2	$\pm 2$
3	$\pm 2$
4	$\pm 2$
5	$\pm 2$
6	$\pm 2$
7	$\pm 2$

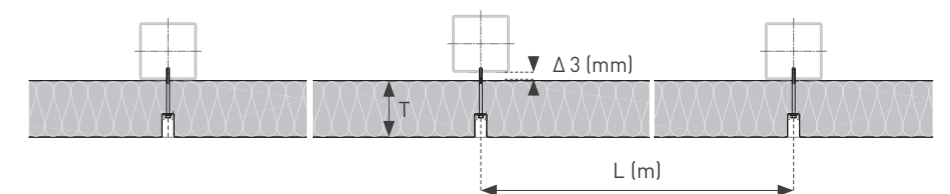

Deviation of the vertical line to the line connecting its adjacent verticals.

# QBISS ONE SITE MEASUREMENTS

## PRODUCTION OF QBISS ONE ELEMENTS AFTER SITE MEASUREMENTS

Design dimension of the main structure do not always translate to the elements on a construction site. In order to compensate deviations between actual and design dimensions it is recommended to produce Qbiss One elements after site measurements.

Production of flat Qbiss One B-B elements after site measurements:

- A** Install first row of façade elements.
- B** Make a site measurements and send it to production to minimise impact on time schedule.
- C** Continue with installation of remaining rows while façade elements are being produced.
- D** Install the last column upon delivery.

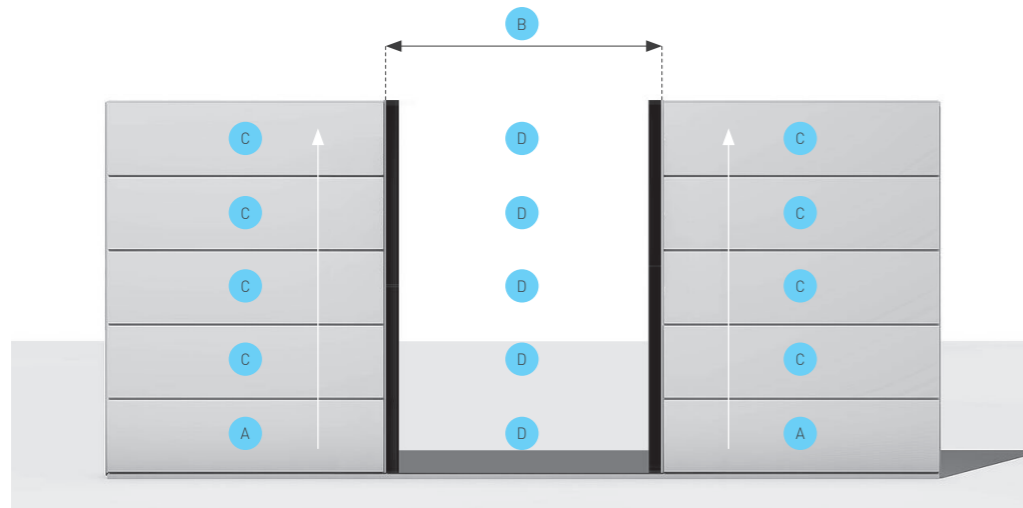

R - Design length  
M - Module width  
T - Qbiss One element thickness

## HOW TO MEASURE FLAT QBISS ONE B-B ELEMENT

1. Consider façade element joints
2. Measure  $R = L - 25 \text{ mm}$

Example Qbiss One B-B element format BOTH-SIDED; Installation direction Left-Right.

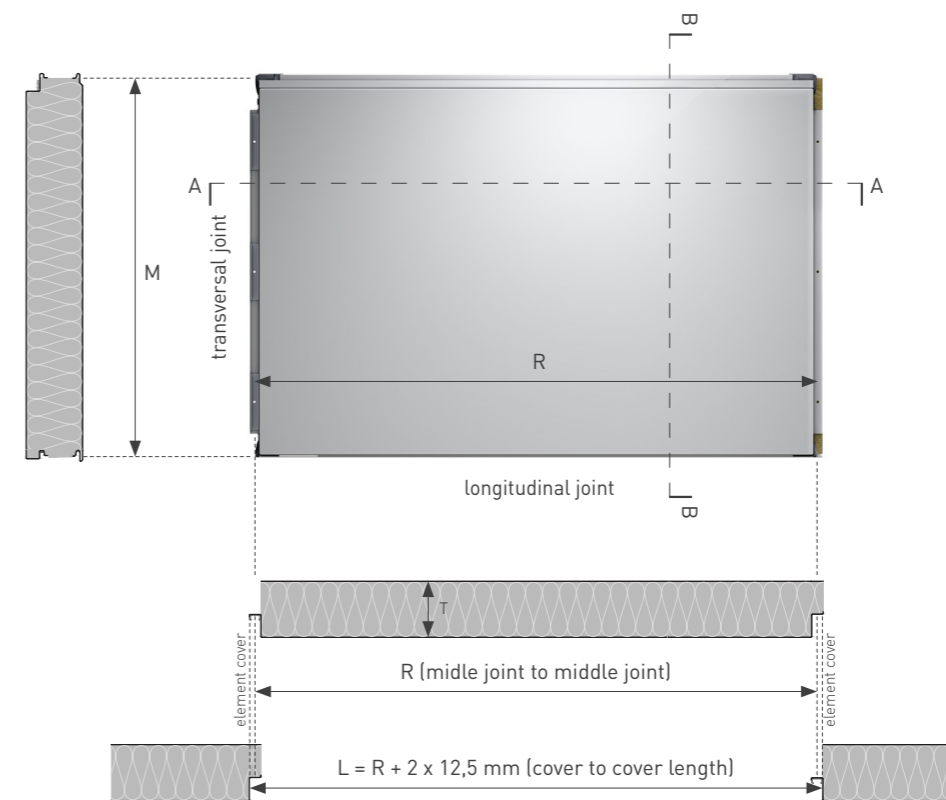

R - Design length  
M - Module width  
T - Qbiss One element thickness

Production of Qbiss One B-B corner elements after site measurements:

- A**  
Install first row of façade elements.
- B**  
Make a site measurements and send it to production to minimise impact on time schedule.
- C**  
Continue with installation of remaining rows while façade elements are being produced.
- D**  
Install the last column upon delivery.

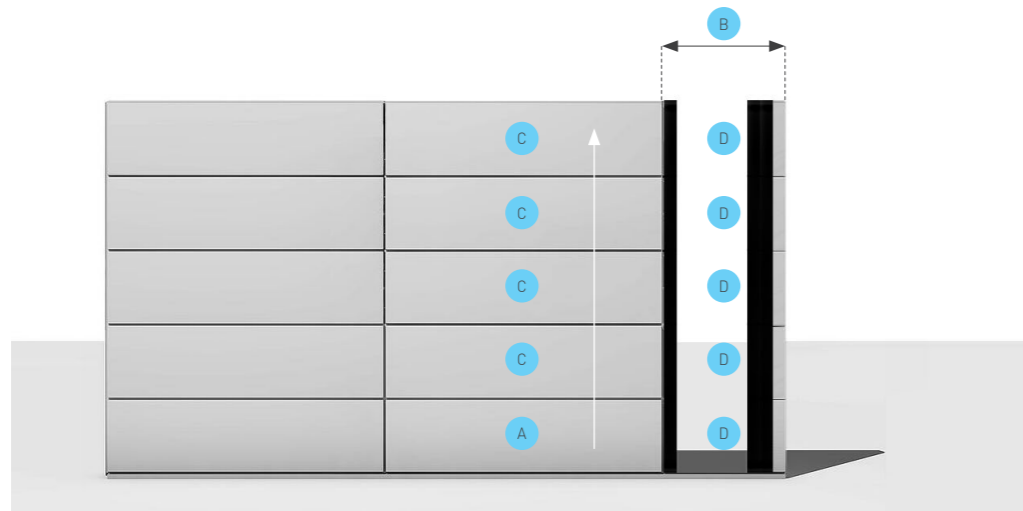

R - Design length  
M - Module width  
T - Qbiss One corner thickness

**HOW TO MEASURE TRANSVERSAL CORNERS**

- Consider façade element joints
- Measure and enter to cutting list  
 $A = L_A - 12,5 \text{ mm}$   
 $B = L_B - 12,5 \text{ mm}$

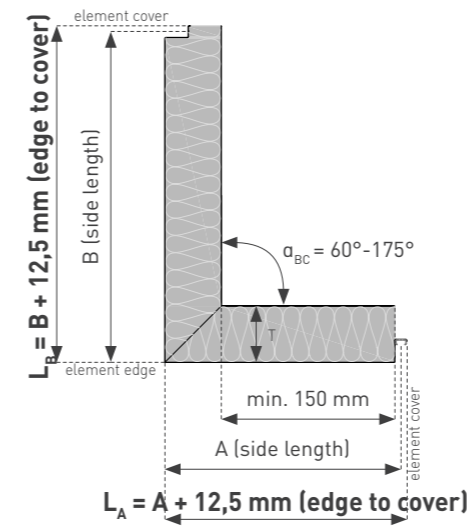

Qbiss One transversal corner element.

**HOW TO MEASURE LONGITUDINAL CORNERS**

- Consider façade element
- Measure and enter to cutting list  
 $A,$   
 $B$  and  
 $M = A + B$

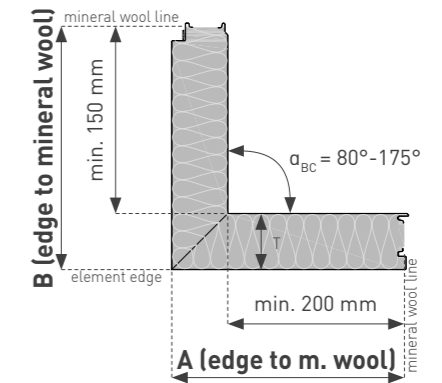

Qbiss One longitudinal corner element.

# ARCHITECTURAL DETAILS

## DEFAULT SETTING

Qbiss One installation guide should be read in conjunction with project specific design drawings. It can be used as a generic guide explaining most common and preferable way of Qbiss One façade element application. Installation guide is available for horizontally in vertically laid Qbiss One elements. All element joint variations follow the same basic Qbiss One B-B system installation steps.

- Main load bearing structure is made of steel euro profiles.
- Parapet wall detail is solved to adjacent Trimo roof system.
- Scheme's substructure is installed by using adjustable profiles.
- Base detail is connected to reinforced concrete plinth.
- Element manipulation is performed by using vacuum lifting tool or grippers.
- In case of horizontally laid elements, corner element installation is performed before adjacent element are placed.
- In case of vertically laid elements, corner element is in line with left to the right element installation direction.
- Colours in diagrams are chosen to offer better representation and element distinction.
- Window and door setting is performed by modular fitting.

Details on this media are selected out of proven, typical Qbiss One details.

### HORIZONTAL INSTALLATION DETAILS SCHEME

- QO-H-01-2 joint
- QO-H-01-3 brick system
- QO-H-02 base
- QO-H-03 parapet
- QO-H-04 external corner
- QO-H-05 internal corner
- QO-H-06 window
- QO-H-07 door
- QO-H-09 dilatation
- QO-H-11 other system connection

### VERTICAL INSTALLATION DETAILS SCHEME

- QO-V-01-1 joint
- QO-V-01-2 brick system
- QO-V-02 base
- QO-V-03 parapet
- QO-V-04 external corner
- QO-V-05 internal corner
- QO-V-06 window
- QO-V-07 door
- QO-V-09 dilatation
- QO-V-11 other system connection

## HORIZONTAL DETAILS OVERVIEW

Architectural details not only increase design efficiency, but shorten the design process. They ensure the stunning appearance of the building with more than 500 different typical details available. Architectural details on this media are selected out of the standard Qbiss One horizontal details. If default element setting is changed, installation procedure might vary.

### Documentation download centre

-  [CAD download centre](#)
-  [BIM download centre](#)
-  [Installation videos channel](#)

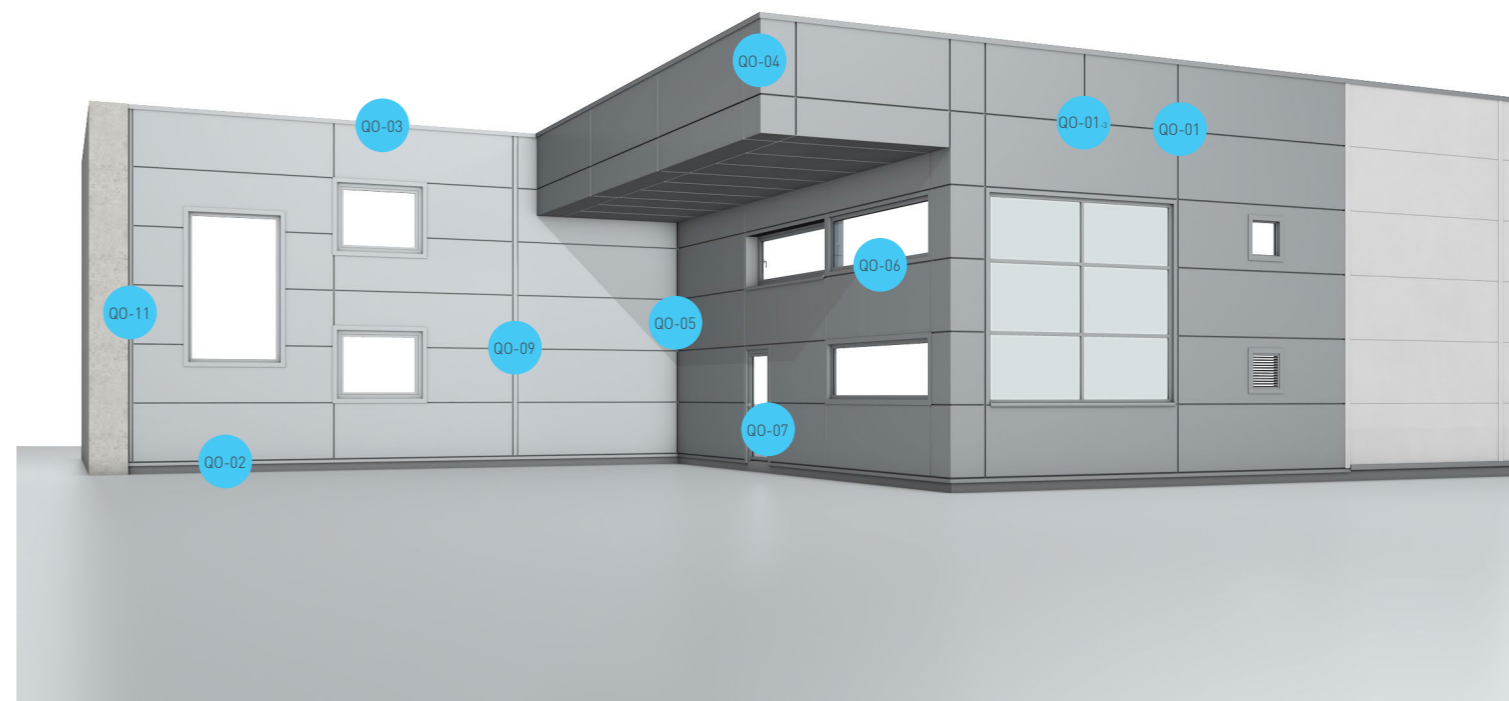





# HORIZONTAL INSTALLATION

## QBISS ONE

### JOINT TYPE

- B - B     BF - BF
- B - BF     F - B
- BF - B     F - BF

### BUILDING APPLICATION

- External Facade     External Soffit
- Internal Wall     Internal Ceiling

#### HORIZONTAL CUT

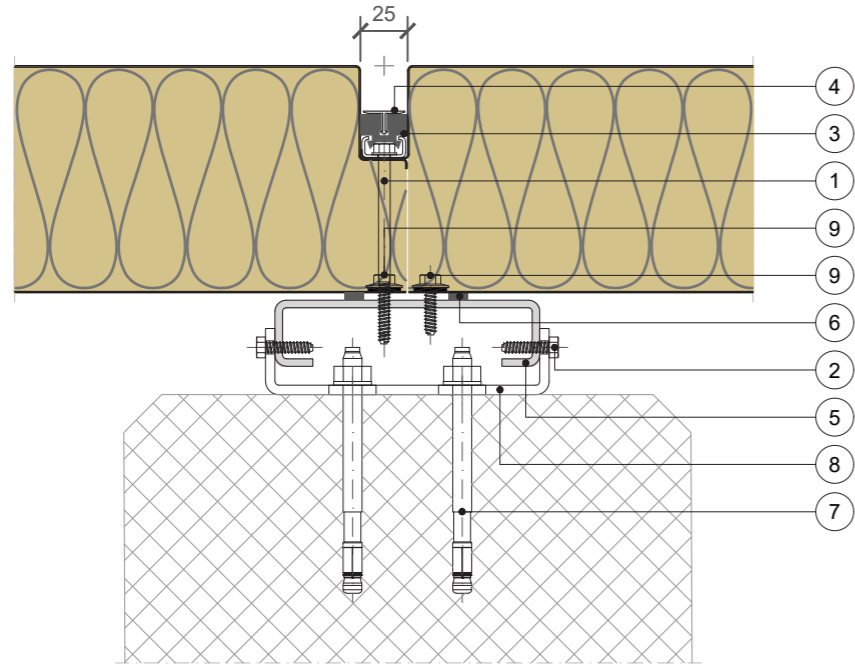

#### VERTICAL CUT

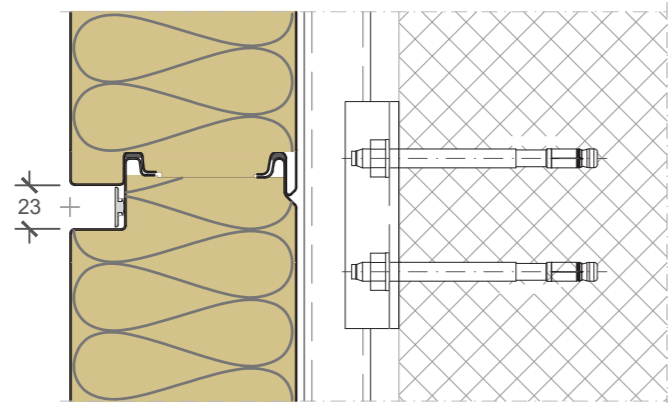

#### NOTE

- Direction of installation needs to be specified.
- The detail is suitable for substructure within  $\pm 2$  mm tolerance.
- Adjustable substructure to be used when tolerances are out of range.

POS.	ELEMENTS	SCALE: M 1:4
1	Fixing screw	
2	Fixing screw	
3	EPDM Transversal gasket	
4	Decorative ALU extrusion	
5	Fast fixing adjustable leveling substructure - supporting	
6	Sealing tape	
7	Anchor bolt	
8	Fast fixing adjustable leveling substructure - load bearing	
9	Fixing screw	

## JOINT

Trimo Group holds full copyrights on the information and details provided on this media, therefore any unauthorized reproduction and distribution is strictly prohibited.



# E. INSTALLATION GUIDE

## ARCHITECTURAL DETAILS

### 3D DETAIL Q0-H-01.02

**Joint detail** of Qbiss One façade element contains integrated corner gasket as part of Trimo patented sealing system. Sealing of the transversal joint is accomplished by using an inserted sealing and decorative Alu. extrusion.

[CAD download centre](#)





# HORIZONTAL INSTALLATION

## QBISS ONE

### JOINT TYPE

- B - B    ○ BF - BF
- B - BF    ○ F - B
- BF - B    ○ F - BF

### BUILDING APPLICATION

- External Facade    ○ External Soffit
- Internal Wall    ○ Internal Ceiling

HORIZONTAL CUT

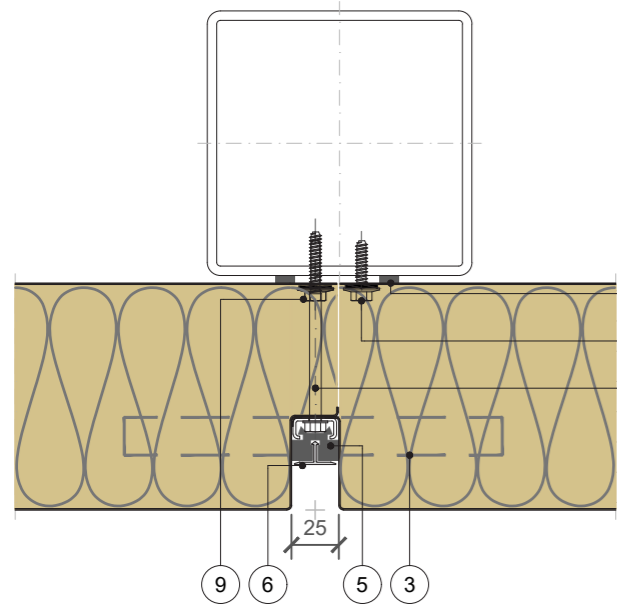

VERTICAL CUT

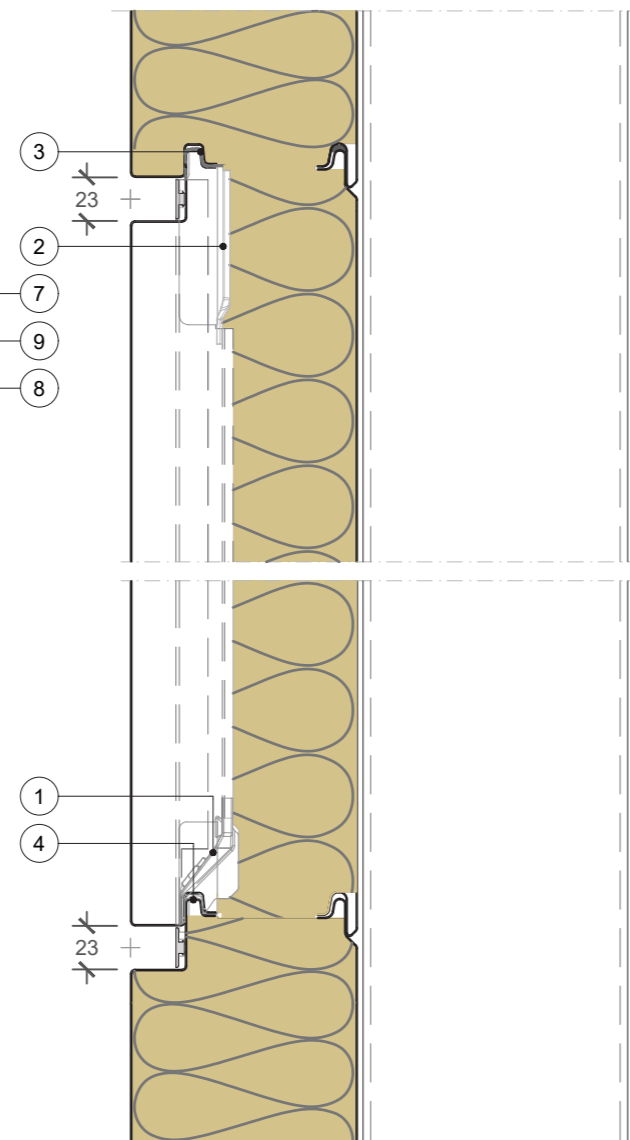

BRICK SYSTEM

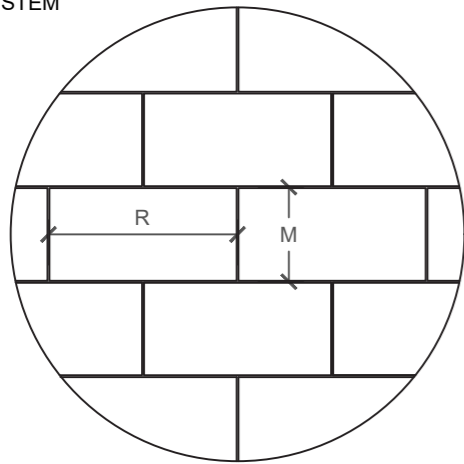

### NOTE

- Direction of installation needs to be specified.
- The detail is suitable for substructure within  $\pm 2$  mm tolerance.
- Adjustable substructure to be used when tolerances are out of range.

POS.	ELEMENTS	SCALE: M 1:4
1	EPDM drip element	
2	Junction drip element	
3	Alu-butyl tape	
4	Sealing / gluing putty	
5	EPDM Transversal gasket	
6	Decorative ALU extrusion	
7	Sealing tape	
8	Fixing screw	
9	Fixing screw	

## JOINT

Trimo Group holds full copyrights on the information and details provided on this media, therefore any unauthorized reproduction and distribution is strictly prohibited.



# E. INSTALLATION GUIDE

## ARCHITECTURAL DETAILS

### 3D DETAIL Q0-H-01.03

**Brick system** enables element to be shifted by a portion of the length of the bottom element. For sufficient sealing PE-butyl tape (1) and EPDM drip element (2) must be applied.

[CAD download centre](#)

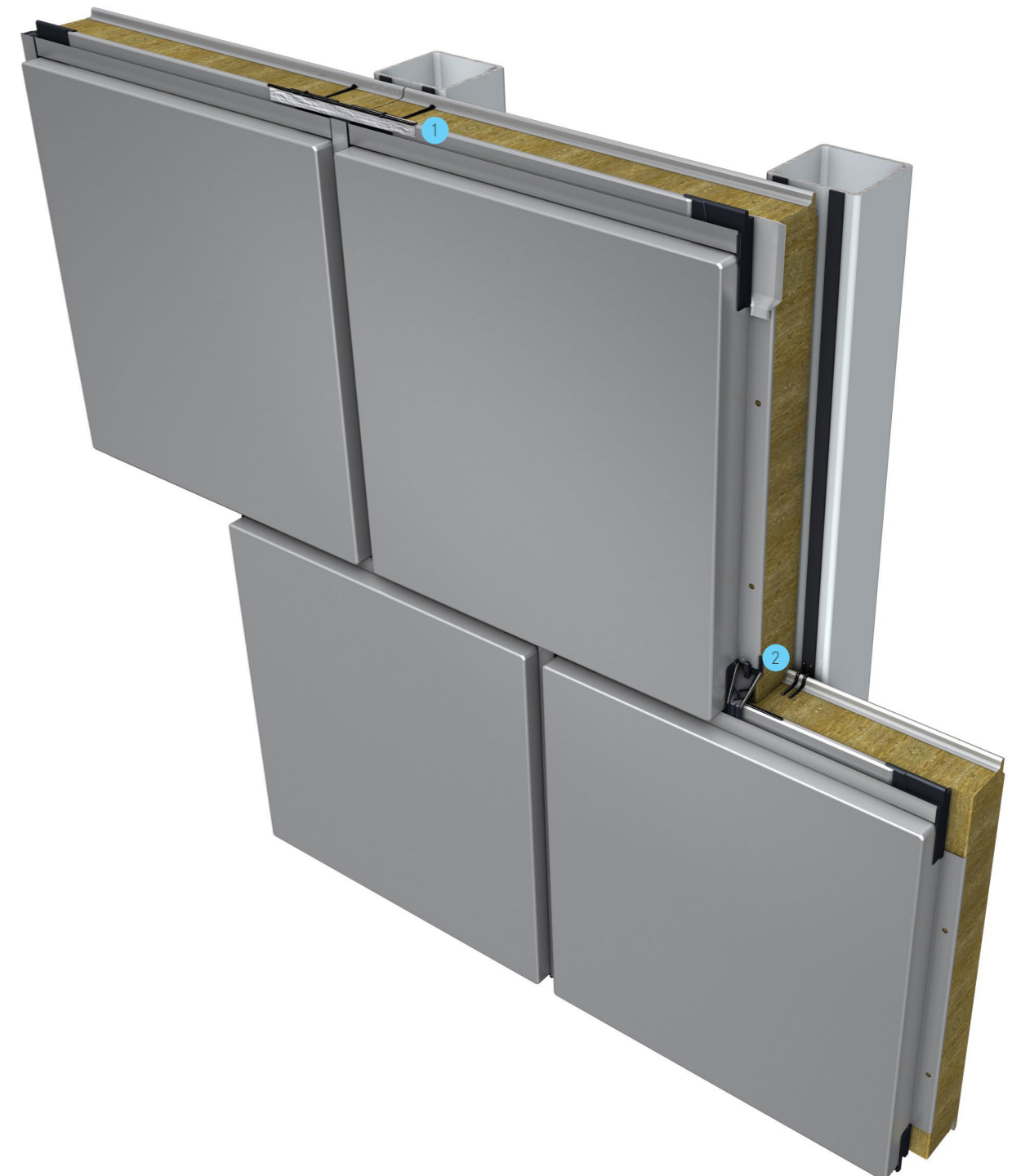



# HORIZONTAL INSTALLATION

## QBISS ONE

### JOINT TYPE

- B - B     BF - BF
- B - BF     F - B
- BF - B     F - BF

### BUILDING APPLICATION

- External Facade     External Soffit
- Internal Wall     Internal Ceiling

VERTICAL CUT

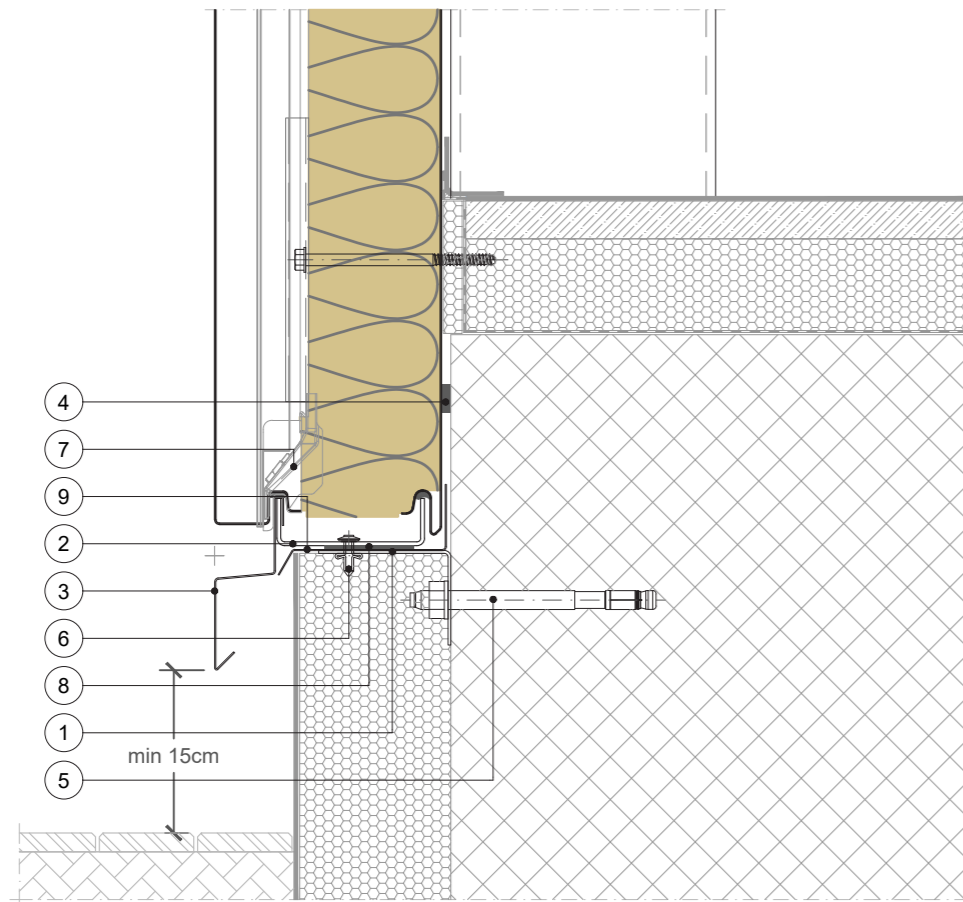

### NOTE

- The detail is suitable for substructure within  $\pm 2$  mm tolerance.
- Adjustable substructure to be used when tolerances are out of range.

POS.	ELEMENTS	SCALE: M 1:4
1	Cladding element holder L profile	
2	Element bearers	
3	Drip flashing	
4	Sealing tape	
5	Anchor bolt	
6	Bulb tite rivet	
7	EPDM drip element	
8	Sealing tape EPDM	
9	Drip flashing	

## BASE

Trimo Group holds full copyrights on the information and details provided on this media, therefore any unauthorized reproduction and distribution is strictly prohibited.



# E. INSTALLATION GUIDE

## ARCHITECTURAL DETAILS

### 3D DETAIL Q0-H-02.01

**Base system** detail EPDM drip element component, prevents the entry of rain water and drains any eventual water from the joint. Transversal joint serves as a drain duct.

[CAD download centre](#)

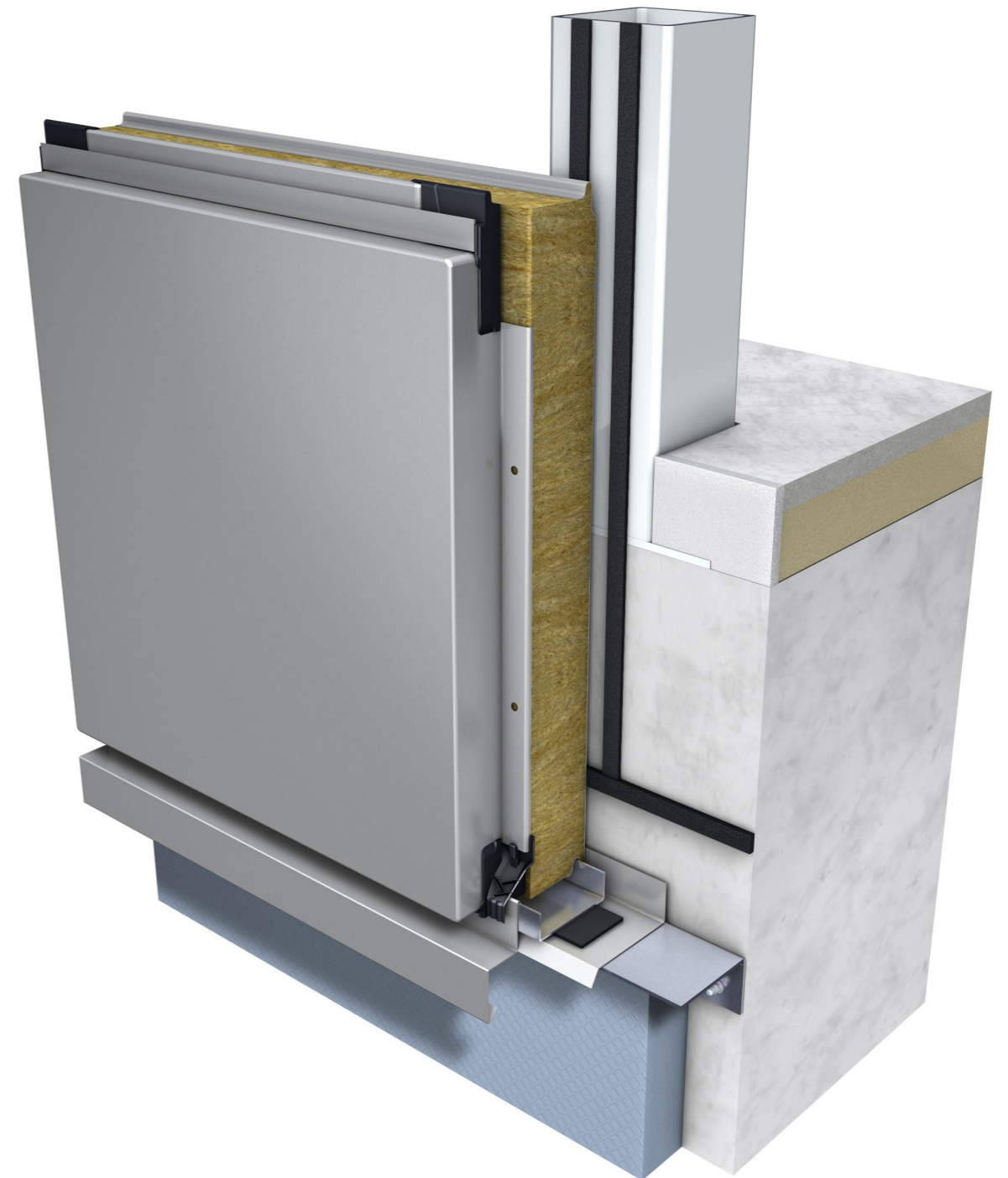



# HORIZONTAL INSTALLATION

## QBISS ONE

VERTICAL CUT

### JOINT TYPE

- B - B     BF - BF
- B - BF     F - B
- BF - B     F - BF

### BUILDING APPLICATION

- External Facade     External Soffit
- Internal Wall     Internal Ceiling

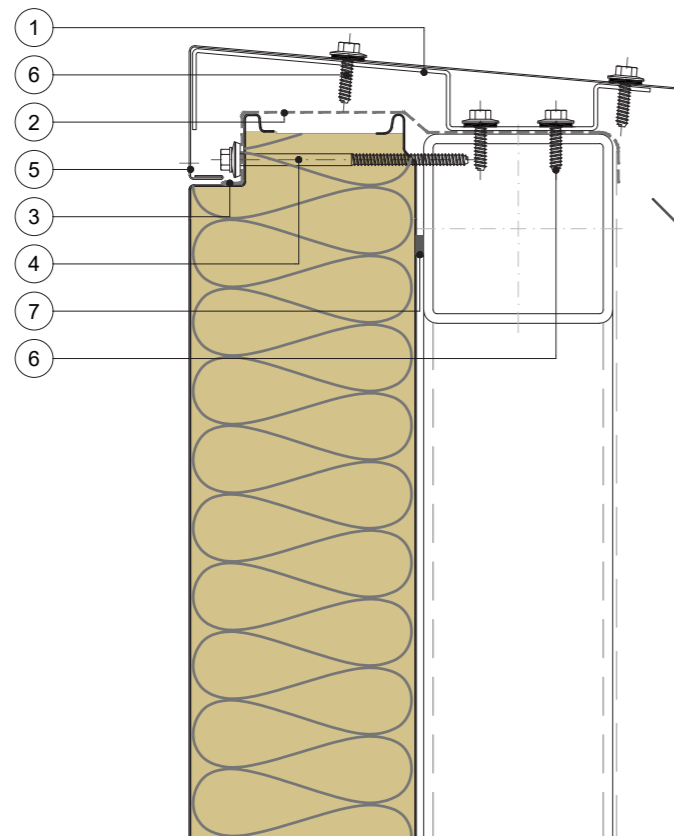

### NOTE

- The detail is suitable for substructure within  $\pm 2$  mm tolerance.
- Adjustable substructure to be used when tolerances are out of range.

POS.	ELEMENTS	SCALE: M 1:4
1	Parapet cap support profile	
2	EPDM membrane	
3	EPDM membrane glue	
4	Fixing screw	
5	Parapet cap	
6	Fixing screw	
7	Sealing tape	

## PARAPET

Trimo Group holds full copyrights on the information and details provided on this media, therefore any unauthorized reproduction and distribution is strictly prohibited.



# E. INSTALLATION GUIDE

## ARCHITECTURAL DETAILS

### 3D DETAIL Q0-H-03.01

**Parapet** detail finish is performed using a parapet wall cap. The sealing is performed by finishing joint elements in the transversal joint.

[CAD download centre](#)

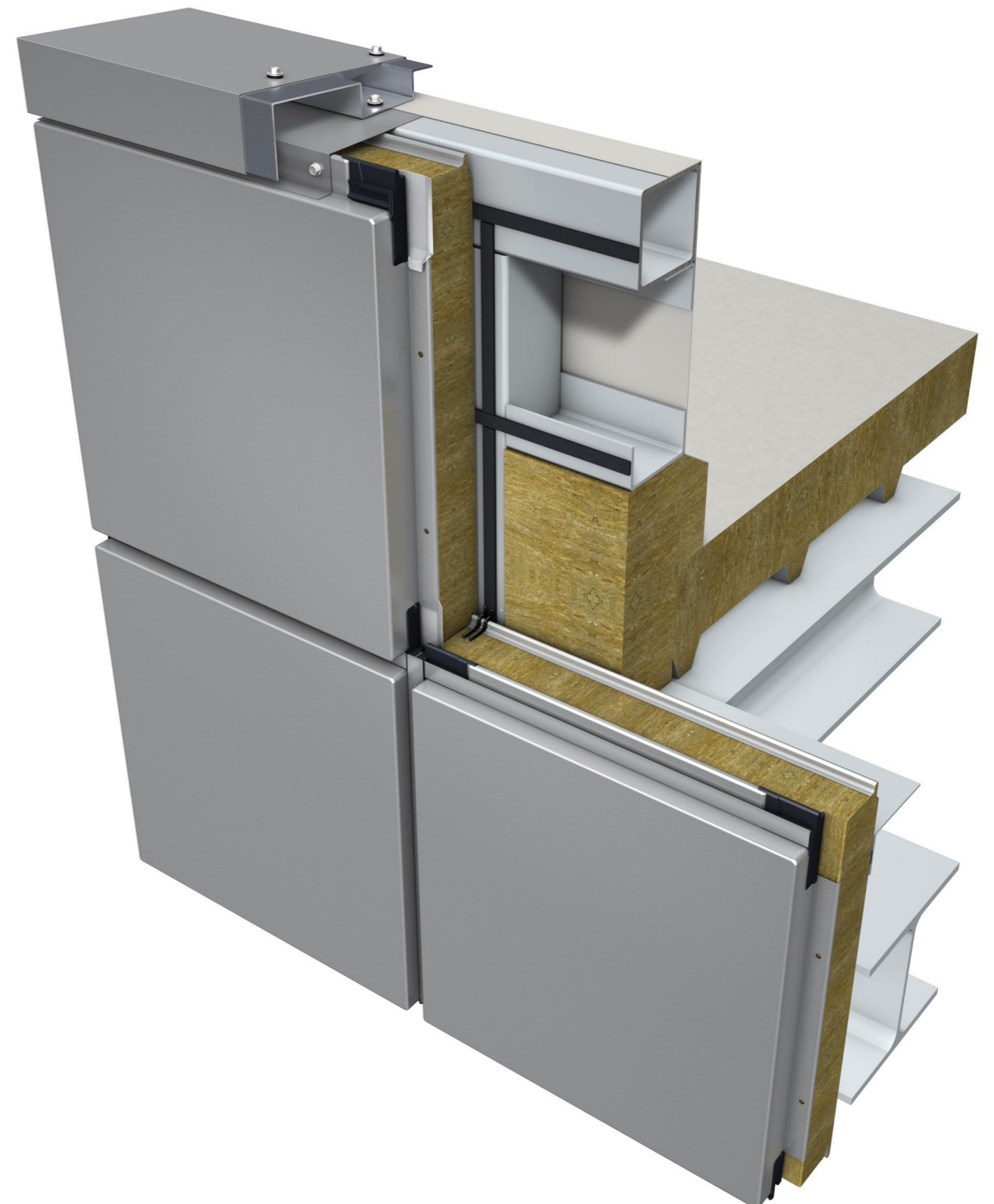



# HORIZONTAL INSTALLATION

## QBISS ONE

### JOINT TYPE

- B - B    ○ BF - BF
- B - BF    ○ F - B
- BF - B    ○ F - BF

### BUILDING APPLICATION

- External Facade    ○ External Soffit
- Internal Wall    ○ Internal Ceiling

### HORIZONTAL CUT

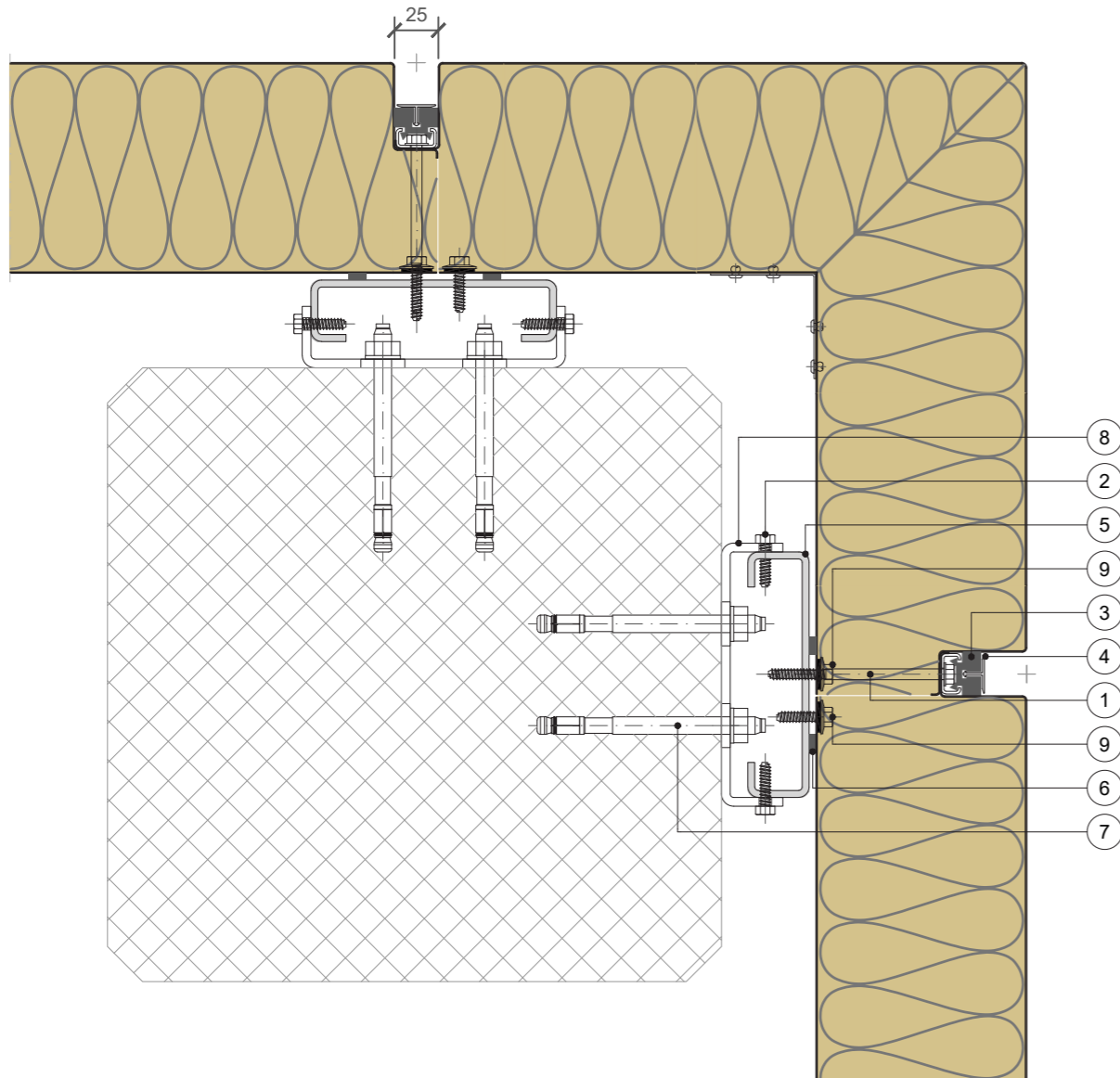

### NOTE

- Direction of installation needs to be specified.
- The detail is suitable for substructure within  $\pm 2$  mm tolerance.

POS.	ELEMENTS	SCALE: M 1:4
1	Fixing screw	
2	Fixing screw	
3	EPDM Transversal gasket	
4	Decorative ALU extrusion	
5	Fast fixing adjustable leveling substructure - supporting	
6	Sealing tape	
7	Anchor bolt	
8	Fast fixing adjustable leveling substructure - load bearing	
9	Fixing screw	

## EXTERNAL CORNER

Trimo Group holds full copyrights on the information and details provided on this media, therefore any unauthorized reproduction and distribution is strictly prohibited.



# E. INSTALLATION GUIDE

## ARCHITECTURAL DETAILS

### 3D DETAIL Q0-H-04.01

**External L corner** detail with horizontally laid corner elements offers a unique façade edge design. Final attachment of façade elements is performed by use of attachment profiles after adjacent elements are in place.

[CAD download centre](#)

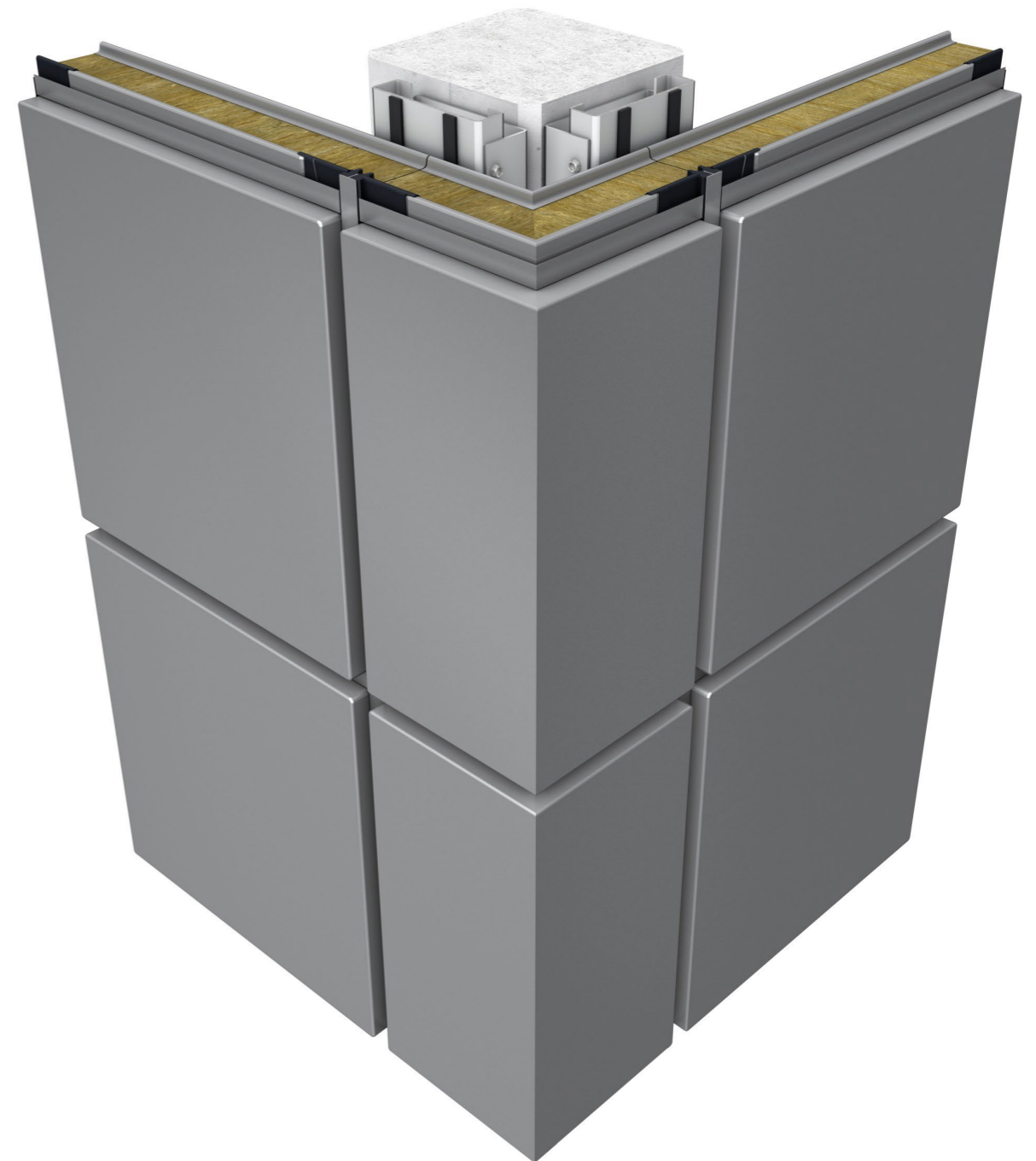



# HORIZONTAL INSTALLATION

## QBISS ONE

### JOINT TYPE

- B - B     BF - BF
- B - BF     F - B
- BF - B     F - BF

### BUILDING APPLICATION

- External Facade     External Soffit
- Internal Wall     Internal Ceiling

HORIZONTAL CUT

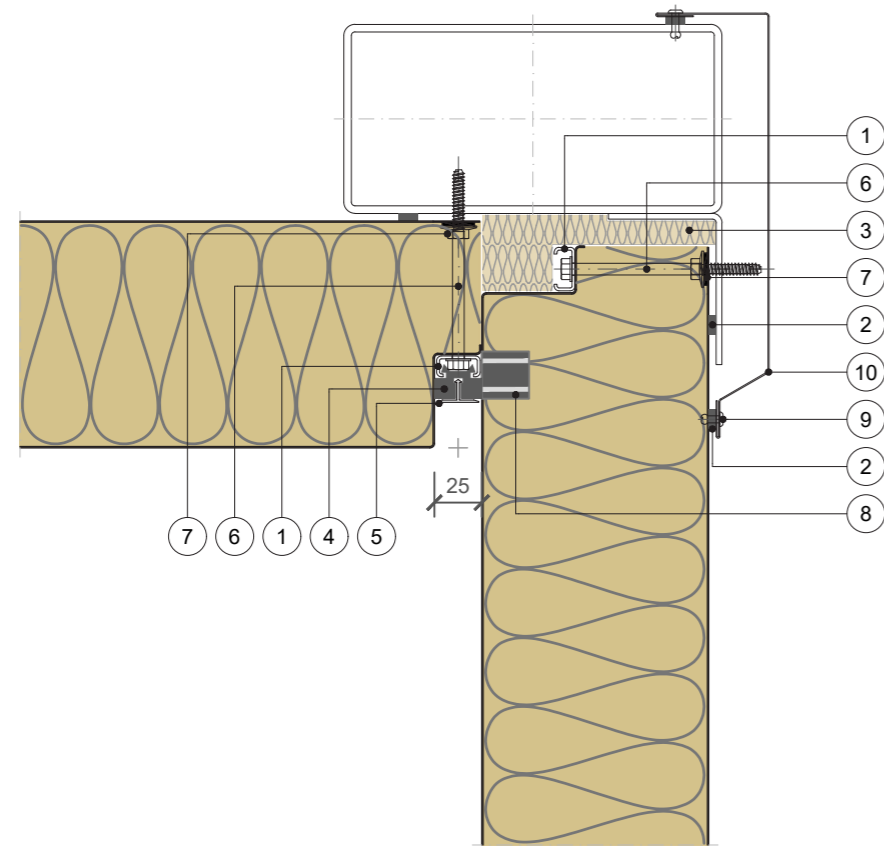

### NOTE

- Direction of installation needs to be specified.
- The detail is suitable for substructure within  $\pm 2$  mm tolerance.
- Adjustable substructure to be used when tolerances are out of range.

POS.	ELEMENTS	SCALE: M 1:4
1	Load bearing fixing plate	
2	Sealing tape	
3	Insulation - MW	
4	EPDM Transversal gasket	
5	Decorative ALU extrusion	
6	Fixing screw	
7	Fixing screw	
8	EPDM cube gasket	
9	Blind rivet	
10	Corner flashing - inner	

## INTERNAL CORNER

Trimo Group holds full copyrights on the information and details provided on this media, therefore any unauthorized reproduction and distribution is strictly prohibited.



## E. INSTALLATION GUIDE

# ARCHITECTURAL DETAILS

### 3D DETAIL Q0-H-05.01

**Internal corner** detail with horizontally laid Qbiss One elements offers a unique façade edge design. Sealing of a longitudinal joint is performed by using a square gasket.

[CAD download centre](#)

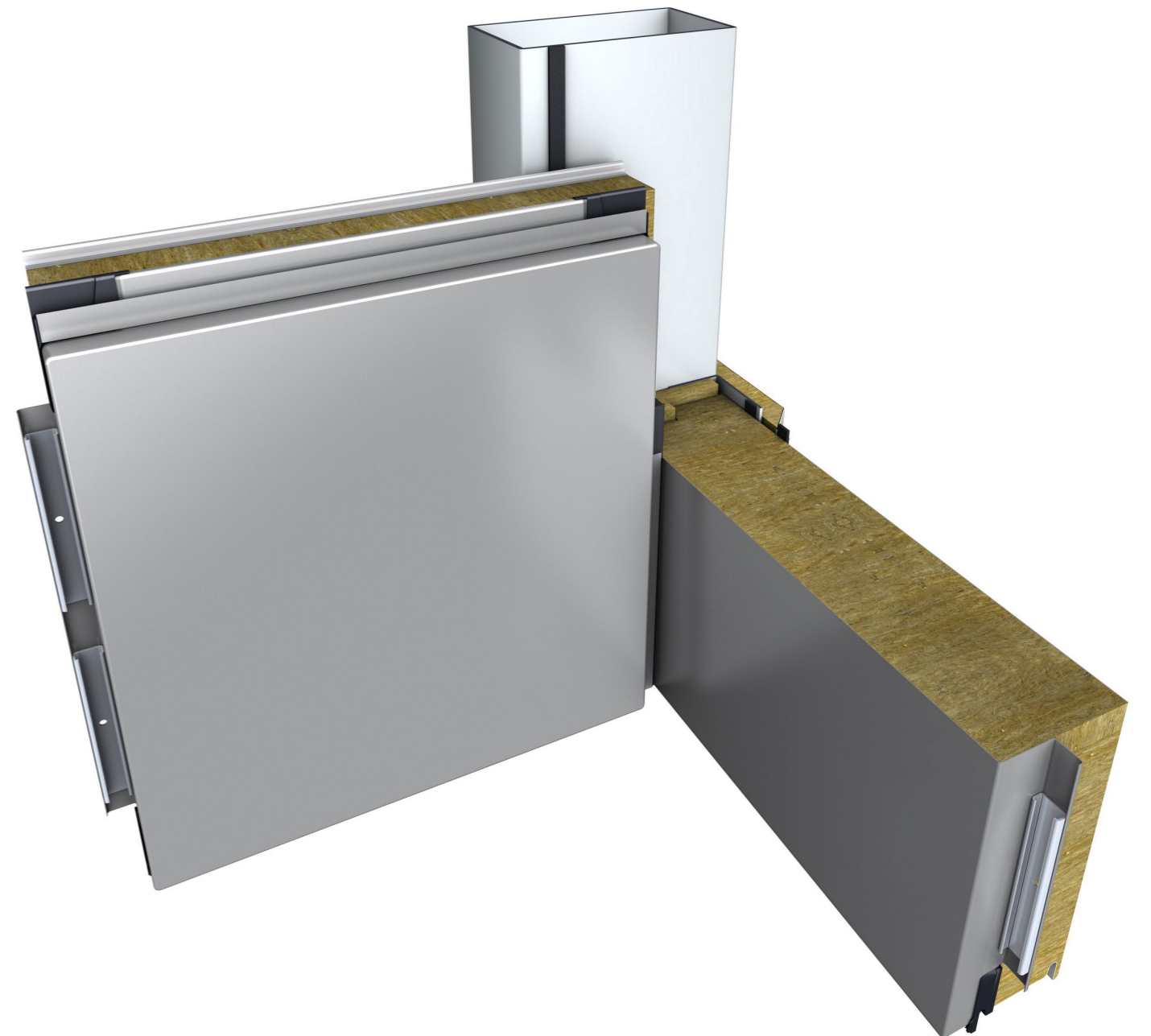



# HORIZONTAL INSTALLATION

## QBISS ONE

### JOINT TYPE

- B - B
- B - BF
- BF - B
- BF - BF
- F - B
- F - BF

### BUILDING APPLICATION

- External Façade
- External Soffit
- Internal Wall
- Internal Ceiling

### HORIZONTAL CUT

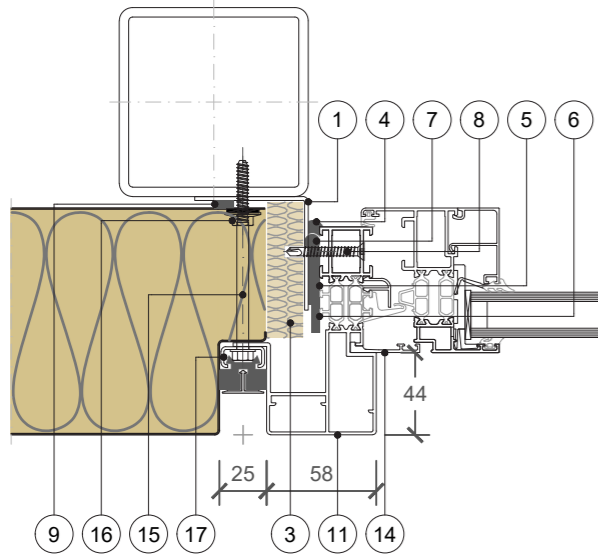

### VERTICAL CUT

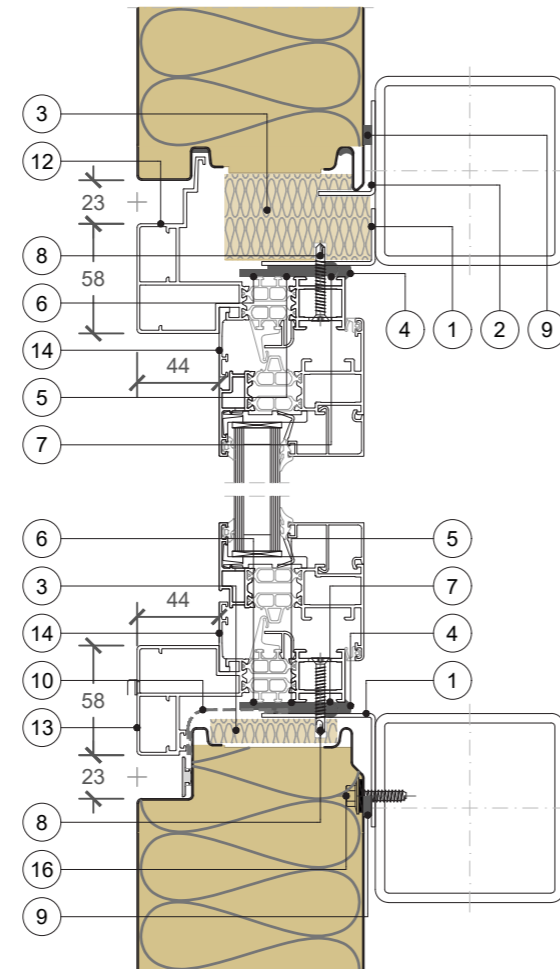

### NOTE

- The detail does not include window sash and associated seals.
- When window frame is longer than 6,5m a dilatation element is necessary.
- Seals and sashes are available at an additional cost. Glazing seals are in domain of the glass supplier.
- Direction of installation needs to be specified.
- The detail is suitable for substructure within  $\pm 2$  mm tolerance.

POS.	ELEMENTS	SCALE: M 1:4
1	Support frame	
2	Cladding element holder	
3	Insulation - MW	
4	Mastic sealant	
5	Insulation foam	
6	Sealing tape	
7	Sealing tape rounded	
8	Fixing screw	
9	Sealing tape	
10	Alu-butyl tape	
11	Window frame - cross joint - HF21	
12	Window frame - upper - HF16	
13	Window frame - bottom - HF17	
14	Outer glass fixing element - HF22	
15	Fixing screw	
16	Fixing screw	
17	Load bearing fixing plate	

## WINDOW

Trimo Group holds full copyrights on the information and details provided on this media, therefore any unauthorized reproduction and distribution is strictly prohibited.



## E. INSTALLATION GUIDE

# ARCHITECTURAL DETAILS

### 3D DETAIL Q0-H-06.01

**Window** detail can be finished quickly and by repeating action. Details must be in compliance with simultaneous installation of the window and façade elements. Windows can be delivered to the site assembled or disassembled.

[CAD download centre](#)

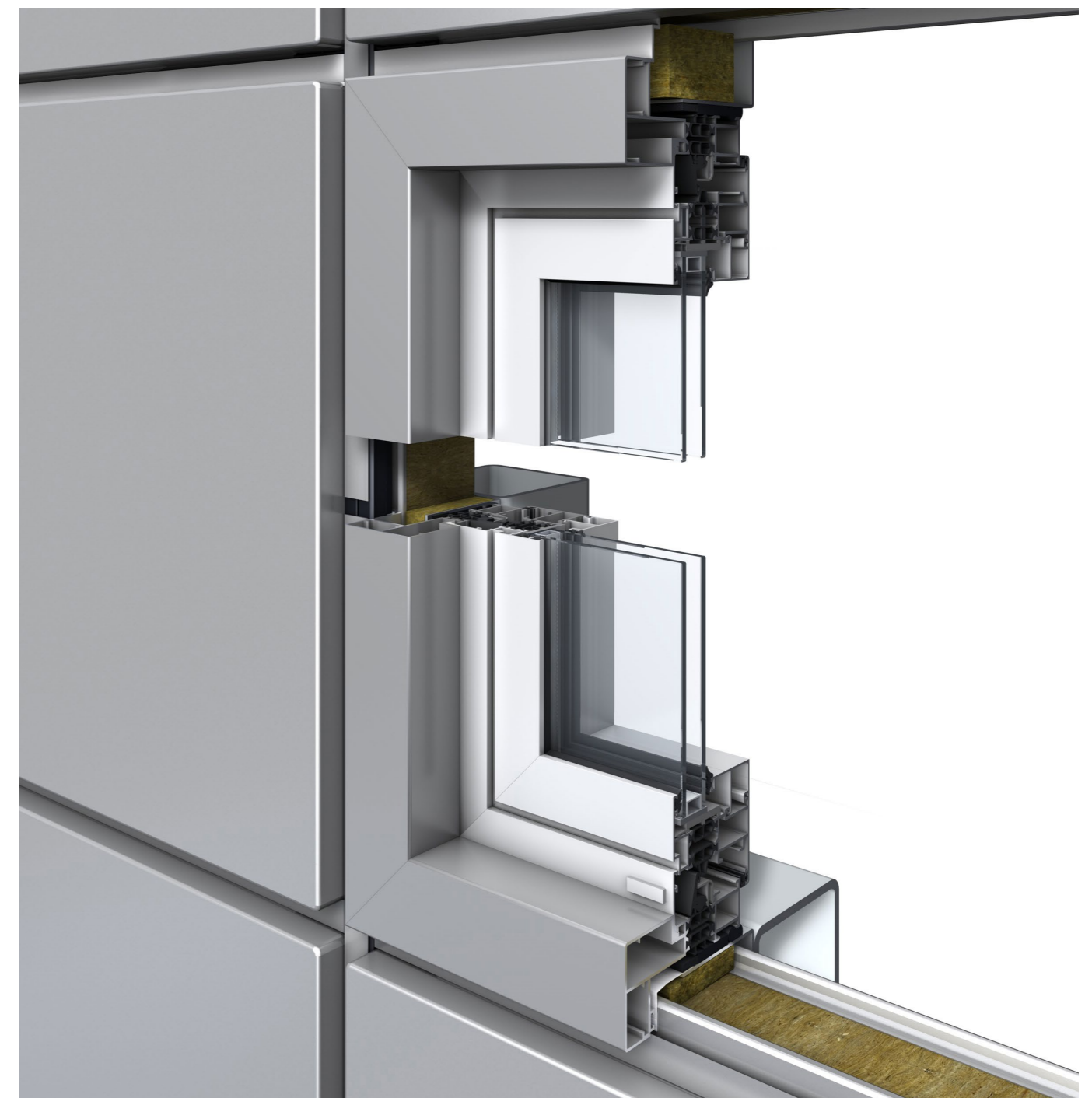



# HORIZONTAL INSTALLATION

## QBISS ONE

### JOINT TYPE

- B - B    ○ BF - BF
- B - BF    ○ F - B
- BF - B    ○ F - BF

### BUILDING APPLICATION

- External Facade    ○ External Soffit
- Internal Wall    ○ Internal Ceiling

VERTICAL CUT

HORIZONTAL CUT

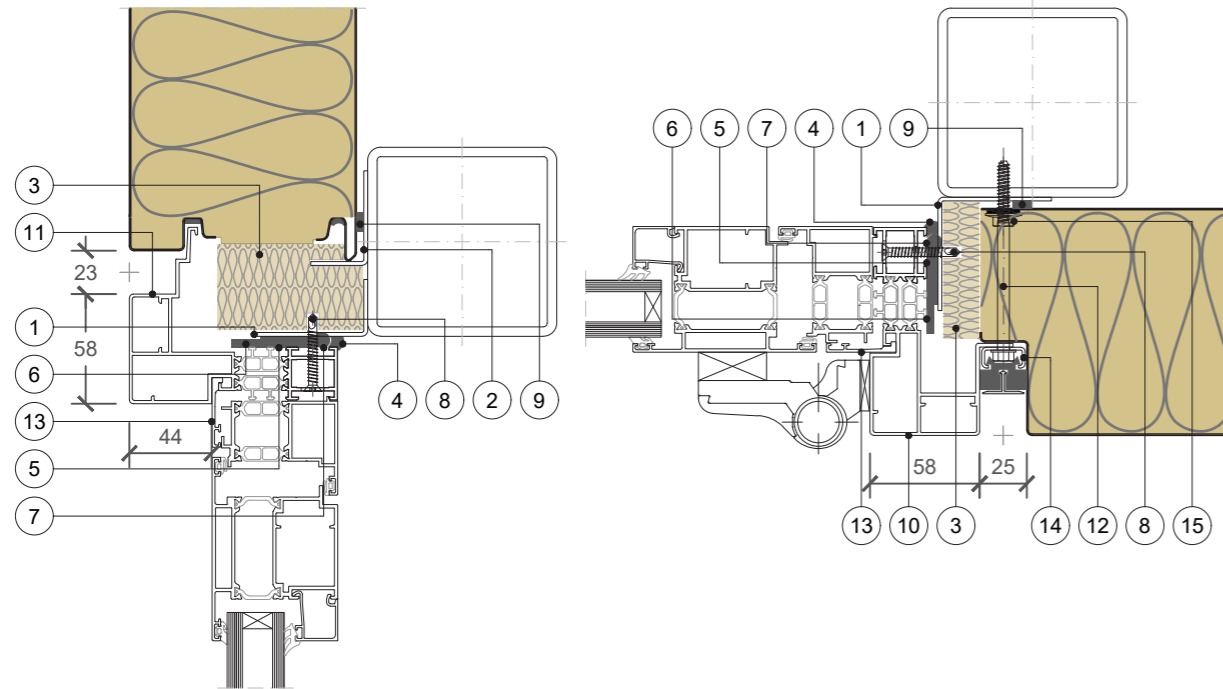

### NOTE

- The detail does not include door sash and associated seals.
- When door frame is longer than 6,5m a dilatation element is necessary.
- Seals and sashes are available at an additional cost. Glazing seals in domain of the glass supplier.
- Direction of installation needs to be specified.
- The detail is suitable for substructure within  $\pm 2$  mm tolerance.

POS.	ELEMENTS	SCALE: M 1:4
1	Support frame	
2	Cladding element holder	
3	Insulation - MW	
4	Mastic sealant	
5	Insulation foam	
6	Sealing tape	
7	Sealing tape rounded	
8	Fixing screw	
9	Sealing tape	
10	Door frame - cross joint - HF21	
11	Door frame - upper - HF16	
12	Fixing screw	
13	Outer glass fixing element - HF22	
14	Load bearing fixing plate	
15	Fixing screw	

## DOOR

Trimo Group holds full copyrights on the information and details provided on this media, therefore any unauthorized reproduction and distribution is strictly prohibited.



# E. INSTALLATION GUIDE

## ARCHITECTURAL DETAILS

### 3D DETAIL Q0-H-07.01

**Door** detail can be finished quickly and by repeating action. Details must be in compliance with simultaneous installation of door and façade elements. Doors can be delivered to the site assembled or disassembled.

[CAD download centre](#)







# HORIZONTAL INSTALLATION

## QBISS ONE

### JOINT TYPE

- B - B     BF - BF
- B - BF     F - B
- BF - B     F - BF

### BUILDING APPLICATION

- External Facade     External Soffit
- Internal Wall     Internal Ceiling

HORIZONTAL CUT

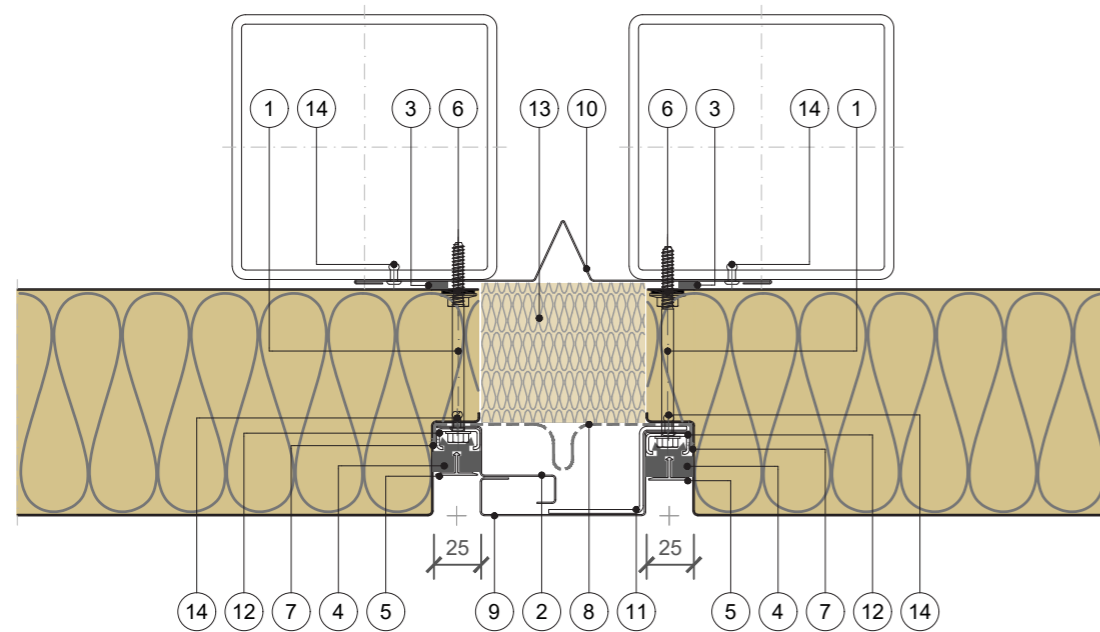

### NOTE

- Maximum dilatation allowed  $\pm 25$  mm.
- Direction of installation needs to be specified.
- The detail is suitable for substructure within  $\pm 2$  mm tolerance.
- Adjustable substructure to be used when tolerances are out of range.

POS.	ELEMENTS	SCALE: M 1:4
1	Fixing screw	
2	Dilatation flashing - intermediate	
3	Sealing tape	
4	EPDM Transversal gasket	
5	Decorative ALU extrusion	
6	Fixing screw	
7	EPDM membrane glue	
8	EPDM membrane	
9	Dilatation flashing - external	
10	Dilatation flashing - internal	
11	Z profile	
12	Load bearing fixing plate	
13	Insulation - MW	
14	Blind rivet	



## E. INSTALLATION GUIDE

# ARCHITECTURAL DETAILS

3D DETAIL Q0-H-09.01

**Dilatation** detail enables compensation of expansion/shrinking of long façades and buildings for façades longer than 50 m.

[CAD download centre](#)

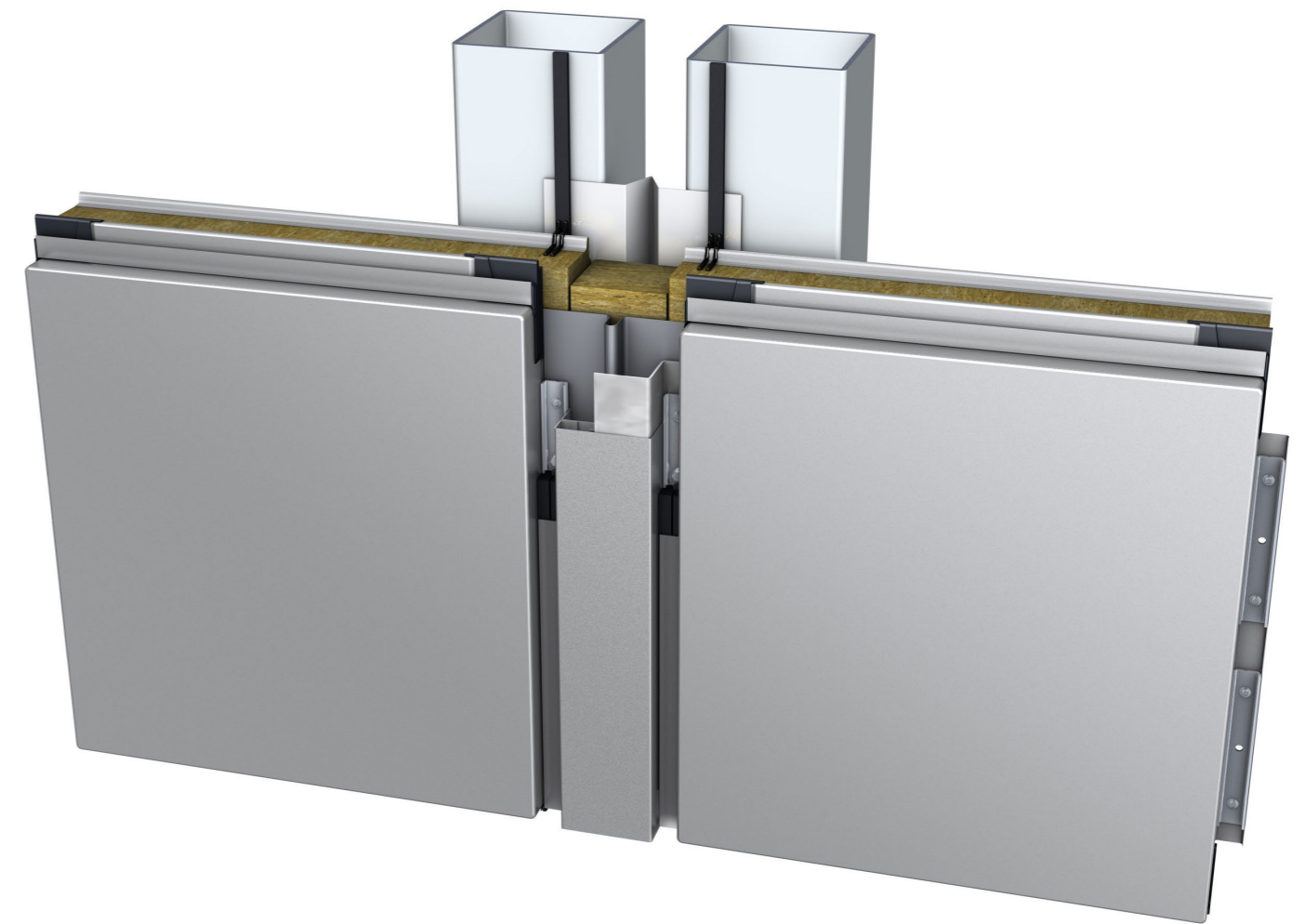



# HORIZONTAL INSTALLATION

## QBISS ONE

### JOINT TYPE

- B - B     BF - BF
- B - BF     F - B
- BF - B     F - BF

### BUILDING APPLICATION

- External Façade     External Soffit
- Internal Wall     Internal Ceiling

HORIZONTAL CUT

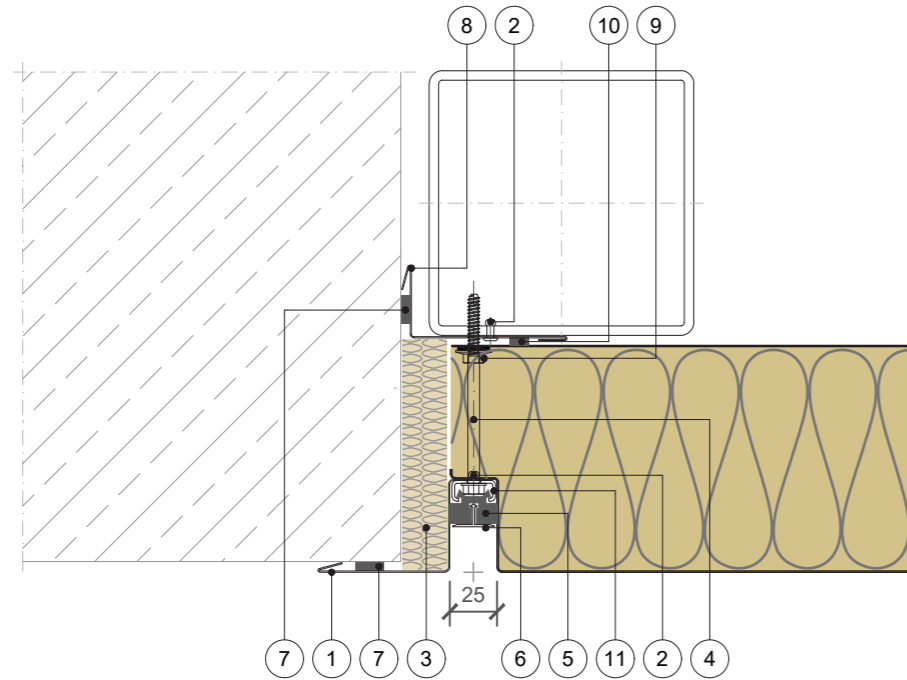

### NOTE

- Installation direction is optional.
- The detail is suitable for substructure within  $\pm 2$  mm tolerance.
- Adjustable substructure to be used when tolerances are out of range.

POS.	ELEMENTS	SCALE: M 1:4
1	Flashing	
2	Blind rivet	
3	Insulation - MW	
4	Fixing screw	
5	EPDM Transversal gasket	
6	Decorative ALU extrusion	
7	Sealing tape	
8	Corner flashing	
9	Fixing screw	
10	Sealing tape	
11	Load bearing fixing plate	

## OTHER SYSTEM CONNECTION

Trimo Group holds full copyrights on the information and details provided on this media, therefore any unauthorized reproduction and distribution is strictly prohibited.



## E. INSTALLATION GUIDE

# ARCHITECTURAL DETAILS

### 3D DETAIL Q0-H-11.01

**Other system connection** detail with horizontally laid corner elements offers a unique façade connection to any other standard, concrete or brickwork façade available on the market. Space between two façade systems is sealed and filled with additional thermal insulation.

[CAD download centre](#)

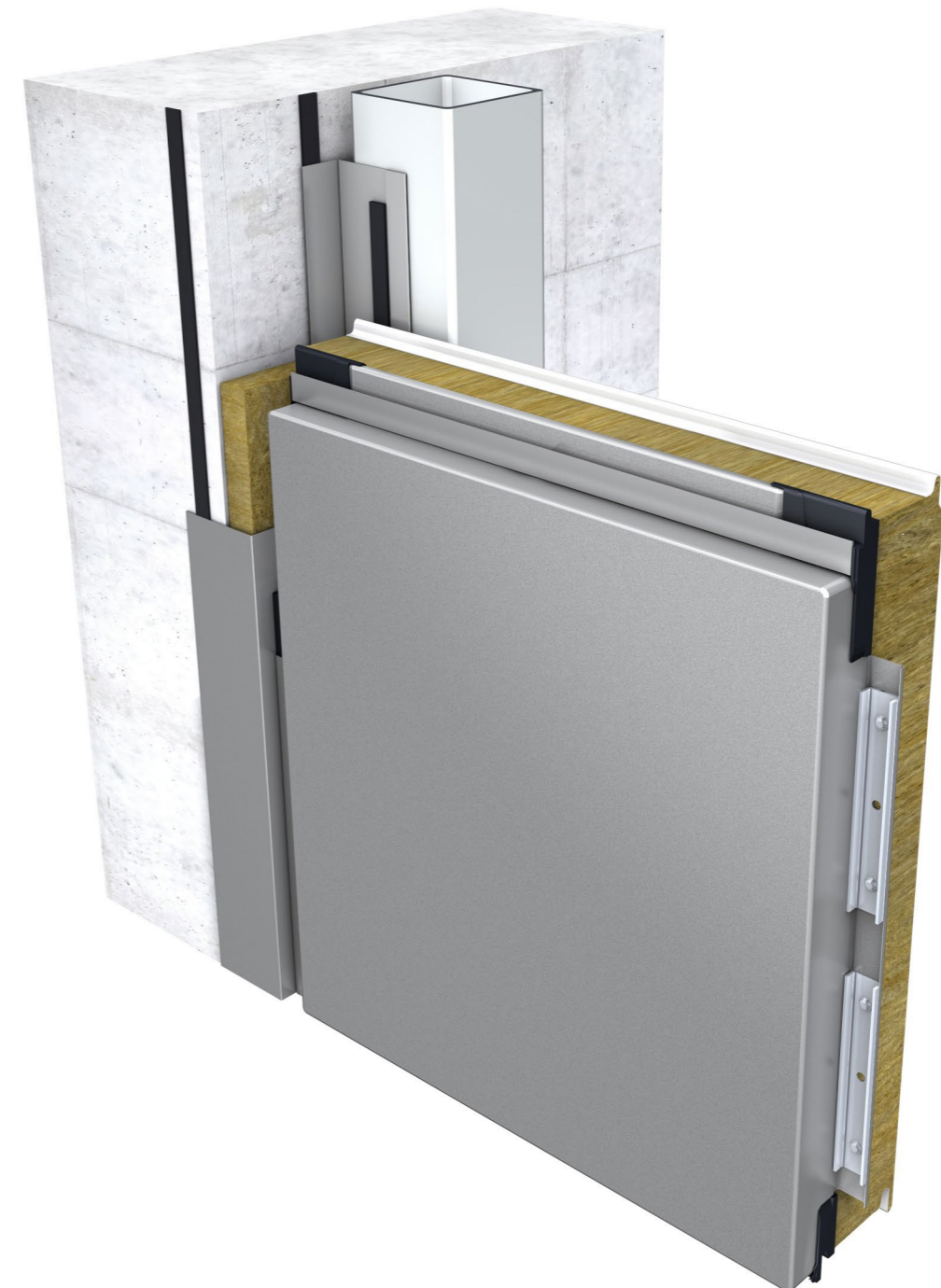



## E. INSTALLATION GUIDE

# ARCHITECTURAL DETAILS



### VERTICAL DETAILS OVERVIEW

Architectural details not only increase design efficiency, but shorten the design process. They ensure the stunning appearance of the building with more than 500 different typical details available. Architectural details on this media are selected out of standard Qbiss One vertical details. If default element setting is changed, installation procedure might vary.

#### Documentation download centre

-  [CAD download centre](#)
-  [BIM download centre](#)
-  [Installation videos channel](#)

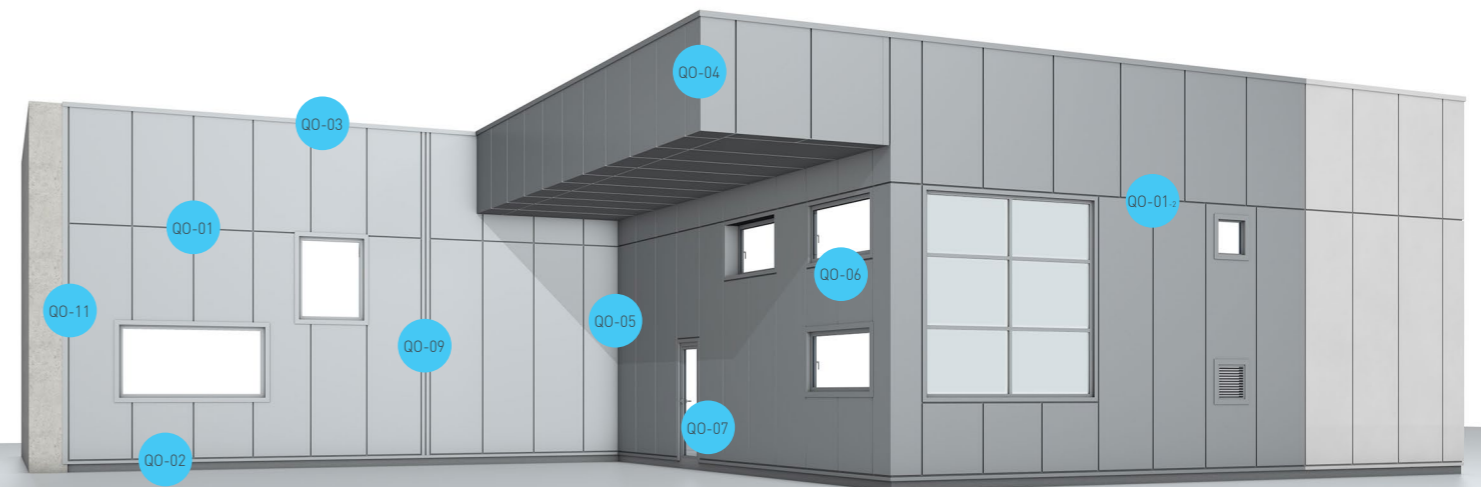



# VERTICAL INSTALLATION QBISS ONE

## JOINT TYPE

- B - B     BF - BF
- B - BF     F - B
- BF - B     F - BF

## BUILDING APPLICATION

- External Facade     External Soffit
- Internal Wall     Internal Ceiling

### VERTICAL CUT

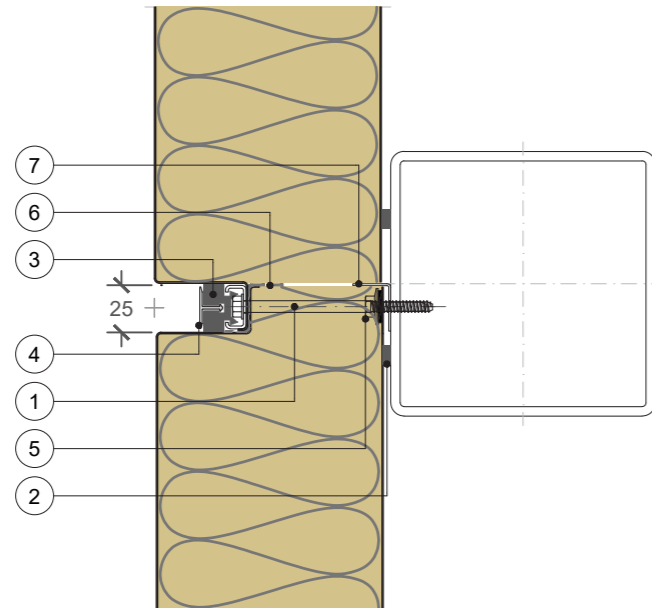

### HORIZONTAL CUT

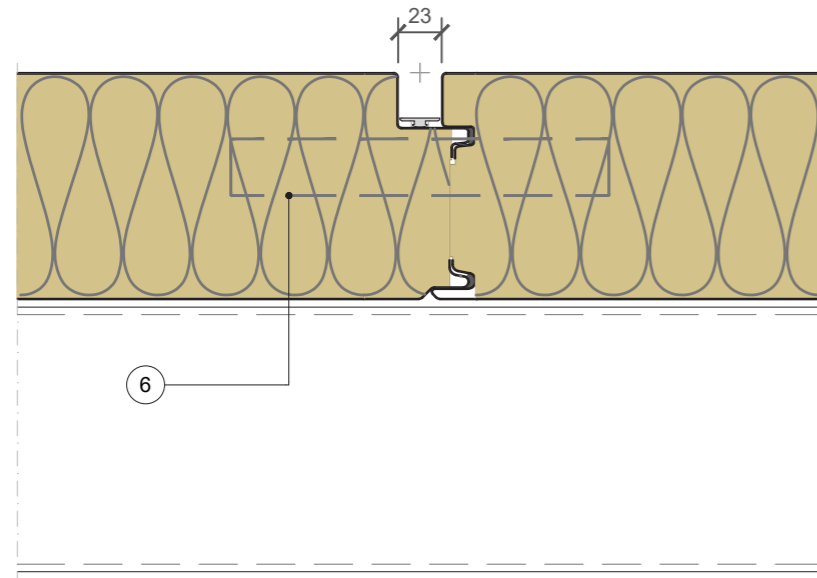

### NOTE

- Direction of installation needs to be specified.
- The detail is suitable for substructure within  $\pm 2$  mm tolerance.
- Adjustable substructure to be used when tolerances are out of range.

POS.	ELEMENTS	SCALE: M 1:4
1	Fixing screw	
2	Sealing tape	
3	EPDM Transversal gasket	
4	Decorative ALU extrusion	
5	Fixing screw	
6	Membrane with glue	
7	Joint profile	

## JOINT

Trimo Group holds full copyrights on the information and details provided on this media, therefore any unauthorized reproduction and distribution is strictly prohibited.



# E. INSTALLATION GUIDE ARCHITECTURAL DETAILS

## 3D DETAIL Q0-V-01.01

**Joint** detail of Qbiss One façade element contains integrated corner gasket as part of Trimo patented sealing system. The sealing of the longitudinal joint is accomplished using a sealing tape, inserted gasket and decorative Alu. extrusion.

[CAD download centre](#)





# VERTICAL INSTALLATION

## QBISS ONE

### JOINT TYPE

- B - B     BF - BF
- B - BF     F - B
- BF - B     F - BF

### BUILDING APPLICATION

- External Façade     External Soffit
- Internal Wall     Internal Ceiling

VERTICAL CUT

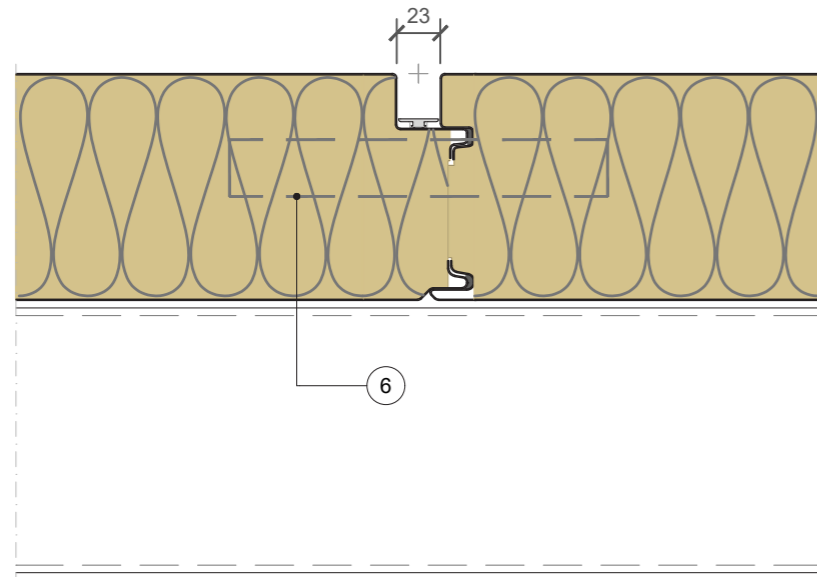

BRICK SYSTEM

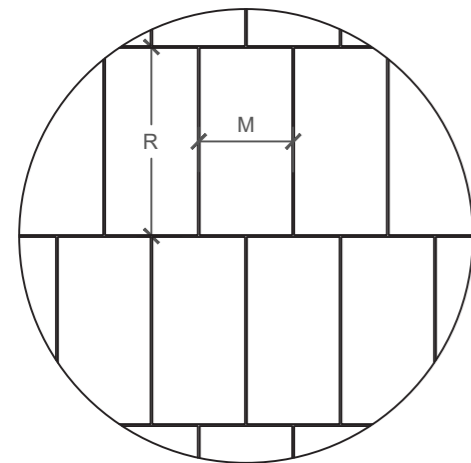

VERTICAL CUT

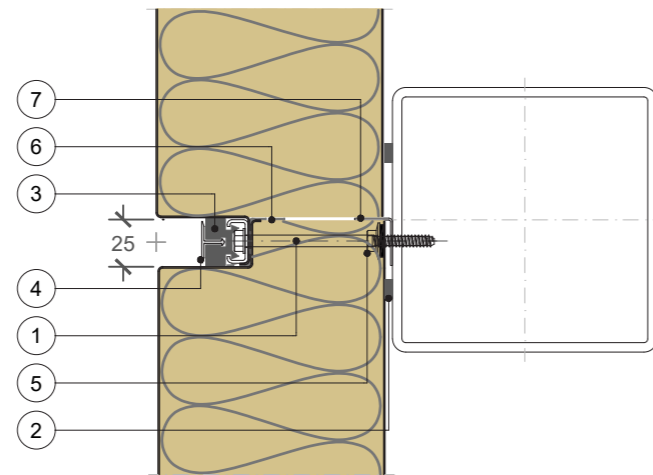

### NOTE

- Direction of installation needs to be specified.
- The detail is suitable for substructure within  $\pm 2$  mm tolerance.
- Adjustable substructure to be used when tolerances are out of range.

POS.	ELEMENTS	SCALE: M 1:4
1	Fixing screw	
2	Sealing tape	
3	EPDM Transversal gasket	
4	Decorative ALU extrusion	
5	Fixing screw	
6	Alu-butyl tape	
7	Joint profile	

## JOINT

Trimo Group holds full copyrights on the information and details provided on this media, therefore any unauthorized reproduction and distribution is strictly prohibited.



# E. INSTALLATION GUIDE

## ARCHITECTURAL DETAILS

### 3D DETAIL Q0-V-01.02

**Brick system** detail enables façade element to be shifted by a portion of the length of the bottom element. For sufficient sealing PE-butyl tape must be applied.

[CAD download centre](#)

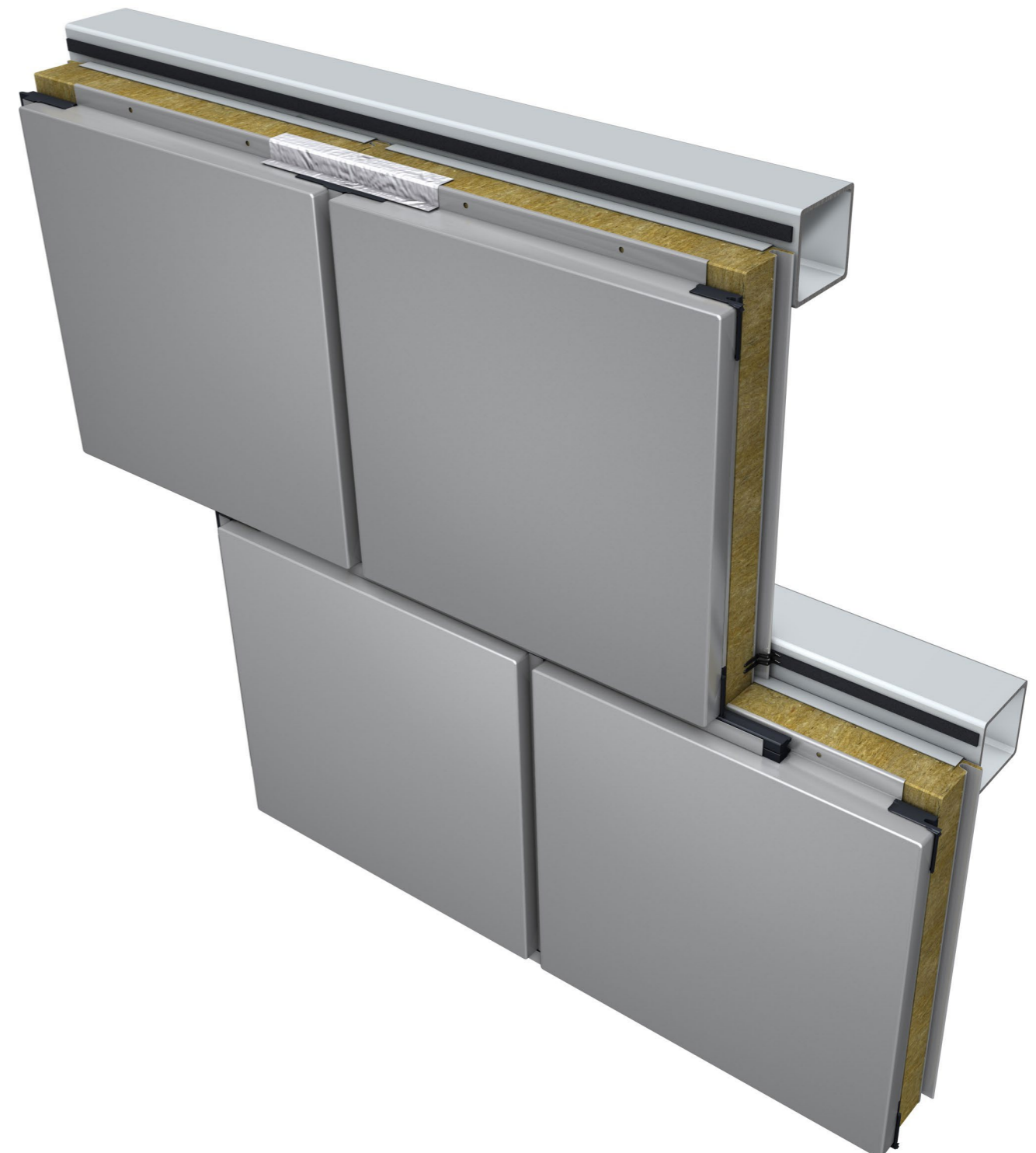



# VERTICAL INSTALLATION QBISS ONE

## JOINT TYPE

- B - B     BF - BF
- B - BF     F - B
- BF - B     F - BF

## BUILDING APPLICATION

- External Facade     External Soffit
- Internal Wall     Internal Ceiling

### VERTICAL CUT

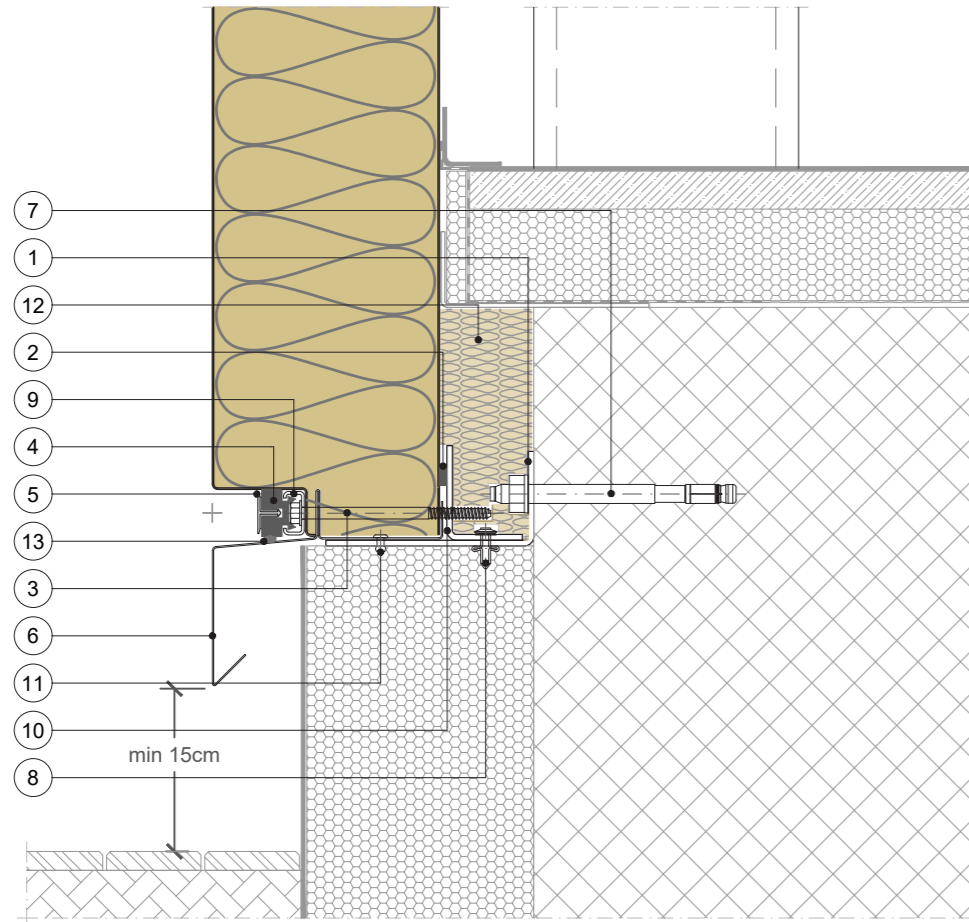

### NOTE

- Direction of installation needs to be specified.
- The detail is suitable for substructure within  $\pm 2$  mm tolerance.
- Adjustable substructure to be used when tolerances are out of range.

POS.	ELEMENTS	SCALE: M 1:4
1	Cladding element holder L profile	
2	Sealing tape	
3	Fixing Screw (with respect to the static calculation)	
4	EPDM Transversal gasket	
5	Decorative ALU extrusion	
6	Drip flashing	
7	Anchor bolt	
8	Bulb tite rivet	
9	Load bearing fixing plate	
10	Cladding element holder L profile	
11	Blind rivet	
12	Insulation - MW	
13	Mastic sealant EPDM	

## BASE

Trimo Group holds full copyrights on the information and details provided on this media, therefore any unauthorized reproduction and distribution is strictly prohibited.



# E. INSTALLATION GUIDE ARCHITECTURAL DETAILS

## 3D DETAIL Q0-V-02.01

**Base system** detail sealing of the longitudinal joint is performed by inserting the EPDM transversal gasket and the decorative profile into the transversal joint.

[CAD download centre](#)

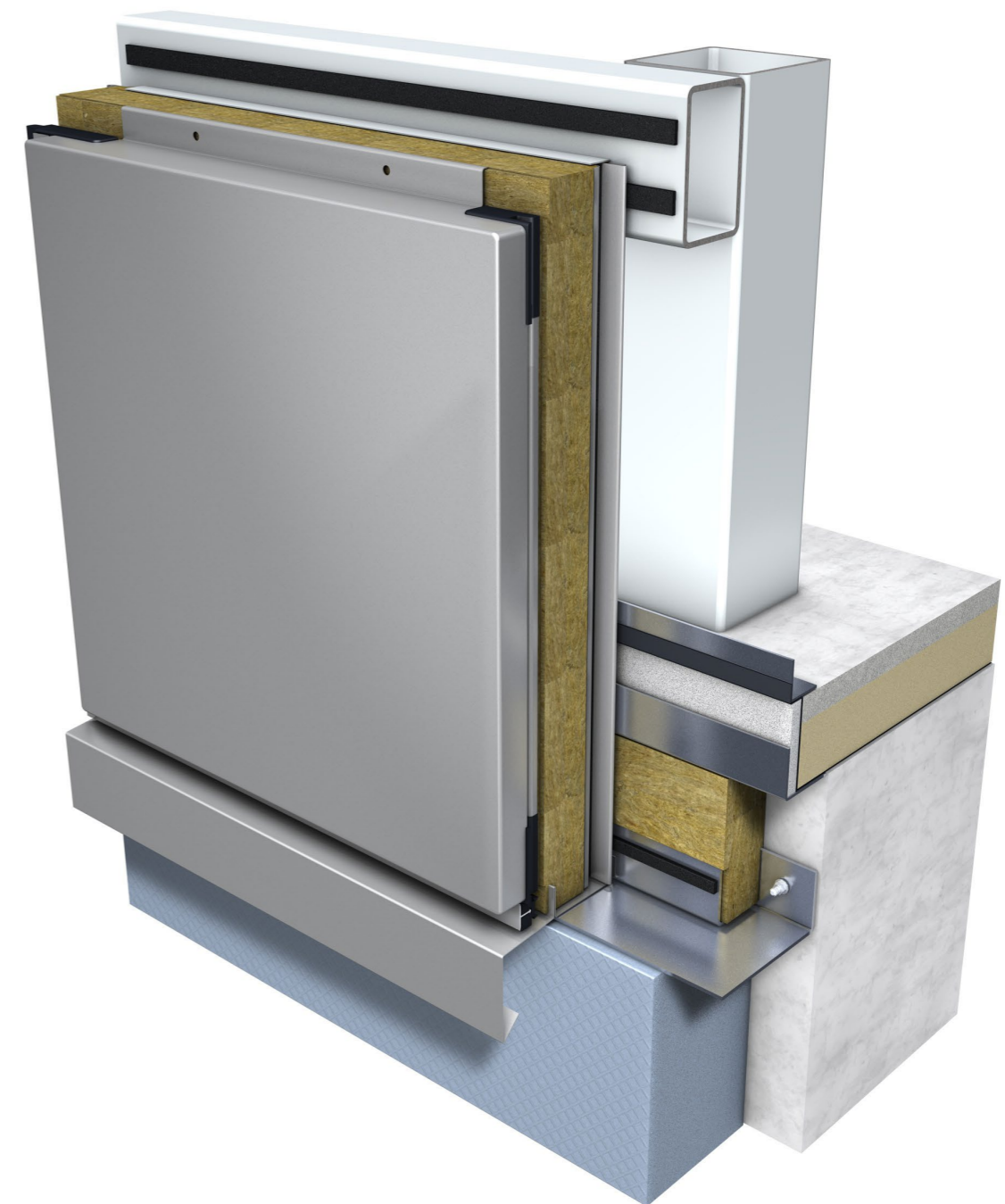



# VERTICAL INSTALLATION QBISS ONE

## JOINT TYPE

- B - B    ○ BF - BF
- B - BF    ○ F - B
- BF - B    ○ F - BF

## BUILDING APPLICATION

- External Facade    ○ External Soffit
- Internal Wall    ○ Internal Ceiling

### VERTICAL CUT

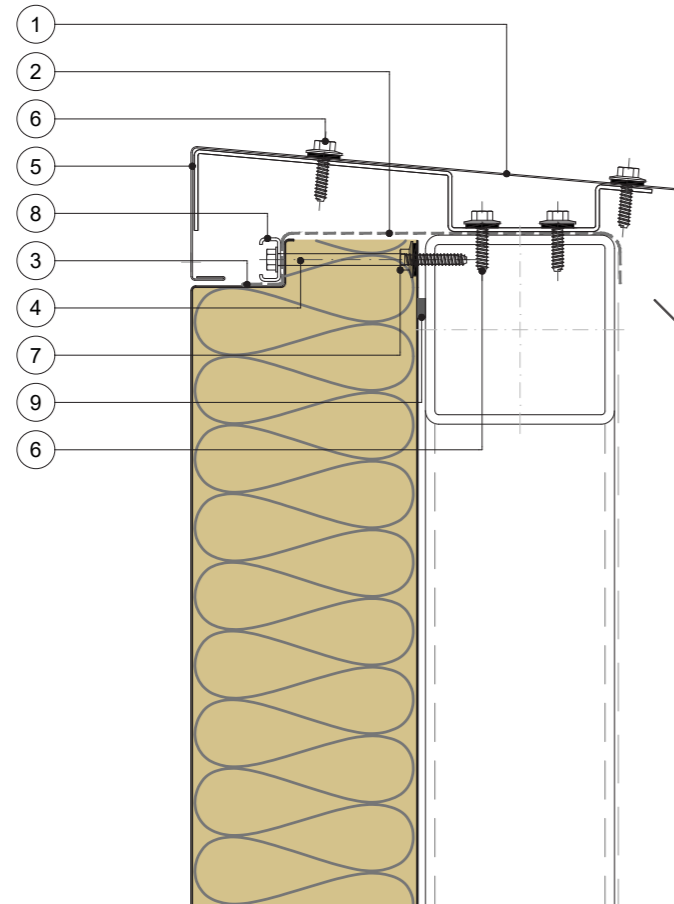

### NOTE

- Direction of installation needs to be specified.
- The detail is suitable for substructure within  $\pm 2$  mm tolerance.
- Adjustable substructure to be used when tolerances are out of range.

POS.	ELEMENTS	SCALE: M 1:4
1	Parapet cap	
2	EPDM membrane	
3	EPDM membrane glue	
4	Fixing screw	
5	Parapet cap support profile	
6	Fixing screw	
7	Fixing screw	
8	Load bearing fixing plate	
9	Sealing tape	

## PARAPET

Trimo Group holds full copyrights on the information and details provided on this media, therefore any unauthorized reproduction and distribution is strictly prohibited.



# E. INSTALLATION GUIDE ARCHITECTURAL DETAILS

## 3D DETAIL Q0-V-03.01

**Parapet** detail finish is performed by using a parapet wall cap. The sealing is performed by finishing joint elements in the longitudinal joint.

[CAD download centre](#)

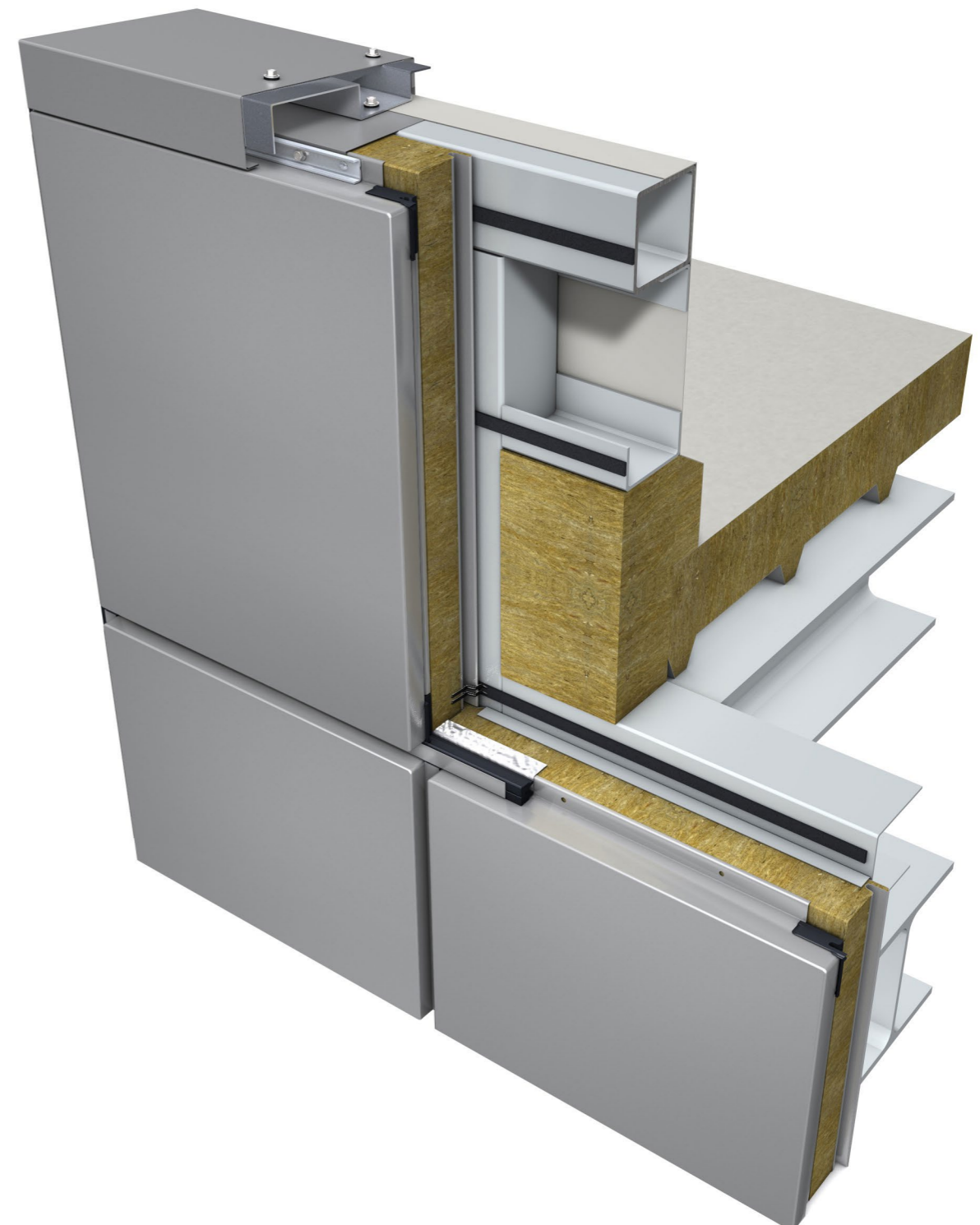



# VERTICAL INSTALLATION

## QBISS ONE

JOINT TYPE		BUILDING APPLICATION	
● B - B	○ BF - BF	● External Facade	○ External Soffit
○ B - BF	○ F - B	○ Internal Wall	○ Internal Ceiling
○ BF - B	○ F - BF		

HORIZONTAL CUT

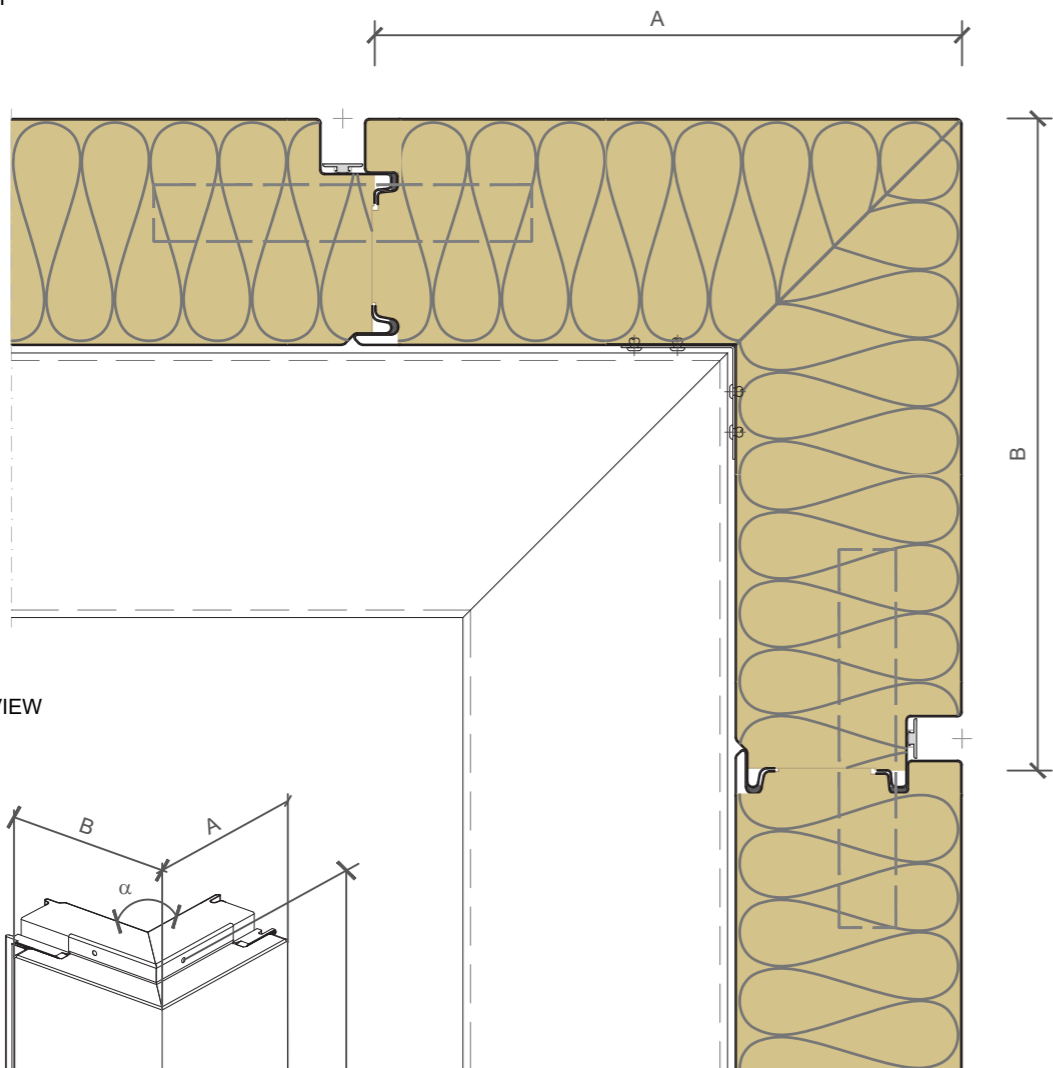

AXONOMETRIC VIEW

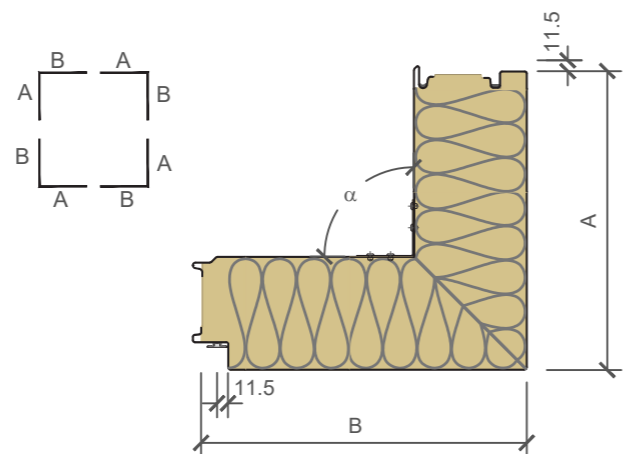
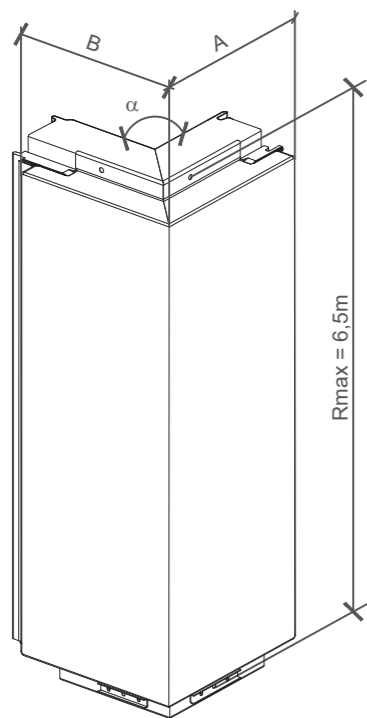

NOTE

- Direction of installation needs to be specified.
- The detail is suitable for substructure within  $\pm 2$  mm tolerance.
- Adjustable substructure to be used when tolerances are out of range.

SCALE: M 1:4

# E. INSTALLATION GUIDE

## ARCHITECTURAL DETAILS



3D DETAIL Q0-V-04.01

**External L corner** detail with vertically laid corner elements offers a unique façade edge design. Final attachment of facade elements is performed by use of attachment profiles after adjacent elements are in place.

[CAD download centre](#)







# VERTICAL INSTALLATION QBISS ONE

## JOINT TYPE

- B - B     BF - BF
- B - BF     F - B
- BF - B     F - BF

## BUILDING APPLICATION

- External Facade     External Soffit
- Internal Wall     Internal Ceiling

### HORIZONTAL CUT

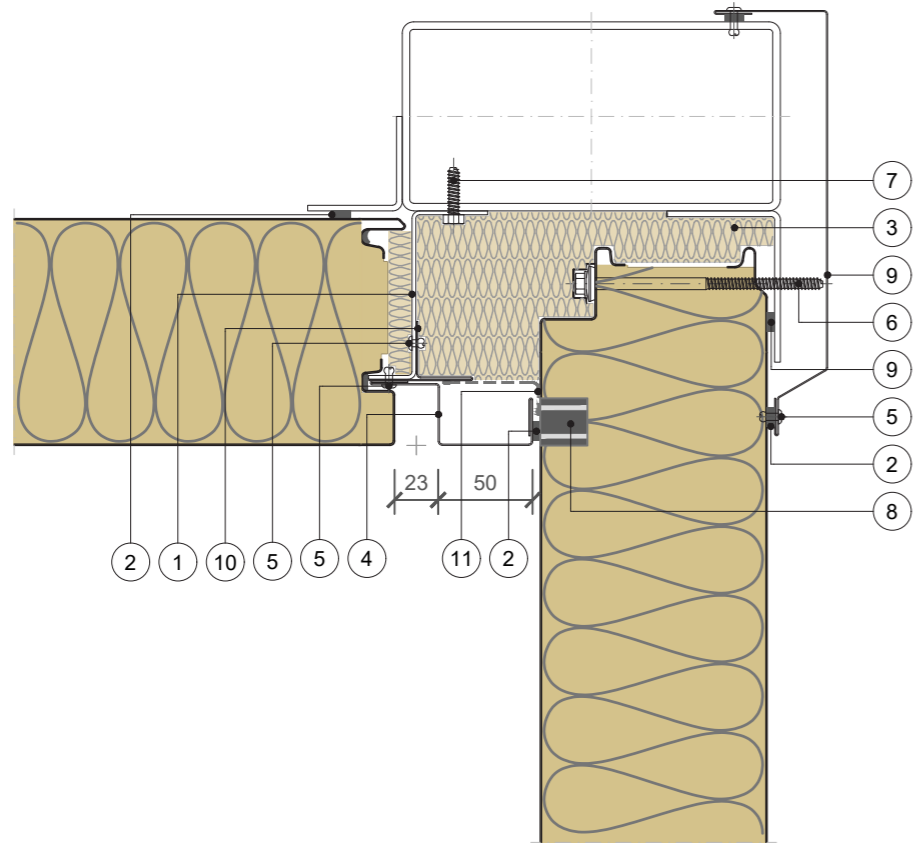

#### NOTE

- Installation direction is optional.
- The detail is suitable for substructure within  $\pm 2$  mm tolerance.
- Adjustable substructure to be used when tolerances are out of range.

POS.	ELEMENTS	SCALE: M 1:4
1	Fixing screw	
2	Sealing tape	
3	Insulation MW	
4	Corner flashing	
5	Blind rivet	
6	Fixing screw	
7	Fixing screw	
8	EPDM cube gasket	
9	Corner flashing Internal	
10	Flashing	
11	EPDM membrane	

## INTERNAL CORNER

Trimo Group holds full copyrights on the information and details provided on this media, therefore any unauthorized reproduction and distribution is strictly prohibited.



# E. INSTALLATION GUIDE ARCHITECTURAL DETAILS

## 3D DETAIL Q0-V-05.01

**Internal corner** detail with vertically laid Qbiss One elements offers a unique façade edge design. Sealing of a transversal joint is performed by using a square gasket.

[CAD download centre](#)

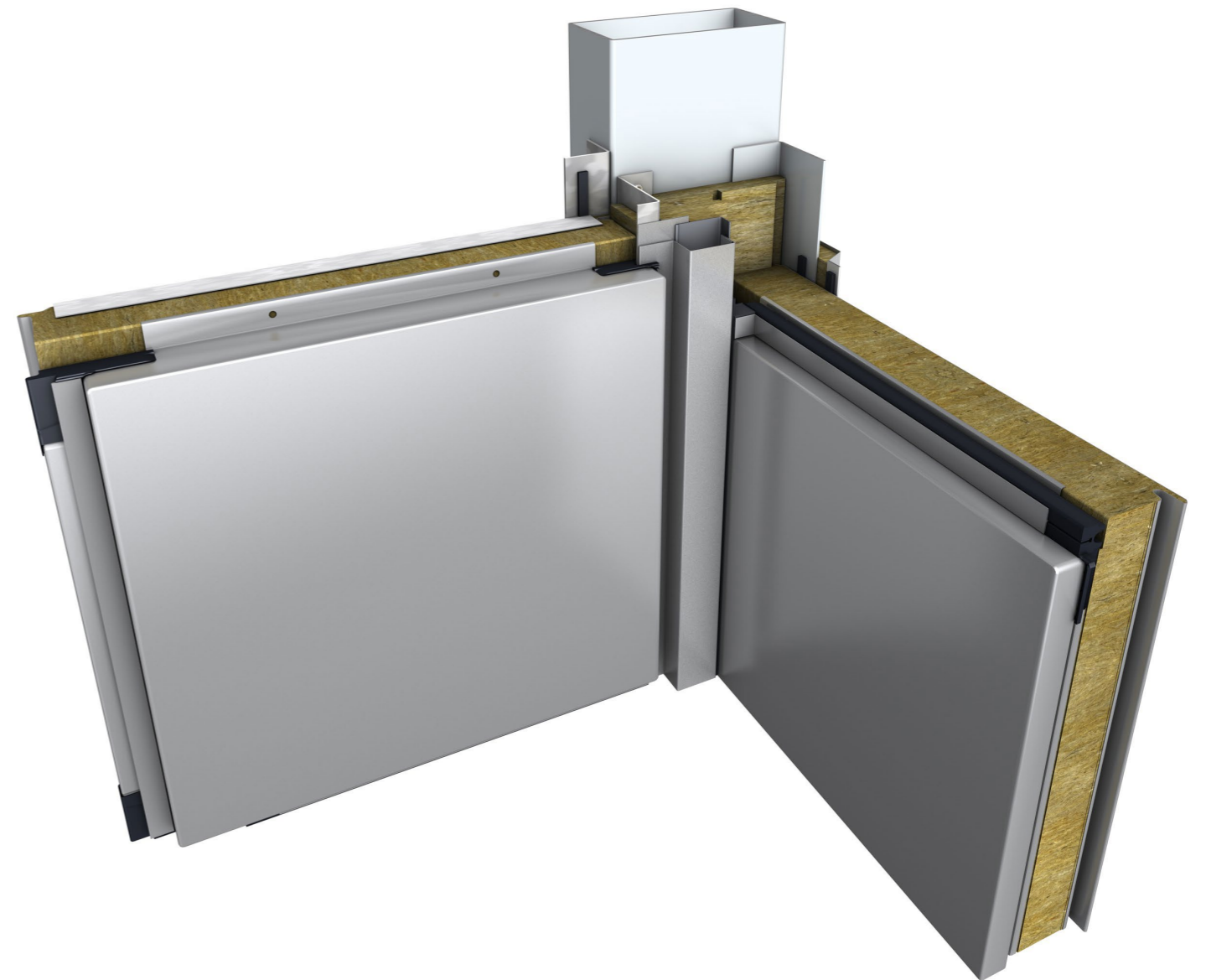



# VERTICAL INSTALLATION QBISS ONE

## JOINT TYPE

- B - B    ○ BF - BF
- B - BF    ○ F - B
- BF - B    ○ F - BF

## BUILDING APPLICATION

- External Facade    ○ External Soffit
- Internal Wall    ○ Internal Ceiling

### VERTICAL CUT

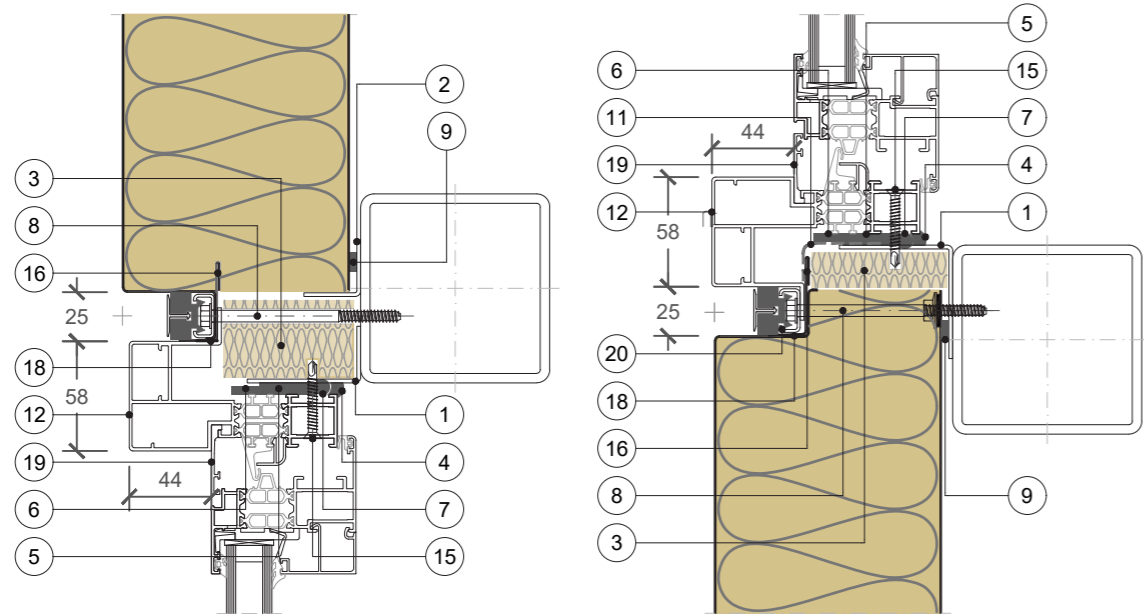

### NOTE

- The detail does not include window sash and associated seals.
- Window frames longer than 6,5 m must be dilatated.
- Seals and sashes are available at an additional cost. Glazing seals are in domain of the glass supplier.
- Direction of installation needs to be specified.
- The detail is suitable for substructure within  $\pm 2$  mm tolerance.
- Adjustable substructure to be used when tolerances are out of range.

POS.	ELEMENTS	SCALE: M 1:4
1	Support frame	
2	Cladding element holder	
3	Insulation - MW	
4	Mastic sealant	
5	Insulation foam	
6	Sealing tape	
7	Rounded PE gasket	
8	Fixing screw	
9	Sealing tape	
10	Alu-butyl tape	
11	Alu-butyl tape	
12	Window Frame Profile - HF21	
13	Window Frame Profile - HF16	
14	Window Frame Profile - HF17	
15	Fixing screw	
16	Flashing	
17	Fixing screw	
18	Mastic sealant EPDM	
19	Outer glass fixing element - HF22	
20	Load bearing fixing plate	



# E. INSTALLATION GUIDE ARCHITECTURAL DETAILS

### DETAIL QO-V-06.01

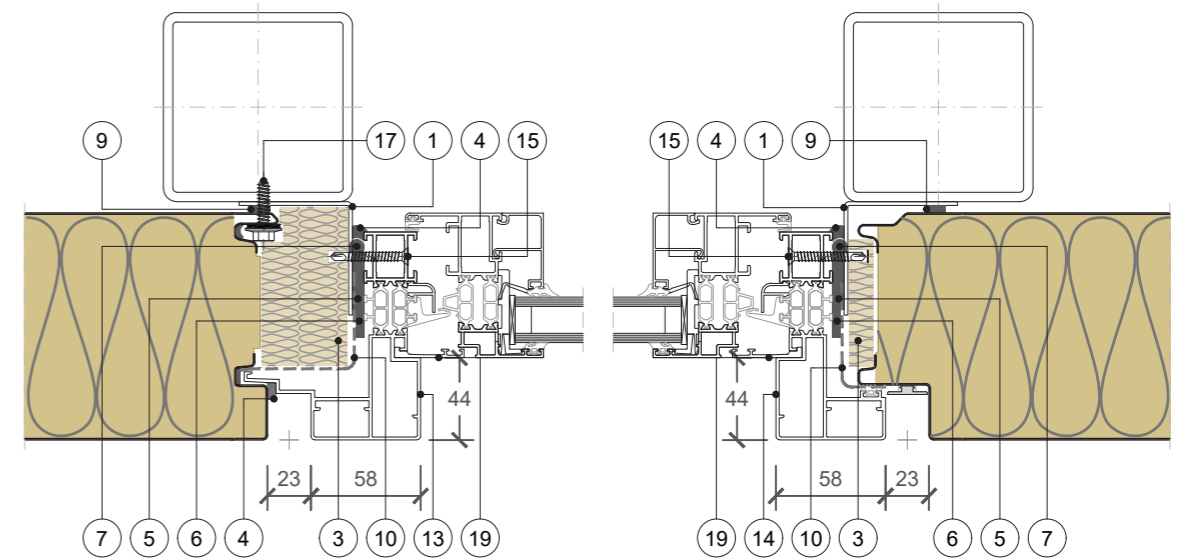

### NOTE

- The detail does not include window sash and associated seals.
- Window frames longer than 6,5 m must be dilatated.
- Seals and sashes are available at an additional cost. Glazing seals are in domain of the glass supplier.
- Direction of installation needs to be specified.
- The detail is suitable for substructure within  $\pm 2$  mm tolerance.
- Adjustable substructure to be used when tolerances are out of range.

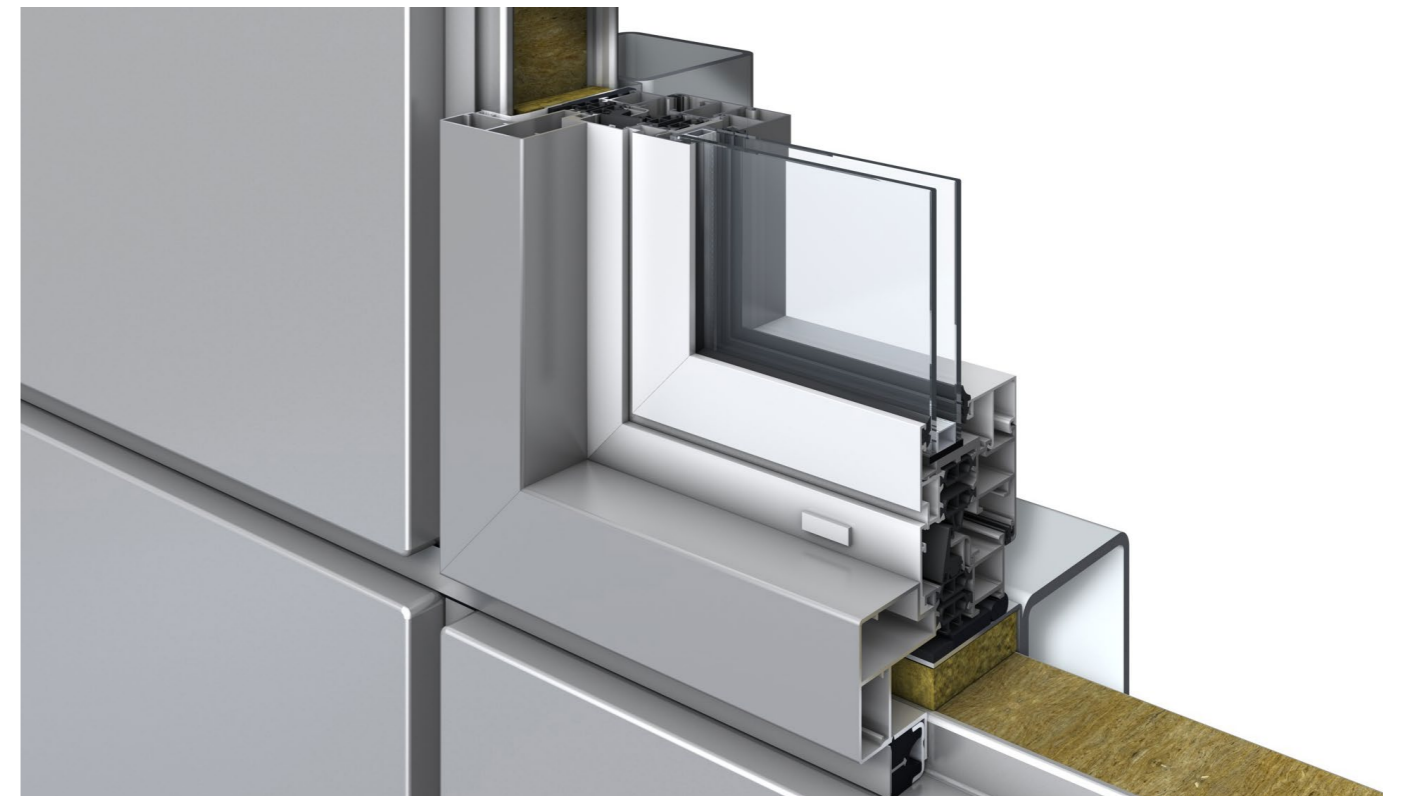



# VERTICAL INSTALLATION QBISS ONE

## JOINT TYPE

- B - B    ○ BF - BF
- B - BF    ○ F - B
- BF - B    ○ F - BF

## BUILDING APPLICATION

- External Facade    ○ External Soffit
- Internal Wall    ○ Internal Ceiling

### VERTICAL CUT

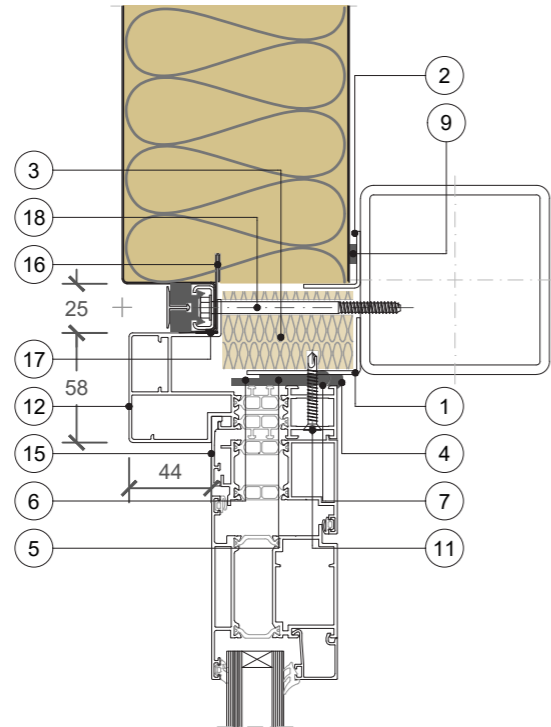

### NOTE

- The detail does not include door sash and associated seals.
- Window frames longer than 6,5 m must be dilatated.
- Seals and sashes are available at an additional cost. Glazing seals are in domain of the glass supplier.
- Direction of installation needs to be specified.
- The detail is suitable for substructure within  $\pm 2$  mm tolerance.
- Adjustable substructure to be used when tolerances are out of range.

POS.	ELEMENTS	SCALE: M 1:4
1	Support frame	
2	Cladding element holder	
3	Thermal Insulation - MW	
4	Mastic sealant	
5	Insulation foam	
6	Sealing tape	
7	Rounded PE gasket	
8	Fixing screw	
9	Sealing tape	
10	Alu-butyl tape	
11	Fixing screw	
12	Door frame profile - HF21	
13	Door frame profile - HF16	
14	Door frame profile-HF17	
15	Outer glass fixing element - HF22	
16	Flashing	
17	Mastic sealant EPDM	
18	Fixing screw	

## DOOR

Trimo Group holds full copyrights on the information and details provided on this media, therefore any unauthorized reproduction and distribution is strictly prohibited.



# E. INSTALLATION GUIDE ARCHITECTURAL DETAILS

## 3D DETAIL Q0-V-07.01

**Door** detail is finished quickly and by repeated action. Details must follow simultaneous installation of door and façade elements.

[CAD download centre](#)

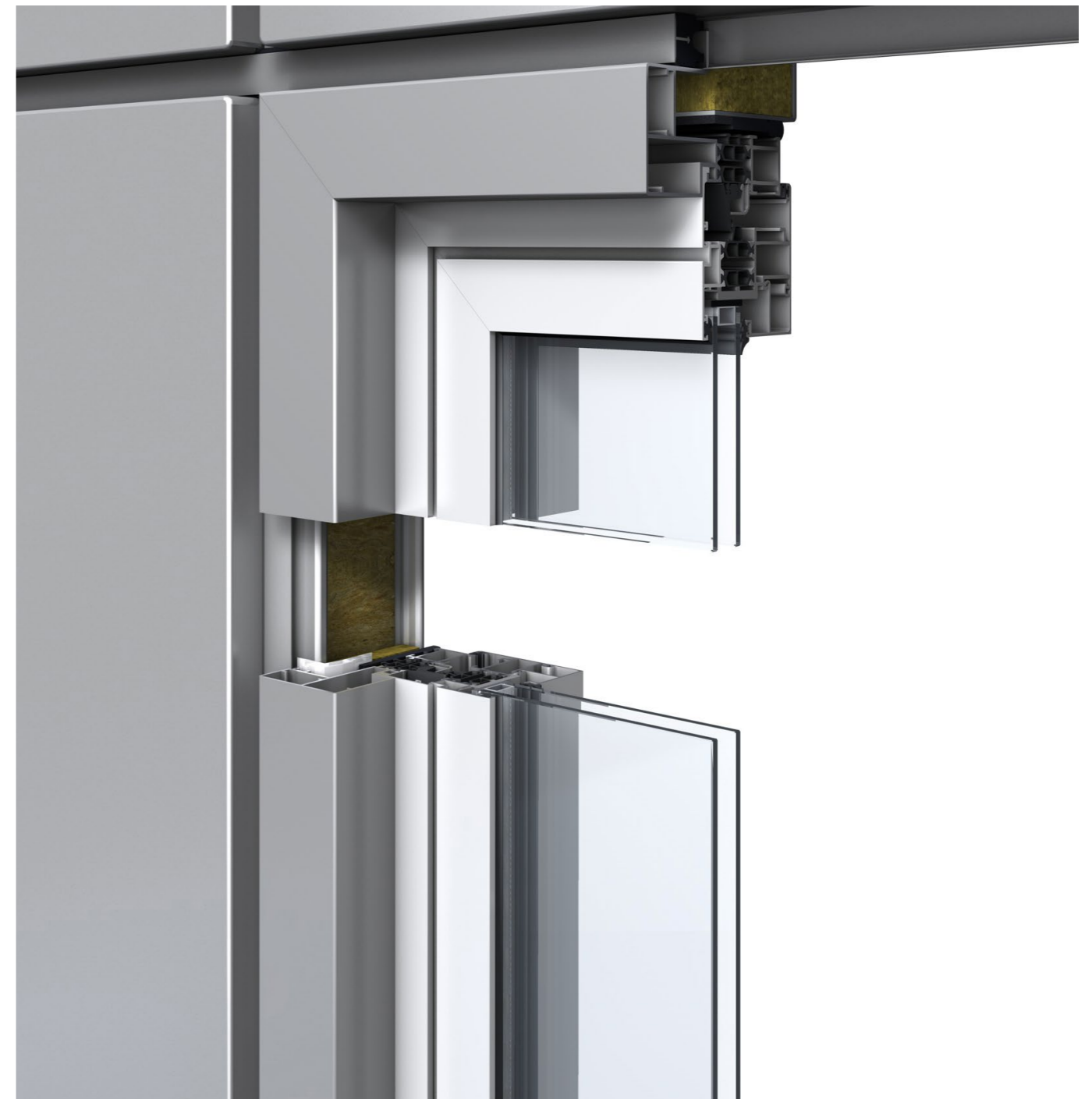



# VERTICAL INSTALLATION

## QBISS ONE

### JOINT TYPE

- B - B
- B - BF
- BF - B
- BF - BF
- F - B
- F - BF

### BUILDING APPLICATION

- External Facade
- External Soffit
- Internal Wall
- Internal Ceiling

HORIZONTAL CUT

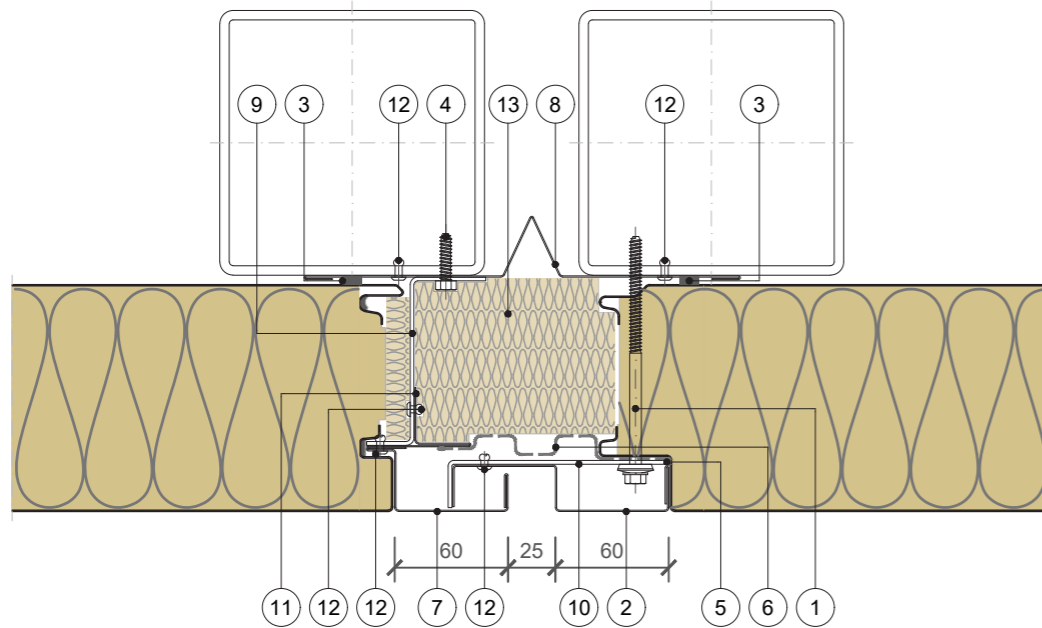

### NOTE

- Maximum dilatation allowed  $\pm 25$  mm.
- Direction of installation needs to be specified.
- The detail is suitable for substructure within  $\pm 2$  mm tolerance.
- Adjustable substructure to be used when tolerances are out of range.

POS.	ELEMENTS	SCALE: M 1:4
1	Fixing screw	
2	Dilatation flashing - intermediate	
3	Sealing tape	
4	Fixing screw	
5	EPDM membrane	
6	EPDM membrane glue	
7	Dilatation flashing - external	
8	Dilatation flashing - internal	
9	Z profile	
10	L profile	
11	Flashing	
12	Blind rivet	
13	Insulation - MW	

## DILATATION

Trimo Group holds full copyrights on the information and details provided on this media, therefore any unauthorized reproduction and distribution is strictly prohibited.



# E. INSTALLATION GUIDE

## ARCHITECTURAL DETAILS

### 3D DETAIL Q0-V-09.01

**Dilatation** detail enables compensation of expansion/shrinking of long façades and buildings for façades longer than 50 m.

[CAD download centre](#)

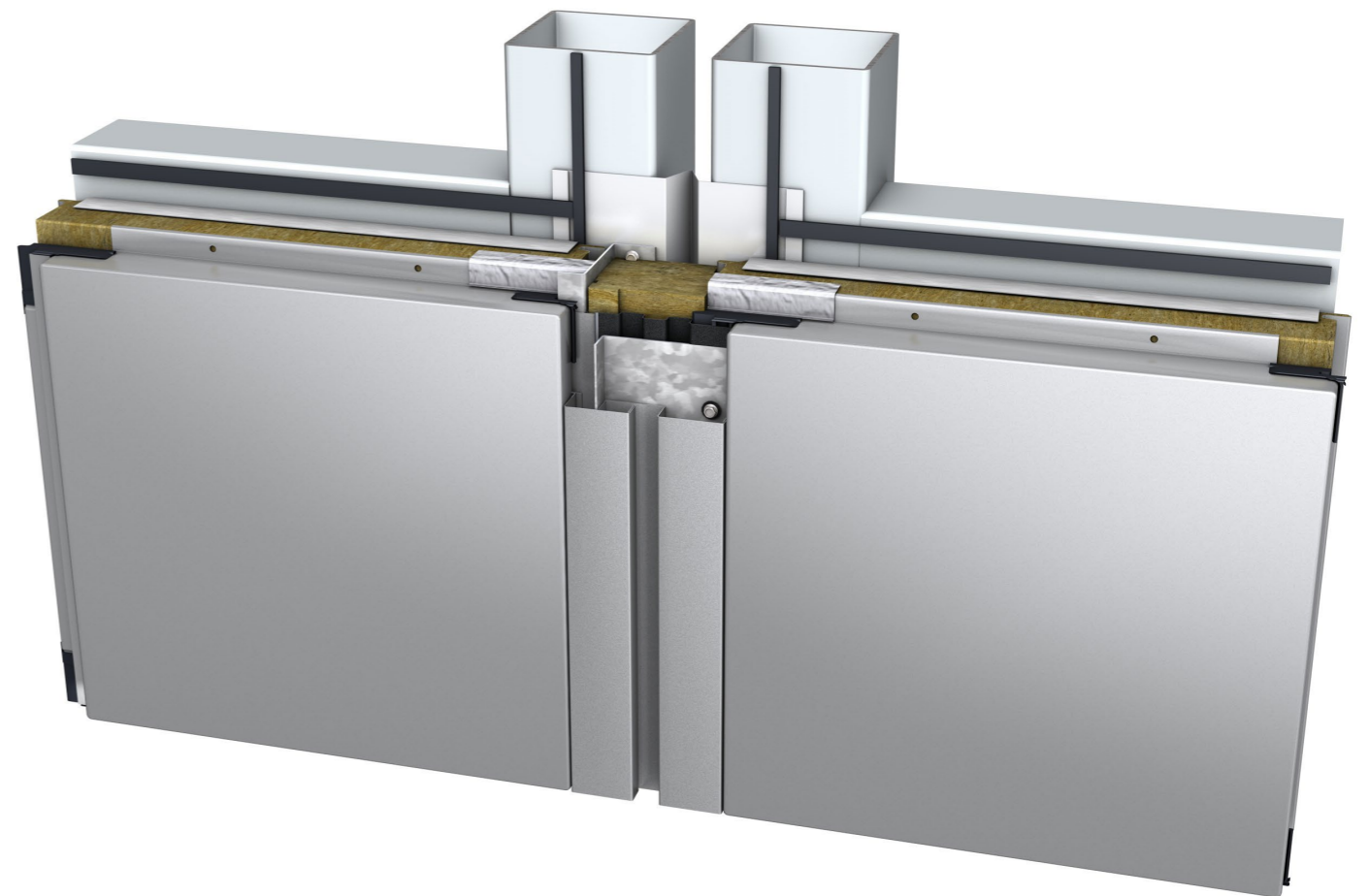



# VERTICAL INSTALLATION QBISS ONE

## JOINT TYPE

- B - B     BF - BF
- B - BF     F - B
- BF - B     F - BF

## BUILDING APPLICATION

- External Façade     External Soffit
- Internal Wall     Internal Ceiling

HORIZONTAL CUT

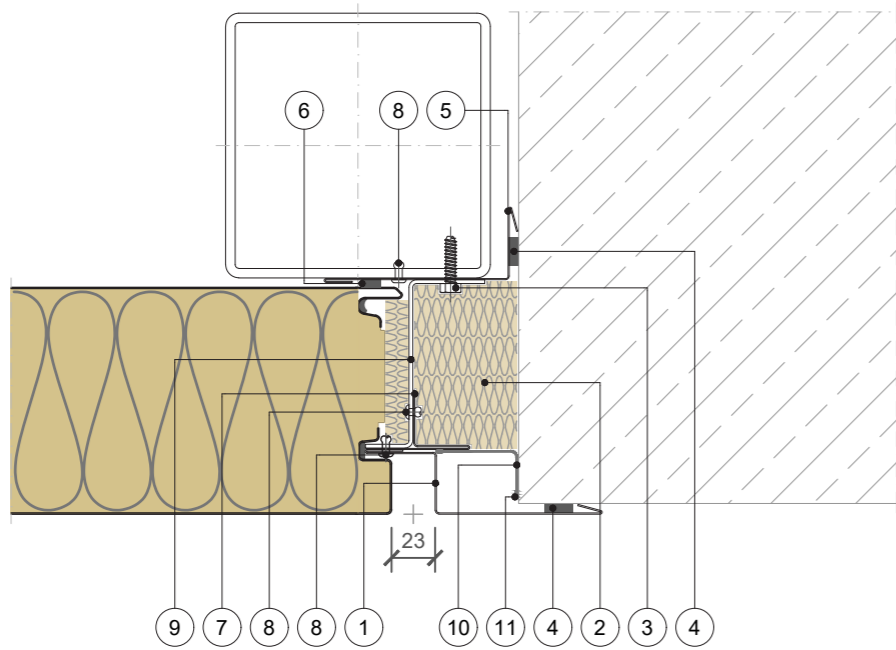

### NOTE

- Direction of installation needs to be specified.
- The detail is suitable for substructure within  $\pm 2$  mm tolerance.
- Adjustable substructure to be used when tolerances are out of range.

POS.	ELEMENTS	SCALE: M 1:4
1	Flashing	
2	Insulation - MW	
3	Fixing screw	
4	Sealing tape EPDM	
5	Internal flashing	
6	Sealing tape	
7	Flashing	
8	Blind rivet	
9	Z profile	
10	EPDM membrane	
11	EPDM membrane glue	

## OTHER SYSTEM CONNECTION

Trimo Group holds full copyrights on the information and details provided on this media, therefore any unauthorized reproduction and distribution is strictly prohibited.



# E. INSTALLATION GUIDE ARCHITECTURAL DETAILS

## 3D DETAIL Q0-V-11.01

**Other system connection** detail with vertically laid elements offers a unique façade connection to any other standard, concrete or brickwork façade available on the market. Space between two façade systems is sealed and filled with additional thermal insulation.

[CAD download centre](#)



# HORIZONTAL INSTALLATION DETAILS

## INSTALLATION NOTES - STEP 1

**NOTES / Wear protective gloves and clothing when handling sharp elements, edges and corners. Before installation work, check whether the installation site is subject to any particular requirements regarding occupational safety. Always follow the local occupational safety provisions.**

A geodetic scan to check the level of the support structure is highly recommended. If it does not fit within permissible tolerances, fast fixing adjustable levelling substructure must be used. The substructure can be adjusted by  $\pm 25$  mm. The supporting profile must be aligned with Qbiss One façade element support's on the main structure.

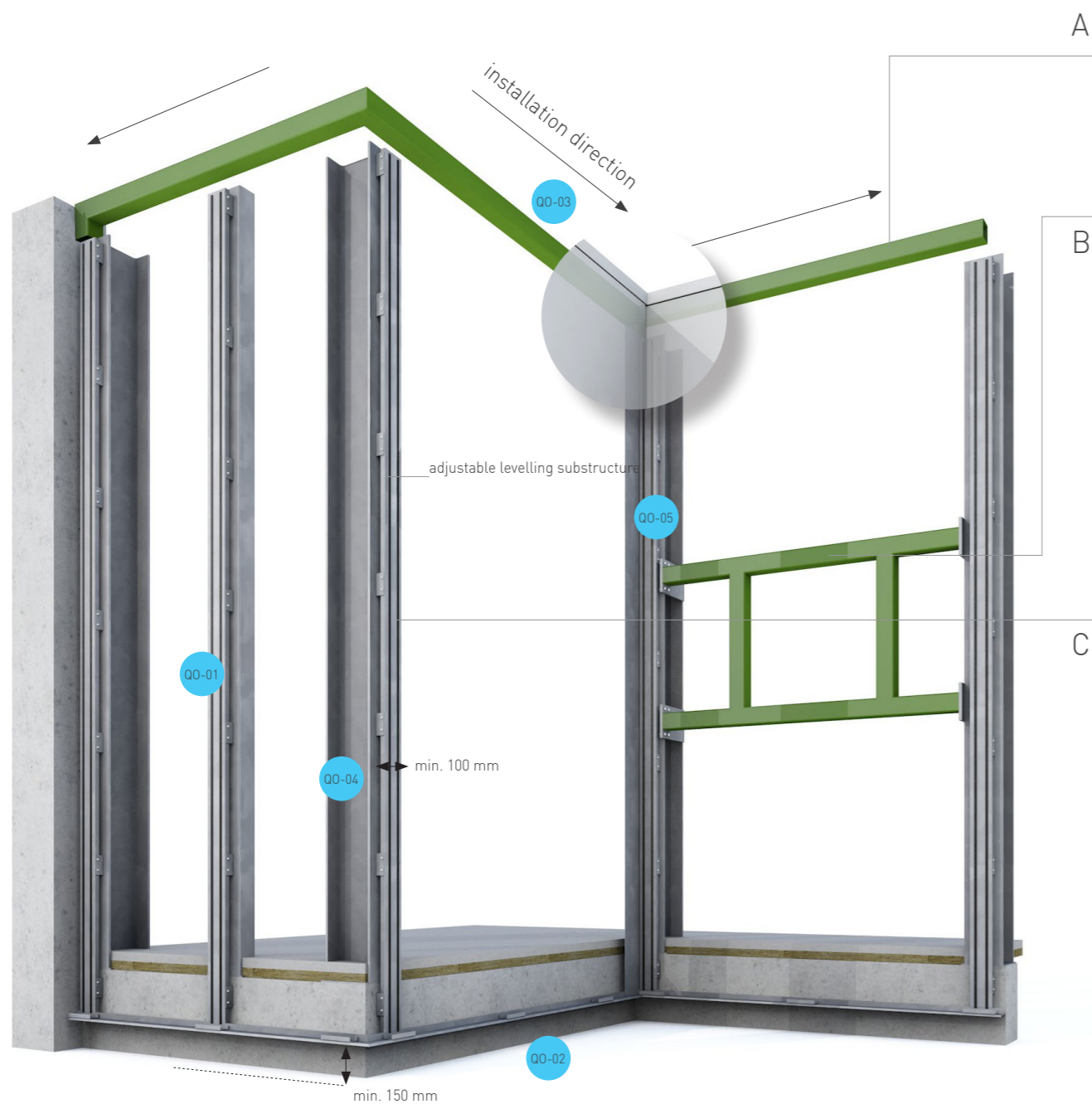

## ADJUSTABLE LEVELLING SUBSTRUCTURE 3D DETAIL

- 1 Contact surface levelling profile (fixed with self-tapping screws)
- 2 Self-tapping screw
- 3 Support frames
- 4 Sealing tape
- 5 Concrete column
- 6 Qbiss One façade element

[🌐 CAD download centre](#)

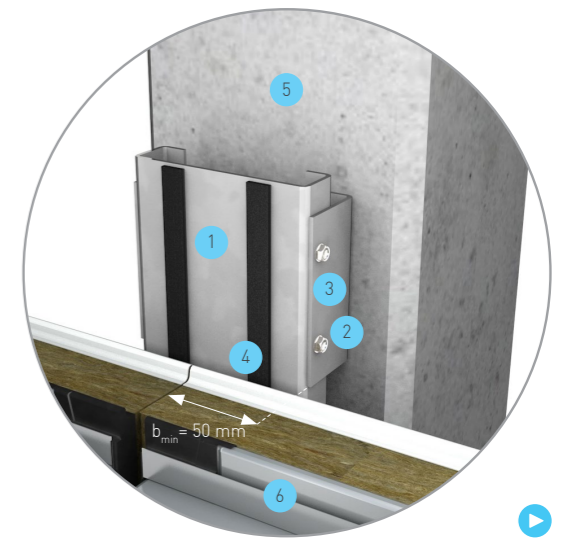

**A**  
The classic steel structure is suitable for Qbiss One façade elements installation, when required tolerances are met. The substructure must be installed with a tolerance of  $\pm 2$  mm. Otherwise additional support structure needs to be introduced.

**B**  
Check horizontal support structure level. It is crucial to ensure the right level of the opening substructure into which a window, door or other element is installed and directly connected to the adjacent Qbiss One façade elements. Alignment of the openings substructure with the basic structure must be provided. If not provided, insufficient sealing between the opening element (window, door, frame etc.) and Qbiss One façade element will occur. Consequently, the transversal and longitudinal joints will not be finished properly, causing the façade to lose its water tightness, airtightness and additional aesthetic deviations might appear or additional problems might appear.

**C**  
Steel column face: The minimum required contact surface of the Qbiss One modular façade system is given by structural analysis for each separate project. When no structural calculation is required, the minimal width of the contact surface ( $b_{min}$ ) is 50 mm per edge of façade element. A levelling structure must be used when the structure is not within permissible tolerances.

[👉 Link to installation preferences chapter](#)

**!**  
In order to reach project required façade airtightness an additional sealing of structure members must be performed. For a sufficient sealing a PE-butyl tape is applied on top of all gaps that appear amongst structural elements or extrusions.

INSTALLATION NOTES - STEP 2

**NOTES / Each Qbiss One façade element is clearly marked with individual element installation reference. It is contractor's responsibility to follow the sequence of installation of the façade elements against elevation drawings.**

Elements are fixed to a steel structure by use of integrated fixing profiles with screws. Such solution enables a quick installation without visible screws on the external side of the façade. In order to handle and lift the elements, vacuum grippers or special mechanical grippers attached to the longitudinal joint of the Qbiss One façade elements are recommended. The installation team is responsible to check and must use the correct type of vacuum grippers (octopus), suitable for use (lifting) of self-supporting sandwich panels.

Vertical load fixation of Qbiss One elements must be performed with screws through internal steel sheet into support structure in both upper corners. Fixing through façade element internal metal sheet is carried out using special screws for securing thin metal sheets. During installation the alignment of Qbiss One element must be performed and monitored.



BASE 3D DETAIL

- 1 EPDM drip element
- 2 Qbiss One façade element
- 3 Drip flashing
- 4 Cladding element carrier - U profile
- 5 Sealing tape

[CAD download centre](#)

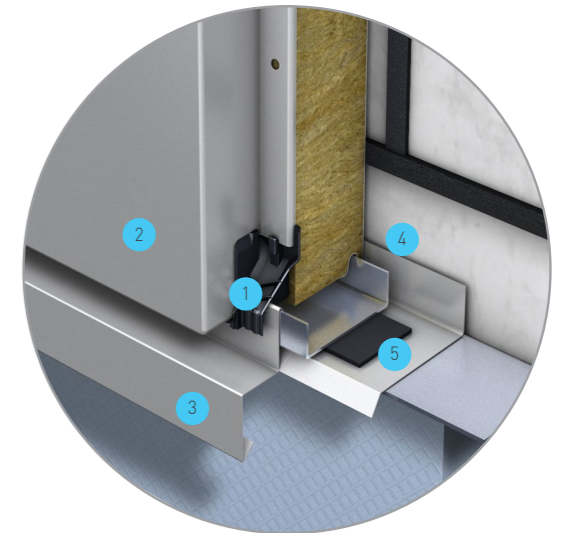

**A**  
In order to ensure airtightness and to prevent condensation within the Qbiss One façade element, a sealing tape is installed onto the contact surface of the support structure / substructure. The sealing tape must be applied in a way that it has closed loop, without free places between connections or vertical and horizontal sealing tape, to provide vapour barrier.

**B**  
Element carriers (U shaped) are located maximum 150mm from element ends or 1 pcs per meter. Ensure that carriers are accurately lined and levelled. Permissible deviation along the whole length of individual façade element is  $\pm 0.5$  mm. The absolute deviation of alignment for the whole distance of the building façade is  $\pm 2$  mm.

**C**  
Drip flashing installation sequence:

1. Level and attach cladding element holder with anchor bolt to base concrete.
2. Insert secondary drip flashing and apply sealing tape at the point of element carriers.
3. Fit element carriers, located max 150mm from element ends with bulb tight rivets (min. 2 rivets / element carriers). Ensure that carriers are accurately lined and levelled.
4. Bottom end sealing at the end of element transversal joint are performed by inserting the draining EPDM drip element onto the main beam connection.
5. Fix and level drip flashing using low profile fasteners.
6. Drip flashing joint incorporates butt straps sealed with two runs of non-setting gungrade butyl sealant.
7. Attach Qbiss One element to the finished base detail.

[Link to system sealing chapter](#)

**!**

- In order to reach project required façade airtightness an additional sealing at the place of the facade element inner steel sheet and structure face must be applied. For a sufficient sealing a two runs of EPDM mastic seal is applied.
- When installation day is completed, facade elements must be protected from water and other liquids seeping into the core insulation.

INSTALLATION NOTES - STEP 3

**NOTES / Qbiss One façade elements are fixed to main structure or substructure with two types of screws through the internal and external steel sheet. Qbiss One façade element has pre-fabricated bores at the points of fixation (D1.1).**

Some installations may require additional fasteners depending on spans and wind loadings. Number of screws is prescribed in the project based on the structural analysis. If number of screws is not defined, it equals the number of holes in the fixing plate profile. Usually, this means at least 3 screws / joint.

Correct positioning of adjacent façade elements means:

- longitudinal joint dimension is 23 mm -1 / +0.5,
- transversal joint dimension is 25 mm -1 / +2,
- horizontal alignment ± 0.5 mm.



JOINT 3D DETAIL

- 1 Sealing tape
- 2 Qbiss One façade element
- 3 Load bearing fixing plate
- 4 EPDM corner gasket
- 5 Drip flashing at connection of 4 Qbiss One elements

[CAD download centre](#)

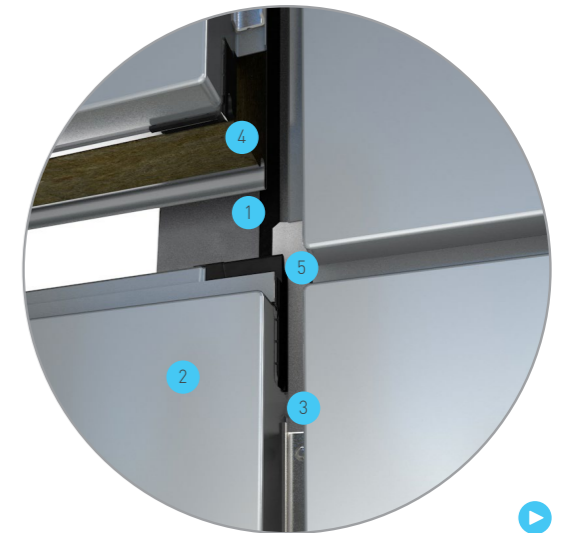

**A**  
Sharp corner ending of the Qbiss One modular façade is performed before adjacent basic elements are positioned. Final attachment is performed by use of attachment profiles after adjacent elements are set in place.

**B**  
Support for the element ending must be laid horizontally, otherwise, the uniformity of the horizontal and vertical joints of Qbiss One façade system cannot be guaranteed.

Install the Qbiss One façade element from the top to down to final position. Levelling device must be used to ensure that the façade elements are laid horizontally. Tongue of the longitudinal joint must be pointed upwards. Attach the Qbiss One façade element on both sides with vertical load fixing screw through the internal metal sheet into the vertical sub-structure.

**C**  
Insert drainage drip flashing at connection of 4 Qbiss One façade elements. Drainage drip flashing prevents rain water to enter the system and secures any eventual water drainage from the transversal joint.

**D**  
During installation, insert the centring cross into the joint to facilitate element positioning. After installing adjacent elements, the centring cross must be removed. Longitudinal joint must be pointed upwards and tight contact without air gaps between neighbouring Qbiss One modular façade elements on longitudinal joints must be assured.

**E**  
Pre-drilling is required when using of self-tapping screws. Swarfs (with self-drilling and self-tapping screws) have to be completely removed from Qbiss One façade elements immediately.

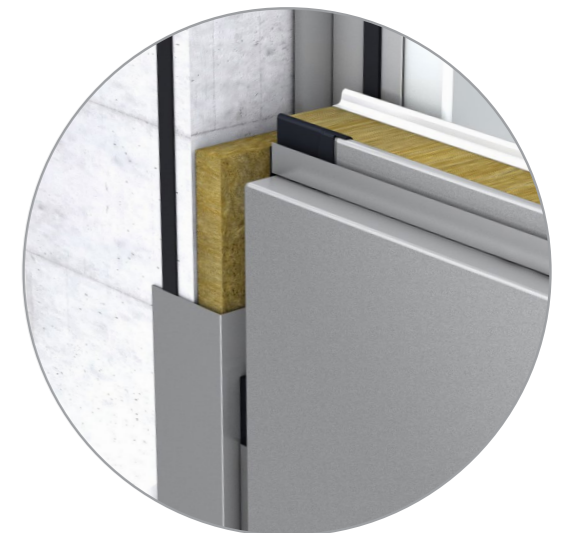

**!** Do not over-tighten screws as deformations visible on the whole external steel sheet of Qbiss One elements may occur (highlighting core mineral wool lamellas). Only undamaged screws without washers and without thread under the screw head may be used.



INSTALLATION NOTES - STEP 4

**NOTES / Transversal joint must be sealed in order to prevent rainwater or increased air humidity from entering the joint and the mineral wool of Qbiss One façade elements.**

The standard length for decorative Alu. extrusion HF40 is 4 meters. Extension is performed by using a dilation slot of 10 mm. Profiles can be cut to size upon customers request according to specifics of individual projects and installation details.

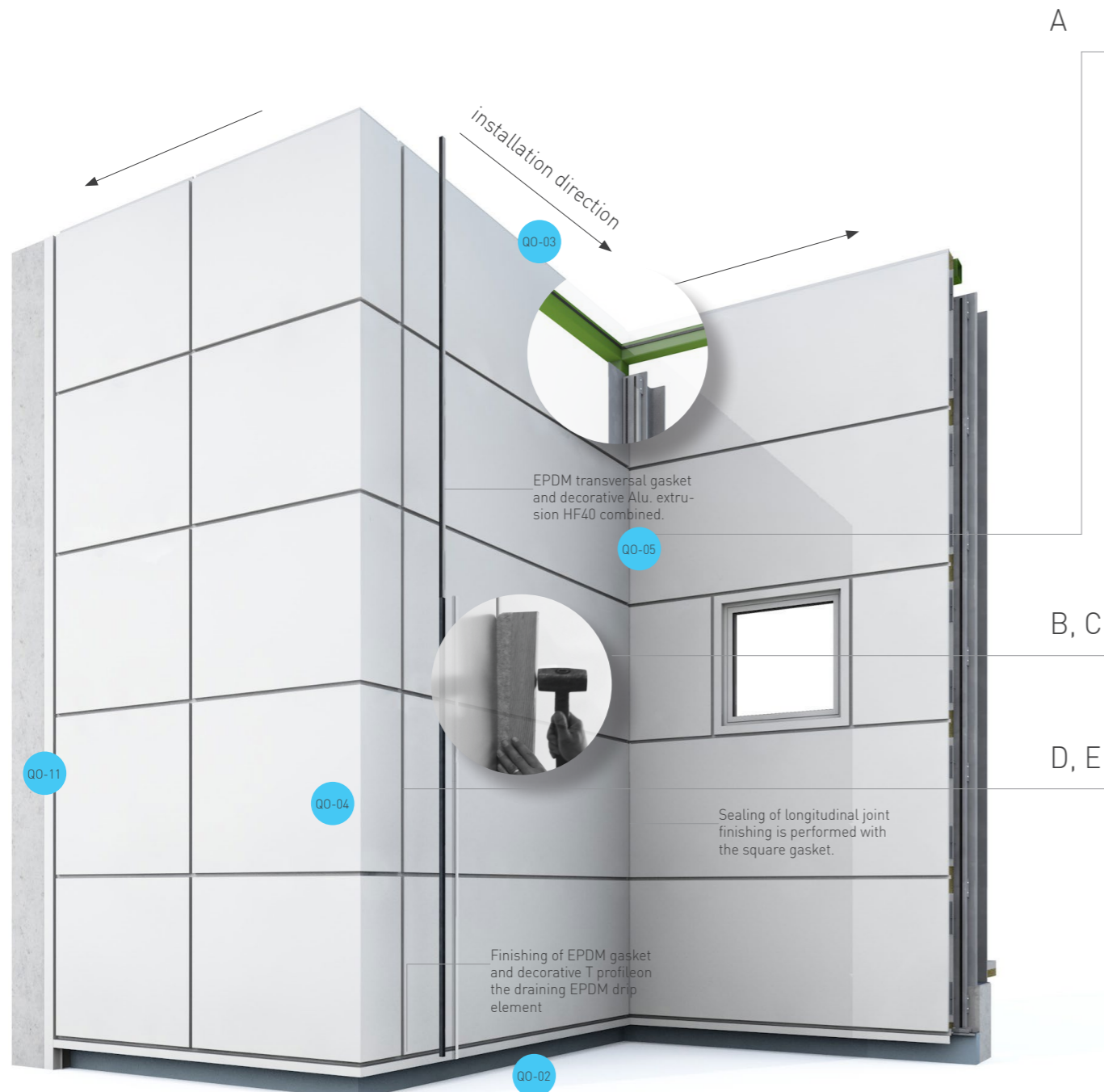

JOINT 3D DETAIL

- 1 Sealing tape
- 2 Qbiss One façade element
- 3 Load bearing fixing plate
- 4 EPDM corner gasket
- 5 Drip flashing at connection of 4 Qbiss One elements

[CAD download centre](#)

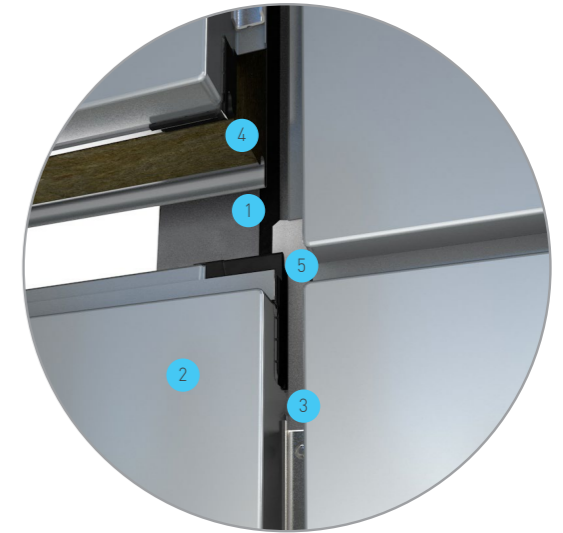

**A**  
Transversal joint must be filled with mineral wool. Structural calculation for fixing screws quantity needs to be performed. Square gasket is required to prevent water ingress to the inside of the façade system. Additional internal corner installation sequences are explained in internal corner detail.

**B**  
After drip flashing is inserted, an additional sealing must be performed. Lubricant must be applied to reduce friction and facilitate the inserting the EPDM gasket together with decorative Alu. extrusion HF40 on the transversal joint.

Transversal joint gasket and the decorative extrusion HF40 must be installed before they are inserted into the transversal joint. The standard length for decorative extrusion HF40 profiles is 4 meters. Extension is performed using a dilation slot of 10 mm, meaning that the profiles are not in contact.

[Link to system sealing chapter](#)

**C**  
Use bar and a hammer to insert joined transversal EPDM gasket and decorative Alu. extrusion HF40.

**D**  
The deviations can be compensated using the Qbiss One façade elements with the transversal joint tolerance by compressing or expanding the area by +2 -1 mm.

**E**  
Qbiss One façade elements have a protective foil on outer and optionally on inner surface to protect the coloured surfaces against eventual minor scratches during transport, handling and installation. Every day after ending the installation, the foil must be removed from each façade element / façade completely.

- ! Extending the gasket and the decorative Alu. extrusion HF40 must not be performed on the same spot!
- Minimum distance between gasket and decorative Alu. extrusion HF40 extensions is 500 mm.
- Extension is performed using the dilation slot of 10 mm.

### INSTALLATION NOTES - STEP 5

**NOTES /** Sealing of the parapet wall is performed by finishing all the elements in the transversal joint, where the drip flashing of a joint of 4 elements is trimmed to the level of the longitudinal joint. The parapet wall finish is performed by using a parapet wall cap.

Window frame in the joint, flush with the surface of Qbiss One façade elements detail can only be executed when the building is dry and by providing a vapour barrier on the warm side.

When attaching aluminium window profiles, sealing with the façade element must be provided. The window frame and the lining must be installed together with the façade elements in order to ensure sealing and insulation. Window sills that are longer than 4.0 m must be diluted.

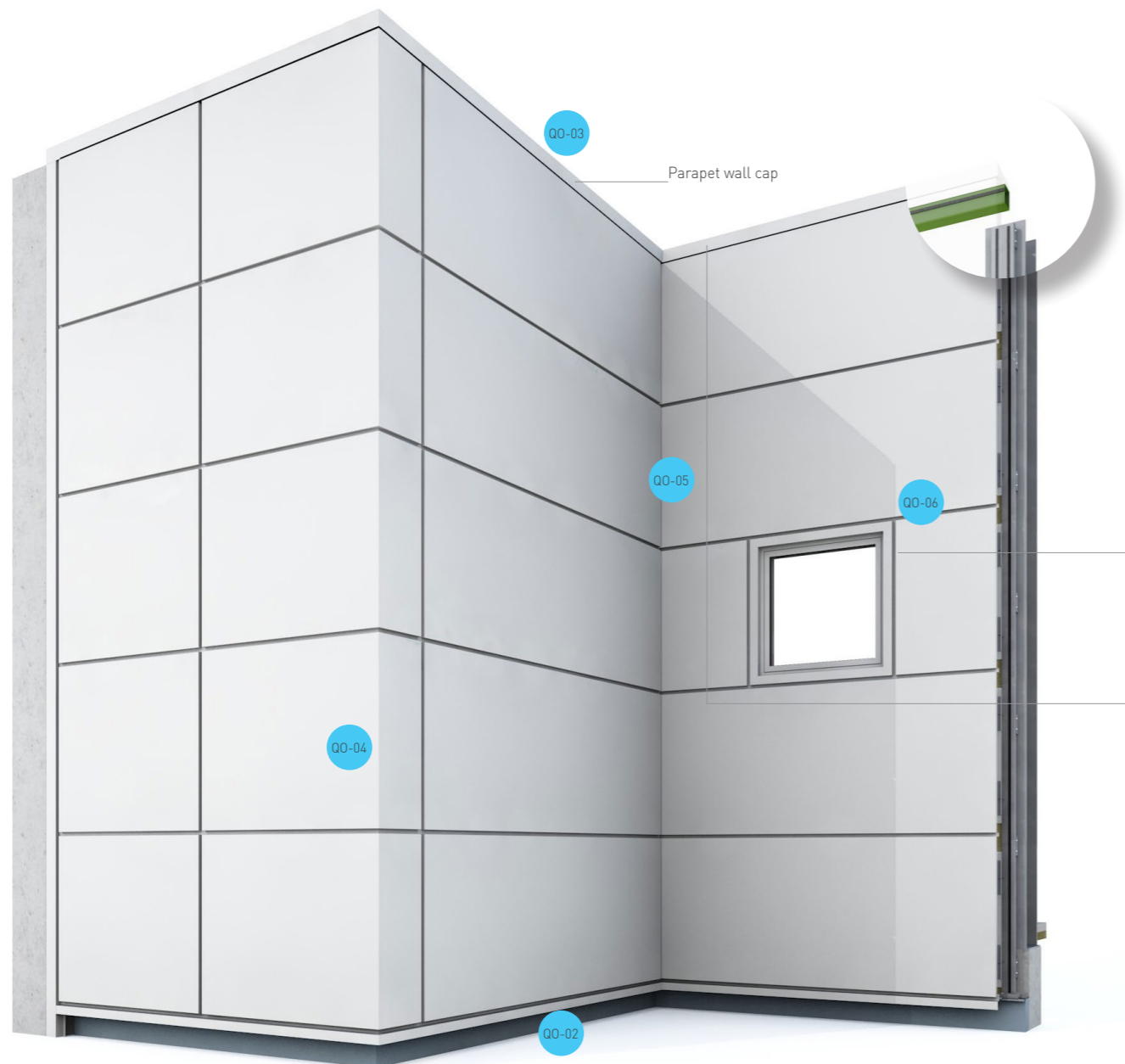

### PARAPET WALL 3D DETAIL

- 1 Parapet cap support profile
- 2 Qbiss One façade element
- 3 EPDM corner gasket
- 4 Parapet cap
- 5 Sealing tape

[CAD download centre](#)

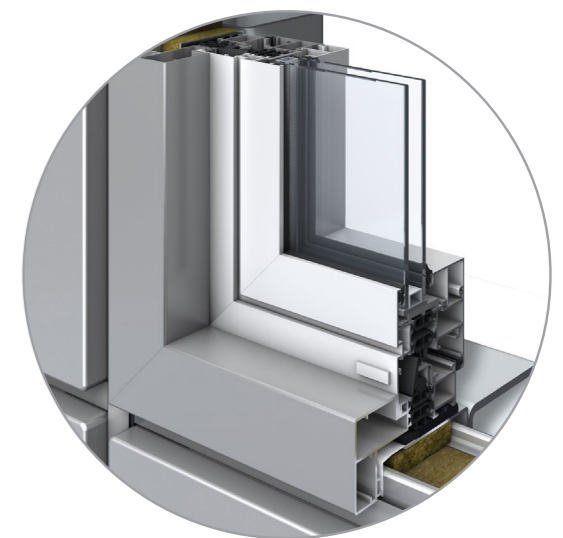
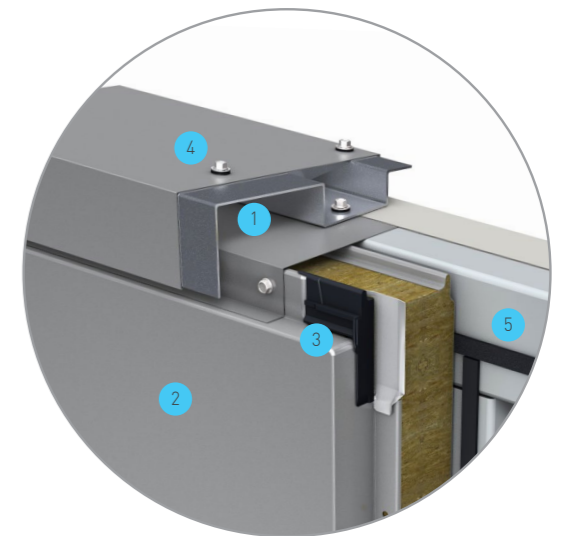

**A** Window, door frames and other opening are installed simultaneously with the Qbiss One façade elements.

Installation sequence:

1. Attach the upper and lower Qbiss One façade element into the longitudinal joint.
2. Fill the empty space with thermal insulation between the load-bearing profile and the Qbiss One façade elements.
3. Glue the waterproof membrane onto load-bearing profile and Qbiss One façade element.
4. Apply the pre-compressed sealing tape on window frame according to the requirements of the sealing tape supplier.
5. Insert the window frame.
6. Fill the gap with thermal insulation if needed and attach the window frame (2 screws per meter).
7. Install the waterproof membrane to the window frame from the upper side.
8. On the inner side, apply the vapour impermeable silicon or round PE gasket into the joint between the window profile and the window load-bearing profile.
9. Seal the transversal joint.

[Link to system sealing chapter](#)

**B** Parapet wall installation sequence:

1. Install the lining support to the parapet wall substructure using screws.
2. Glue the waterproof membrane onto the façade element and the substructure.
3. Attach the support for the parapet wall cap through the support for the lining onto the parapet wall substructure with blind rivets.
4. Place the parapet wall cap onto the top / final Qbiss One horizontal façade element.
5. Attach the parapet wall cap with a screw to the lining support. 1 screw per meter is added in longitudinal joint to avoid deflection.

**!**

- With installation of window frames is necessary to consider the detail of the project. Therefore, the installation sequences described can only be taken as a guide for the installation.
- At the parapet wall façade elements must be screwed into the structure along the whole area in order to prevent outward migration.

### INSTALLATION NOTES - BRICK INSTALLATION

**NOTES /** The installation is continued in the prescribed direction (left or right) using installation crosses and by regularly checking the horizontal / vertical alignment of installed Qbiss One façade elements.

The installation in the next row continues with a shift as defined by project documentation. The transversal joint of two elements starts or finishes along the top or bottom Qbiss One façade element. Correct positioning of adjacent façade elements means that longitudinal joint measures 23 mm, and transversal joint measures 25 mm.

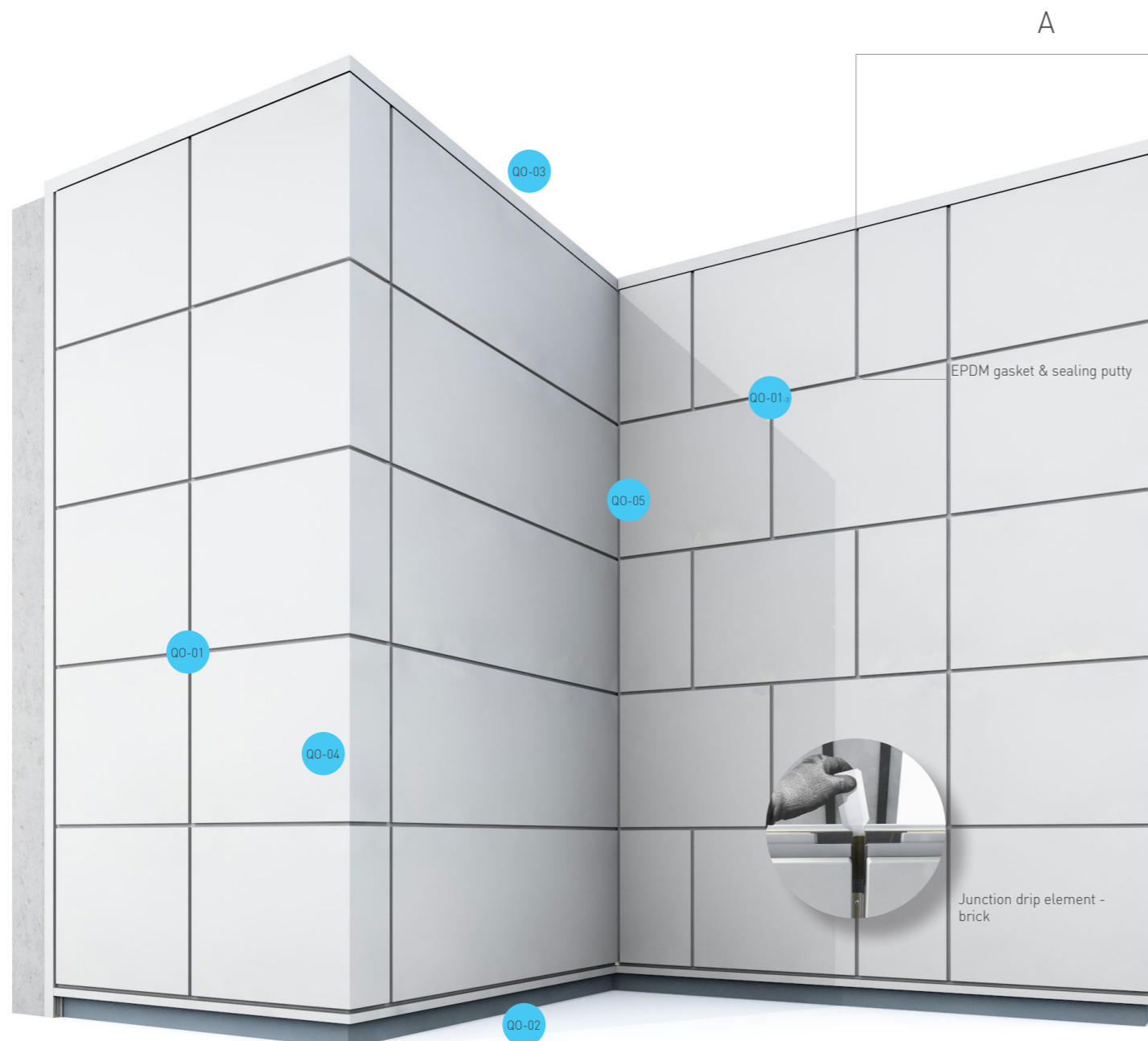

### BRICK SYSTEM 3D DETAIL

- 1 EPDM drip element (with sealing compound)
- 2 Qbiss One façade element
- 3 EPDM corner gasket
- 4 Sealing tape
- 5 Decorative Alu. extrusion

[CAD download centre](#)

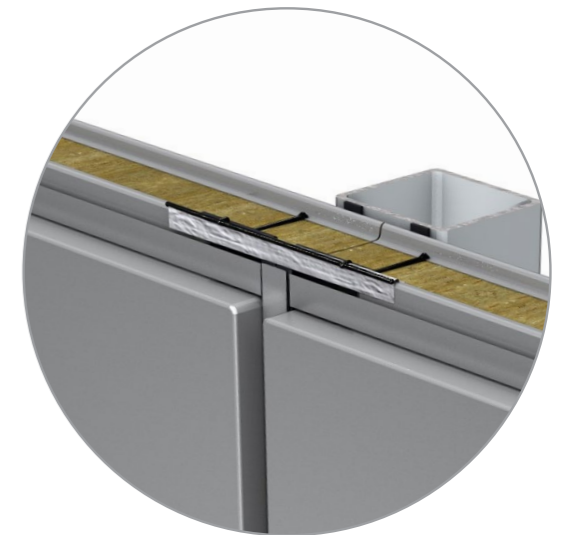
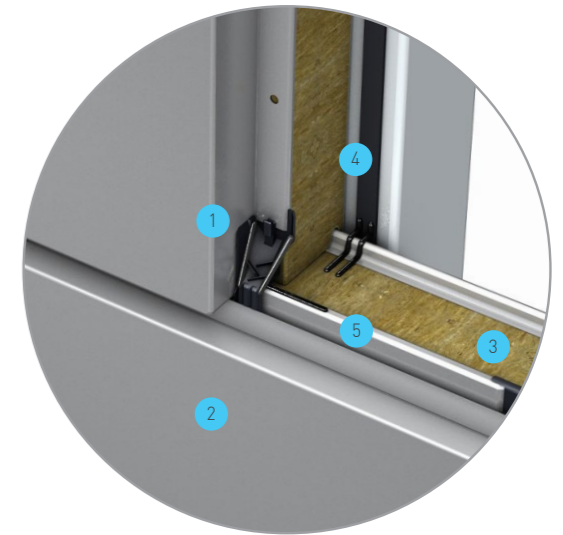

A

Brick joint installation sequence:

1. Apply the sealing element onto the longitudinal joint of Qbiss One façade element.
2. Place the top Qbiss One façade element onto the bottom Qbiss One façade element with a help of a seaming tool.
3. Apply the sealing compound and insert the draining EPDM drip element.
4. Press Qbiss One façade element to the already attached element.
5. Insert the installation cross to enable correct positioning.
6. Perform a vertical load fixation with the screw on the both sides of Qbiss One element.
7. Attach Qbiss One façade element with screws through attachment profiles.
8. Install the half drip flashing for a joint of 4 façade elements.
9. Apply lubricant into the transversal joint.
10. Assemble the transversal joint gasket and the decorative Alu. extrusion HF40.
11. Insert both elements into the transversal joint, beginning with the top façade element.
12. Gradually press both elements into the transversal joint with the bar and a hammer.
13. Apply PE-butyl tape and gluing putty to connection of transversal and longitudinal joint.

[Link to system sealing chapter](#)

**!**

- Sealing or closing of the transversal joint must be performed as you go, before installing the top Qbiss One façade element! Otherwise, adequate sealing and draining of the Qbiss One modular façade system cannot be guaranteed.
- With brick installation standard centering cross can not be used. »T« shaped centering tool is used to facilitate element positioning.

# VERTICAL INSTALLATION DETAILS

## INSTALLATION NOTES - STEP 1

**NOTES / Wear protective gloves and clothing when handling sharp elements, edges and corners. Before installation work, check whether the installation site is subject to any particular requirements regarding occupational safety. Always follow the local occupational safety provisions.**

Before installation the actual state of the building and the placement of the substructure against the raster in the design project must be checked. A geodetic scan of the building (concrete or brick wall) or structure (steel, concrete, wood) is required to determine suitability of the structure. If it does not fit within permissible tolerances, adjustable levelling substructure must be used. Before installing Qbiss One façade elements, deviations must be measured. The deviations can be compensated by using Qbiss One façade elements with the transversal joint tolerance by compressing or expanding the area by +2 / -1 mm.

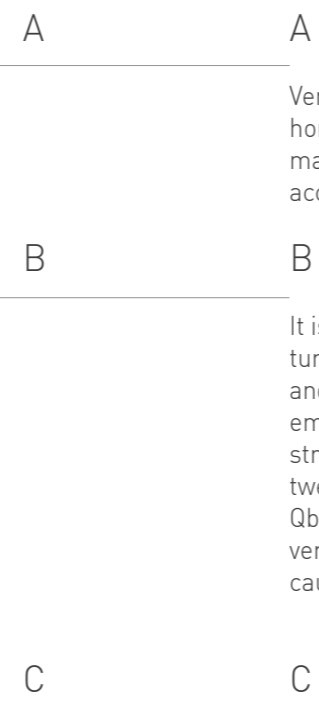
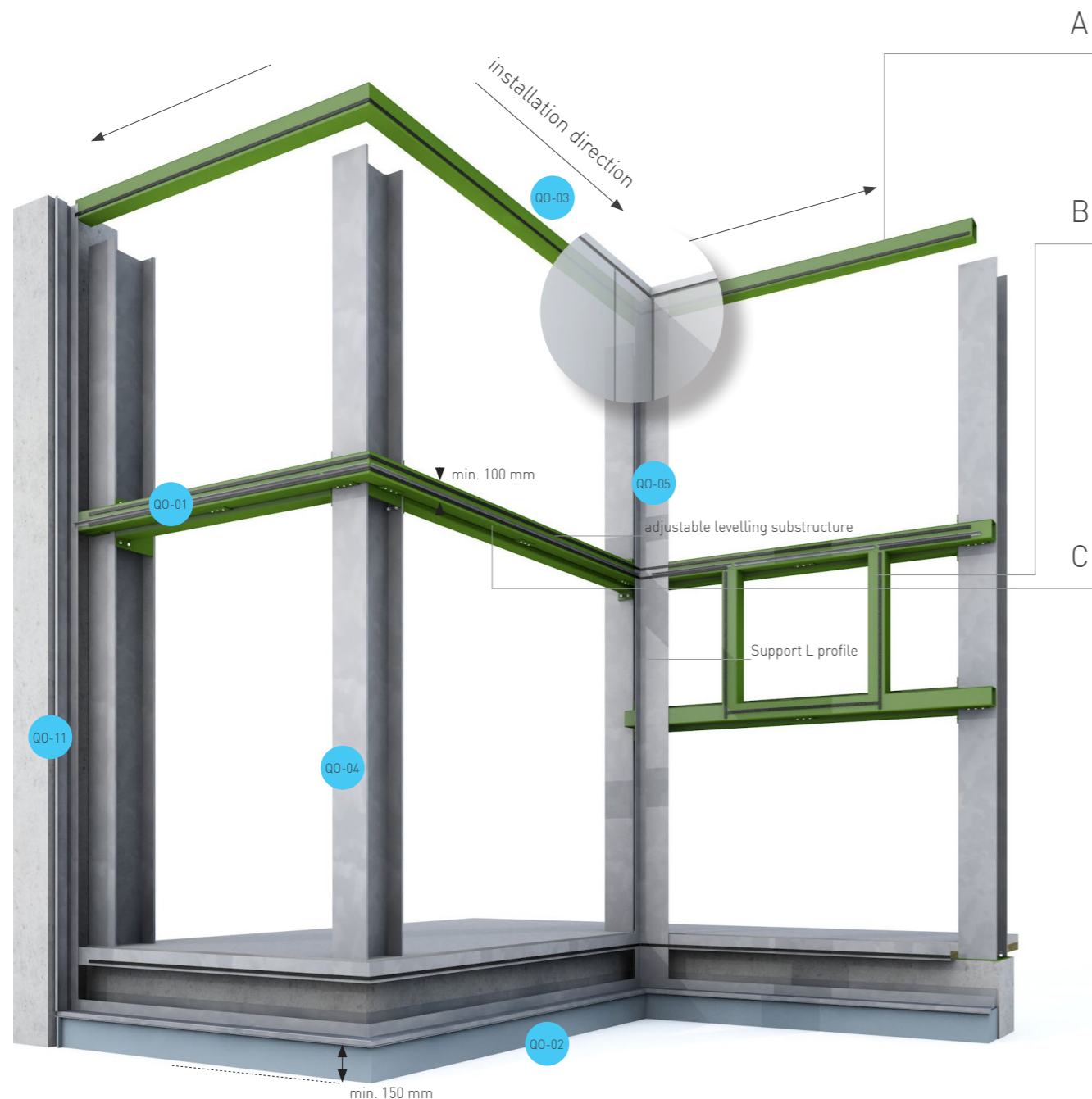

## ADJUSTABLE LEVELLING SUBSTRUCTURE 3D DETAIL

- 1 Support frames
- 2 Contact surface levelling profile (fixed with self-tapping screws)
- 3 Steel structure
- 4 Joint profile

[🌐 CAD download centre](#)



**A**  
Vertical attachment Qbiss One elements must be made on a horizontal classic steel substructure which is attached to the main structure. The horizontal substructure must be within acceptable tolerances.

**B**  
It is crucial to ensure the right level of the opening substructure into which a window, door or other element is installed and directly connected to the adjacent Qbiss One façade elements. Alignment of the openings substructure with the structure must be provided. If not, insufficient sealing between the opening element (window, door, frame etc.) and Qbiss One façade element will occur. Consequently, transversal and longitudinal joints will not be finished properly, causing the façade to lose its water / air tightness.

**C**  
Steel substructure face: The minimum required contact surface of Qbiss One modular façade system is provided by structural analysis for each separate project. In cases when there is no calculation, the minimal width of the contact surface is (b min) is 50 mm per edge of façade element. A levelling structure must be used when the structure is not within permissible tolerances.

[🔗 Link to installation preferences chapter](#)

**!**  
In order to reach project required facade airtightness an additional sealing of structure members must be performed. For a sufficient sealing a PE-butyl tape is applied on top of all gaps that appear amongst structural elements or extrusions.

INSTALLATION NOTES - STEP 2

**NOTES / Each Qbiss One façade element is clearly marked with individual element installation reference. It is contractor's responsibility to follow the sequence of installation of the façade element against elevation drawings.**

Façade elements are fixed to a steel structure by integrated fixing plate profiles and inner steel sheet with screws. Such solution enables a quick installation without visible screws on the external side of the façade. In order to handle and lift the elements, vacuum grippers are recommended. Installation team is responsible to check and must use correct type of vacuum grippers (octopus), suitable for use (lifting) of self-supporting sandwich panels.

Vertical load fixation of Qbiss One elements must be performed with screws through internal steel sheet into support structure in both upper corners. Fixing through façade element internal metal sheet is carried out using special screws for securing thin metal sheets. During installation the alignment of Qbiss One element must be performed and monitored.



BASE 3D DETAIL

- 1 Cladding element carrier L profile
- 2 Qbiss One façade element
- 3 Thermal insulation - mineral wool
- 4 Drip flashing
- 5 Sealing tape

[CAD download centre](#)

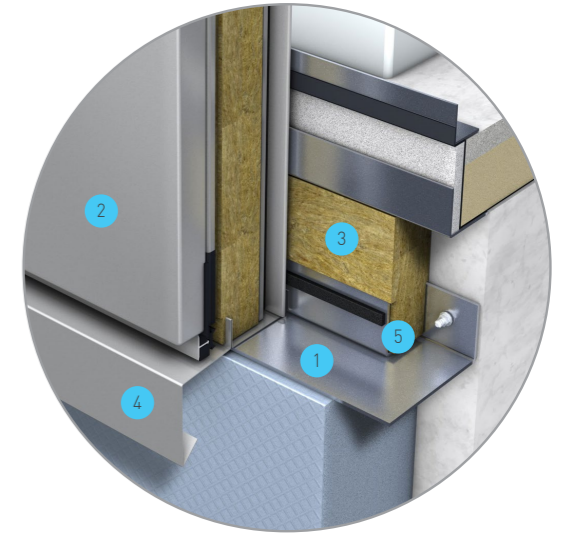

**A**  
In order to ensure airtightness and to prevent condensation within the Qbiss One façade element, a sealing tape is installed onto the contact surface of the support structure / substructure. Sealing tape must be applied in a way that it has closed loop, without free places between connections or vertical and horizontal sealing tape, to provide vapour barrier.

**B**  
Permissible deviation along the whole length of individual façade elements is  $\pm 0.5$  mm. The absolute deviation of alignment for the whole distance of the building façade is  $\pm 2$  mm.

At the point where Qbiss One façade element is placed onto the drip flashing of the façade element, the mineral wool must be cut to ensure proper seating. Sealing of the joint is performed by inserting EPDM transversal gasket and the decorative extrusion HF40 into transversal joint between drip flashing and façade element.

**C**  
Drip flashing installation sequence:  
 1. Perform riveting of drip flashing of Qbiss One façade element to the ending L profile. Support for the Qbiss One façade element ending must be aligned with substructure.  
 2. Notch the element at the bottom at the site of placing it on the drip flashing.  
 3. Place the Qbiss One façade element onto the drip flashing.  
 4. Place the joint gasket with decorative Alu. extrusion HF40 onto position of horizontal joint.  
 5. Attach Qbiss One façade element on both sides with a screw through the internal metal sheet and the joint profile (2 screws / element).

**!**

- It is crucial to ensure the contact surface of the first row of the Qbiss One elements is level. Otherwise irregular vertical placing of elements will occur, causing insufficient transversal joint water tightness.
- For a sufficient sealing a two runs of EPDM mastic seal is applied.
- When installation day is completed, facade elements must be protected from water and other liquids seeping into the core insulation.

### INSTALLATION NOTES - STEP 3

**NOTES /** Qbiss One façade elements are fixed to façade structure or substructure with two types of screws through the internal and external metal sheet. Qbiss One façade element has pre-fabricated bores at the points of fixation. Using the same number of screws as number of bores is a must.

Number of screws is prescribed in the project based on the structural analysis. If the number of screws is not defined, it equals the number of holes in the attachment profile. Usually, this means 3 screws / joint.

Correct positioning of adjacent façade elements means:

- longitudinal joint dimension is 23 mm -1 / +0.5,
- transversal joint dimension is 25 mm -1 / +2,
- horizontal alignment ± 0.5 mm.



### JOINT 3D DETAIL

- 1 Sealing tape
- 2 Qbiss One façade element
- 3 Load bearing fixing plate
- 4 EPDM corner gasket
- 5 PE-butyl tape

🌐 [CAD download centre](#)

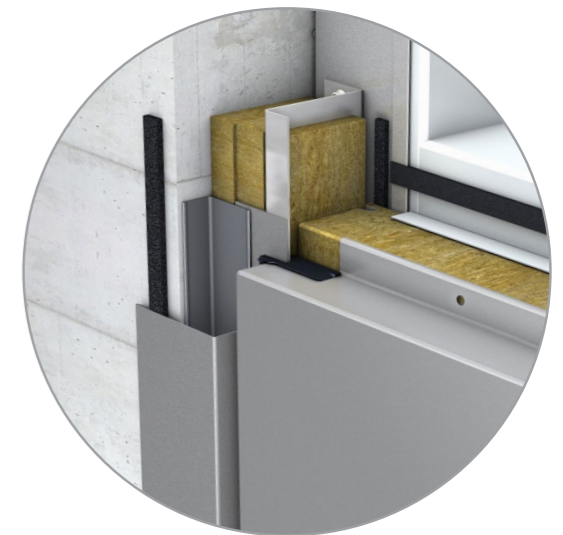
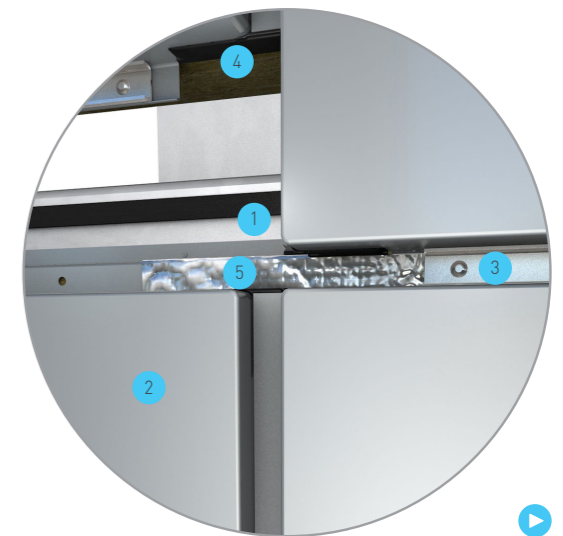

#### A

Installation follows the direction of laying the façade elements. Bottom and side of Qbiss One façade elements are placed and attached with lining in the transversal joint and with a help of a seaming tool. Sharp corner ending of the Qbiss One modular façade is performed after the first adjacent façade element is positioned. Final attachment is performed by attachment profiles after adjacent elements in both rows are in place.

#### B

Support joint profile for the element ending must be laid horizontally, otherwise, the uniformity of the horizontal and vertical joints of the Qbiss One façade system cannot be guaranteed. Install Qbiss One façade element from top to the bottom to final position with a help of a seaming tool. Levelling device must be used to ensure that the elements are laid horizontally. The right joint type of the Qbiss One element must be pointed upwards. Attach the façade element on both sides with vertical load fixing screw through the internal metal sheet into the horizontal substructure.

#### C

Apply PE-butyl tape to the joint of four vertically installed Qbiss One façade elements, after elements are rightly placed and fixed.

#### D

During installation, insert the centring cross into the joint to facilitate element positioning. After installing adjacent elements, centring cross must be removed. Transversal joint must be pointed upwards and in tight contact without air gaps between neighbouring Qbiss One modular façade elements on longitudinal joints must be assured.

#### E

Pre-drilling is required when selftapping screws are used. Swarfs (with selfdrilling and selftapping screws) have to be completely removed from Qbiss One façade elements immediately.

! Do not over-tighten the screws as deformations visible on the whole external metal sheet of Qbiss One elements may occur (highlighting core mineral wool lamellas). Only undamaged screws without washers and without thread under the screw head may be used.

• Be aware not to cover drainage channel opening of EPDM corner gasket with the PE-butyl tape. The channel enables water to drain out of the system.

INSTALLATION NOTES - STEP 4

**NOTES /** Transversal joint must be sealed in order to prevent rain water or increased air humidity to enter the joint and the interior of Qbiss One façade elements.

The standard length for decorative Alu. extrusion HF40 is 4 metres. Extension is performed using a dilatation slot of 10 mm. Profiles are cut to size upon customers request according to specifics of individual projects and installation details.

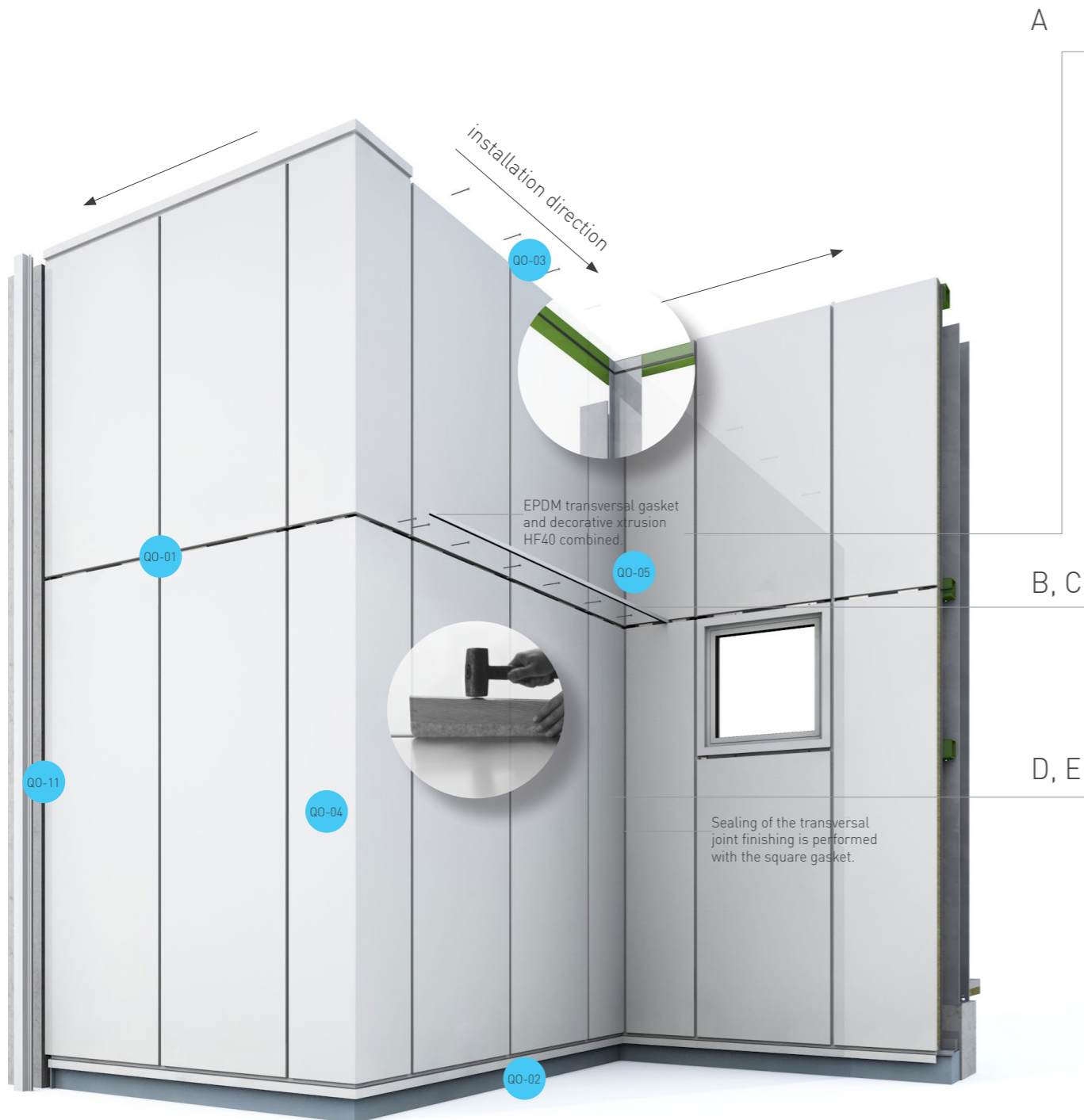

INTERNAL CORNER 3D DETAIL

- 1 EPDM membrane
- 2 Corner flashing
- 3 Qbiss One façade element
- 4 Thermal insulation - mineral wool
- 5 Load bearing Z profile

[CAD download centre](#)

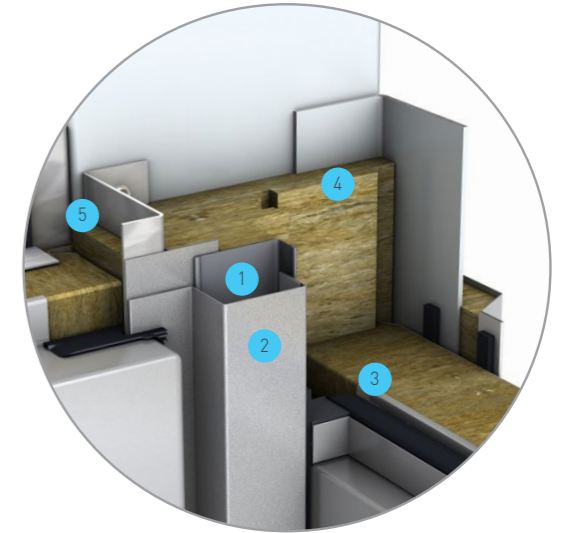

**A**  
Longitudinal joint must be filled with mineral wool. Static calculation for fixing screws quantity needs to be performed. The square gasket with mastic seal needs to be applied in the transversal joint to prevent water ingress to the inside of the façade system. Additional internal corner installation sequences are explained in internal corner detail.

**B**  
After insertion of the PE-butyl tape, additional tightening must be performed. Lubricant is applied to reduce friction and facilitate the inserting the EPDM gasket together with decorative Alu. extrusion HF40 on the transversal joint.

Transversal joint gasket and the decorative Alu. extrusion must be installed before they are inserted into the transversal joint. The standard length for decorative extrusion profiles is 4 metres. Extension is performed using a dilatation slot of 10 mm, meaning that the profiles are not in direct contact.

[Link to system sealing chapter](#)

**C**  
Use bar and a hammer to insert joined transversal EPDM gasket and decorative Alu. extrusion HF40.

**D**  
Deviations can be compensated using the Qbiss One façade elements with the transversal joint tolerance by compressing or expanding the area by +2 / -1 mm.

**E**  
Qbiss One vertical façade elements have a protective foil on outer and optionally on inner surface to protect the coloured surfaces against eventual minor scratches during transport, handling and installation. Every day after ending the installation, the foil must be removed from each façade element / façade completely.

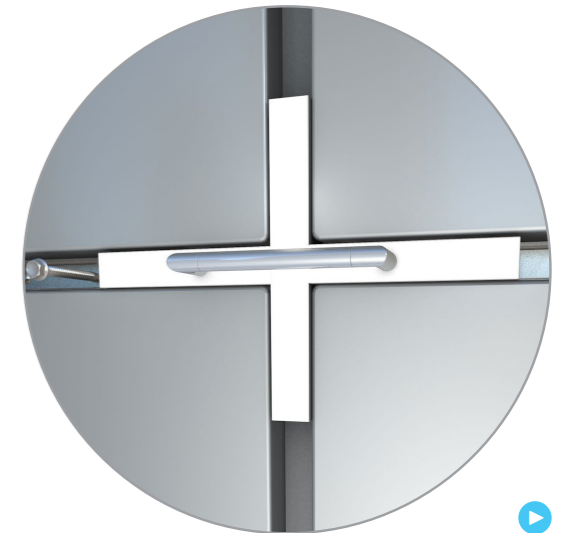

- ! Extending the gasket and the decorative Alu. extrusion HF40 must not be performed on the same spot!
- Minimum distance between both extensions is 500 mm (or up or down).
- Extension of decorative Alu. extrusion HF40 is performed using the dilatation slot of 10 mm.

### INSTALLATION NOTES - STEP 5

**NOTES /** Sealing of parapet wall is performed by finishing all the elements in the transversal joint. Waterproof membrane glued onto Qbiss One façade element also seals transversal joint gap of two Qbiss One elements. The parapet wall finish is performed by using a parapet wall cap.

Window frame in the joint, flush with the surface of Qbiss One façade elements detail can only be executed when the building is dry and when a vapour barrier is installed on the warm side.

When attaching aluminium window profiles, sealing with the façade element must be provided. Window frame and the lining must be installed together with façade elements in order to ensure sealing and insulation. Window sills that are longer than 4.0 m must be diluted.



### WINDOW 3D DETAIL

- 1 Window frame profile
- 2 Decorative Alu. extrusion HF40
- 3 Outer glass fixing element
- 4 Qbiss One façade element
- 5 PE-butyl tape
- 6 Thermal insulation - mineral wool

 [CAD download centre](#)

A

Window, door frames and other opening are installed simultaneously with the Qbiss One façade elements. The window frame is designed for the installation into all four joints of the Qbiss One façade system. It is flushed with the outer surface of Qbiss One façade elements.

Installation sequence:

1. Place and attach the bottom and side of Qbiss One façade elements with lining in the transversal joint and with a help of a seaming tool.
2. Fill the empty space with thermal insulation between load bearing profile and the Qbiss One façade elements.
3. Glue waterproof membrane onto the bottom load-bearing profile and the transversal and to the longitudinal joint of the Qbiss One façade element.
4. Apply sealing tape to waterproof membrane and to load bearing profile of window opening according to the sealing tape supplier requirements.
5. Apply insulation foam (complete circumference).
6. Insert the window frame.
7. Attach the window frame (2 screws per meter) around the window frame.
8. On the inner side apply the vapour impermeable silicon and then a round PE gasket into the joint between the window profile and the window load-bearing profile.
9. Seal the transversal joint.

 [Link to system sealing chapter](#)

B

Parapet wall installation sequence:

1. Attach façade element with screws through the internal sheet metal.
2. Glue waterproof membrane onto the outer steel of façade element and the substructure.
3. Attach Qbiss One vertical façade element to the substructure by fixing through element outer steel sheet.
4. Attach parapet wall cap support with screws into the substructure.
5. Place parapet wall cap onto the parapet wall cap support and attach it with a screw.

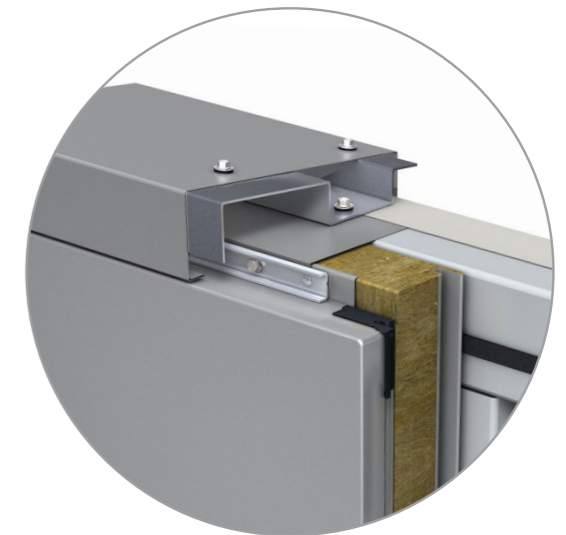
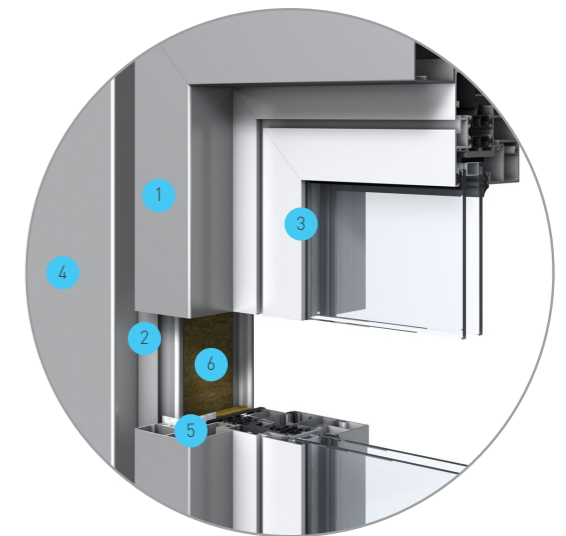

!

- With installation of window frames is necessary to consider the detail of the project. Therefore, the installation sequences described can only be taken as a guide for the installation.
- It is crucial to ensure the right level of the opening substructure into which a window, door or other element is installed that is directly connected to the adjacent Qbiss One façade elements.



## INSTALLATION NOTES - BRICK INSTALLATION

**NOTES /** Installation is continued in the prescribed direction (left or right) using installation crosses and by regularly checking the horizontal / vertical alignment of installed Qbiss One façade elements.

Installation in the next row continues with a shift as defined by project documentation. Longitudinal joint of two elements starts or finishes along the top or bottom Qbiss One façade element.

Correct positioning of adjacent façade elements means:

- longitudinal joint dimension is 23 mm -1 / +0.5,
- transversal joint dimension is 25 mm -1 / +2,
- horizontal alignment  $\pm 0.5$  mm.



## BRICK SYSTEM 3D DETAIL

- 1 PE-butyl tape
- 2 Qbiss One façade element
- 3 Joint L profile
- 4 Sealing tape
- 5 Steel substructure

[CAD download centre](#)

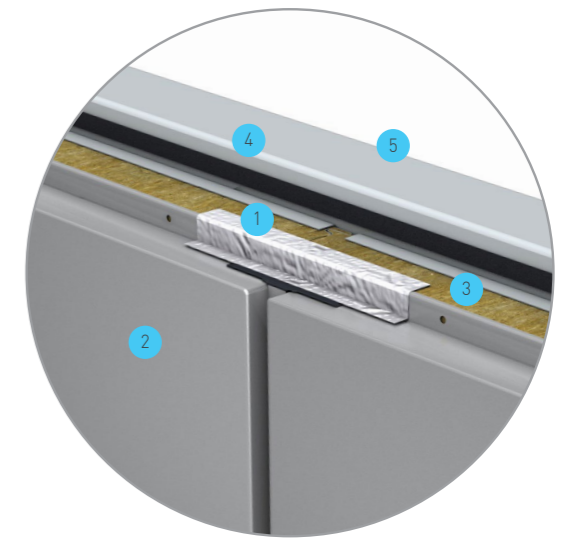

### A

Brick joint installation sequence:

1. Apply PE-butyl tape to transversal joint gap of two bottom Qbiss One façade element.
2. Place the top Qbiss One façade element onto the bottom Qbiss One façade element with a help of a seaming tool.
3. Press Qbiss One façade element to pre-installed façade element.
4. Insert installation T-centring tool to enable correct positioning of façade element.
5. Perform a vertical load fixation with the screw on both sides of Qbiss One element.
6. Install Qbiss One façade element with screws through the fixing plates element bores.
7. Remove the T shaped centring tool to enable correct positioning.
8. Apply lubricant to transversal joint.
9. Join the transversal joint gasket and the decorative Alu. extrusion HF40.
10. Insert both elements into the transversal joint, starting with the top façade element.
11. Gradually press both elements into the transversal joint with the bar and a hammer.
12. The steps from 1 onwards are repeated for each new Qbiss One façade element.

[Link to system sealing chapter](#)

! The longitudinal sealing system is executed with integrated gaskets in both longitudinal joints with additional sealing with a sealing compound in the corner rubber linings, while transversal sealing (horizontal joint) is accomplished with a PE-butyl tape applied. If not, adequate sealing and draining of the system can not be guaranteed.

• With brick installation standard centring cross cannot be used. »T« shaped centering tool is used to facilitate element positioning.

# E. INSTALLATION GUIDE

## SYSTEM SEALING

### SEALING DETAILS OVERVIEW

In order to ensure that Qbiss One façade system is air- and watertight, according to the construction and physical requirements of the building, 7 key areas / details must be taken into consideration.

- Sealing between the structure and Qbiss One façade system.
- Longitudinal joint of adjacent Qbiss One façade elements.
- Sealing of transversal and longitudinal joint at the attachment to the drain detail.
- Transversal joint of adjacent Qbiss One façade elements.
- Finishing Qbiss One façade element in the building parapet wall.
- Joints between Qbiss One façade elements and openings (doors, windows and other openings).
- Finishing Qbiss One façade element in the internal corner.

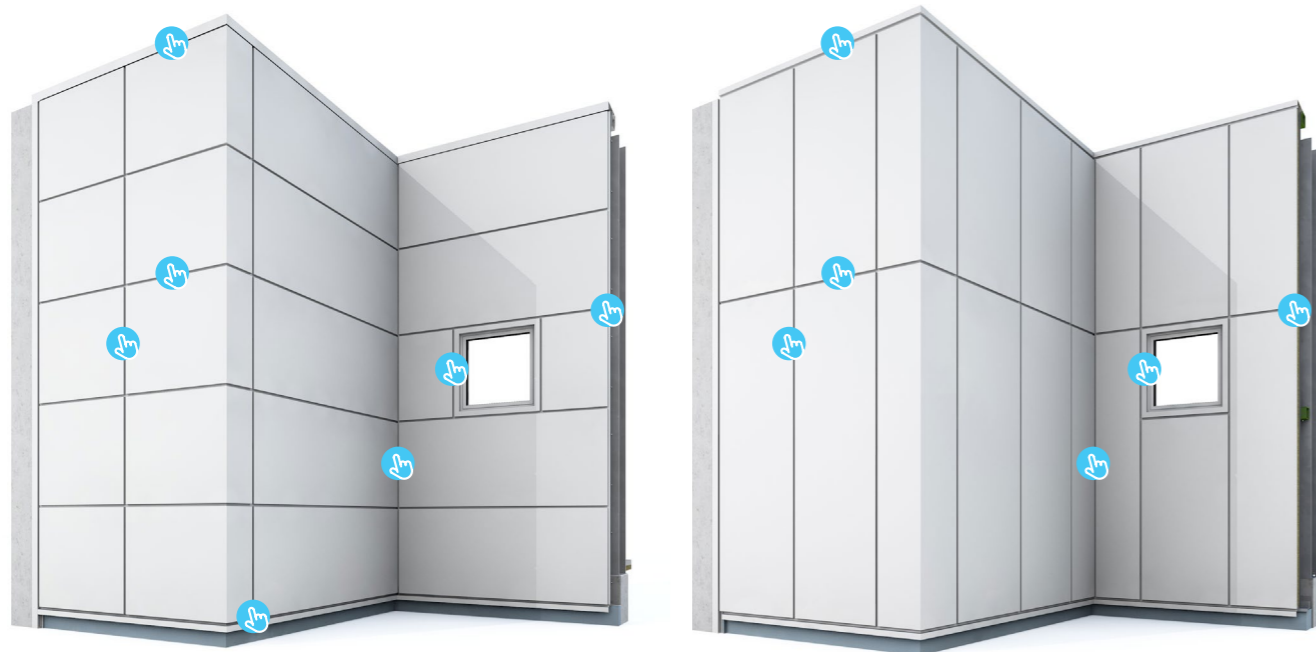

# E. INSTALLATION GUIDE

### SEALING BETWEEN THE STRUCTURE AND QBISS ONE FAÇADE SYSTEM

Sealing tape must be applied to the surface of the structure where Qbiss One façade elements are installed. This assures the correct structural and physical properties of the mantle.



Applied sealing tape on the structure (position: between the structure and the Qbiss One façade elements)

### SEALING THE LONGITUDINAL JOINT OF ADJACENT QBISS ONE ELEMENTS

All Qbiss One façade elements are equipped with gasket profiles in a longitudinal joint groove assuring proper physical construction conditions of the building according to project requirements.

Correct orientation, to enable drainage of water - means the tongue of the longitudinal joint are pointed upwards. The tight contact without air gaps between neighbouring Qbiss One modular façade elements on longitudinal joints must be assured.



Correct sealing in both longitudinal joints

**SEALING OF THE TRANSVERSAL JOINT AT THE ATTACHMENT TO THE DRAIN DETAIL**

An EPDM wet-prevention clamp is inserted into the lower part of the transversal joint, connected to the main beam or above the opening.

The EPDM wet-prevention clamp prevents penetration of rain and enables the evacuation of possible water from transversal joint, thus functioning as a drainage channel.

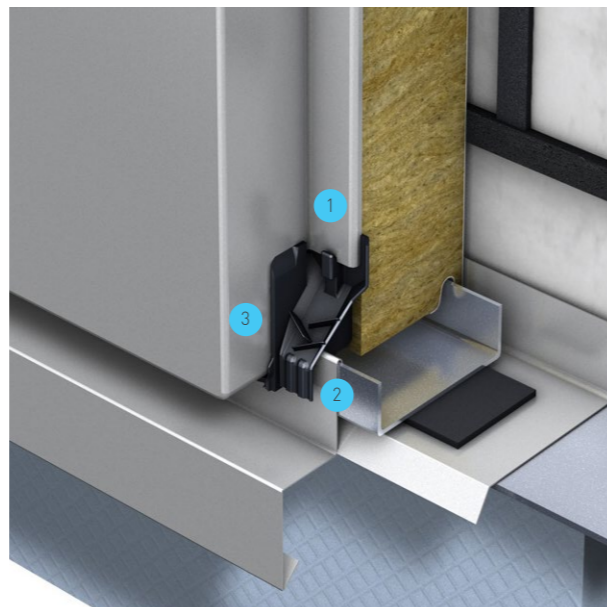

- 1 EPDM transversal gasket
- 2 Attachment to the drain detail
- 3 EPDM wet-prevention clamp

**SEALING OF THE TRANSVERSAL JOINT**

Transversal joints must be sealed to prevent penetration of possible rain or increased air humidity into the joint and interior of the Qbiss One façade elements. Do not leave the façade open and unsealed during heavy rains.

Transversal joint gasket and the decorative Alu. extrusion HF40 must be installed before they are inserted into the transversal joint.

Installation sequence:

- 1 Combine the transversal joint gasket and the decorative extrusion into one before they are inserted into the transversal joint.
- 2 Lubricant must be applied to reduce friction and facilitate the inserting the EPDM gasket together with decorative extrusion HF40 on the transversal joint.
- 3 Insert both elements into the transversal joint, beginning from the top / last Qbiss One façade element.
- 4 Gradually press both elements into the transversal joint by hand (press from the top of the transversal joint gasket to the bottom of the joint).
5. For final position use of additional wood bar with felt and hammer tools.



- 1 EPDM transversal gasket
- 2 Decorative Alu. extrusion HF40
- 3 Fixing screw
- 4 Qbiss One façade element

The same sequence applies to vertical installation (joints are rotated for 90°).

**EXTENDING THE TRANSVERSAL JOINT GASKET**

The extension is performed in case the length of the transversal joint gasket is insufficient, to completely seal the transversal joint.

In this case, extension is performed as follows:

- Cut the top EPDM transversal gasket at an angle of 45°.
- Cut the bottom transversal gasket at an angle of 45°.
- Assemble both EPDM transversal gaskets with a head-to-head joint under a 45° angle. Apply sealing compound onto the joint site.

**EXTENDING THE DECORATIVE ALU. EXTRUSION**

The standard length for decorative Alu. extrusion HF40 is 4 meters. Extension is performed by using a dilatation slot of 10 mm, meaning that the profiles are not in contact in order to prevent internal stress and eventual loss of profiles due to thermal expansion of aluminium.

Profiles are cut to length in manufacturing according to specifics of individual projects and installation details.

**FINISHING THE TRANSVERSAL JOINT GASKET AND THE EXTRUSION ON THE DRAIN DETAIL**

Finishing is performed in the following steps:

- Cutting the EPDM transversal gasket at an angle of 45°.
- Cutting the standing part of the decorative Alu. extrusion HF40 by 40 mm.
- Assembling EPDM transversal gasket and decorative Alu. extrusion HF40.
- Inserting both elements into the transversal joint.

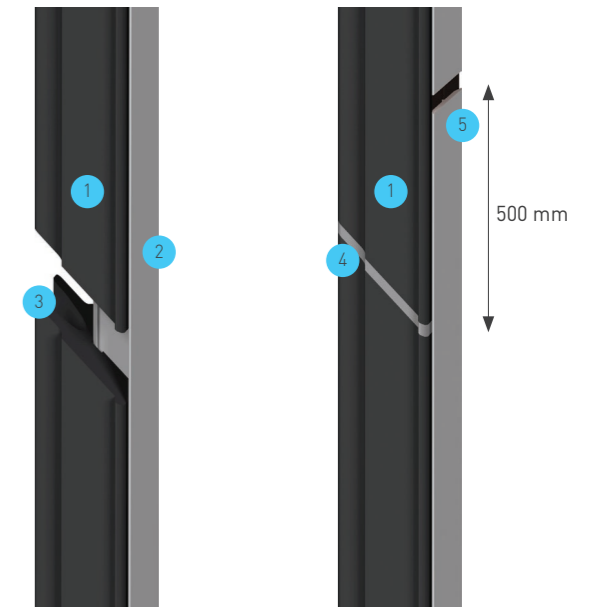

Extending the rubber sealing profile

- 1 EPDM transversal gasket
- 2 Decorative Alu. extrusion HF40
- 3 EPDM transversal gasket cut at an angle of 45°
- 4 Sealing compound
- 5 Dilatation slot of 10 mm

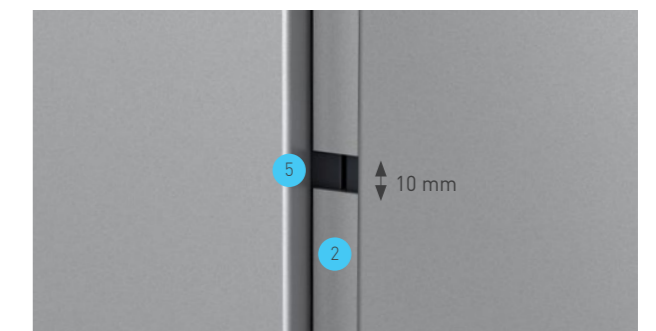

Extending the decorative Alu. extrusion HF40

! Extension of decorative Alu. extrusion HF40 is performed using the dilatation slot of 10 mm.  
 • Minimum distance between extension of the gasket and extension of decorative extrusion HF40 is 500 mm (up or down).

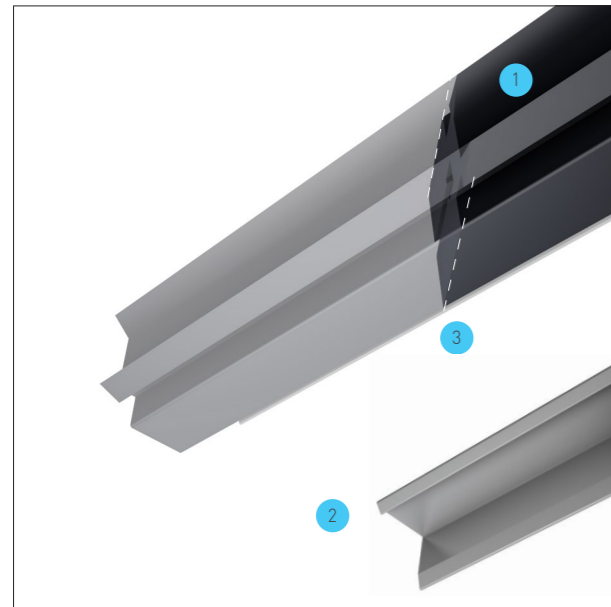

Back view of the transversal joint gasket and the decorative Alu. extrusion HF40 trimming.

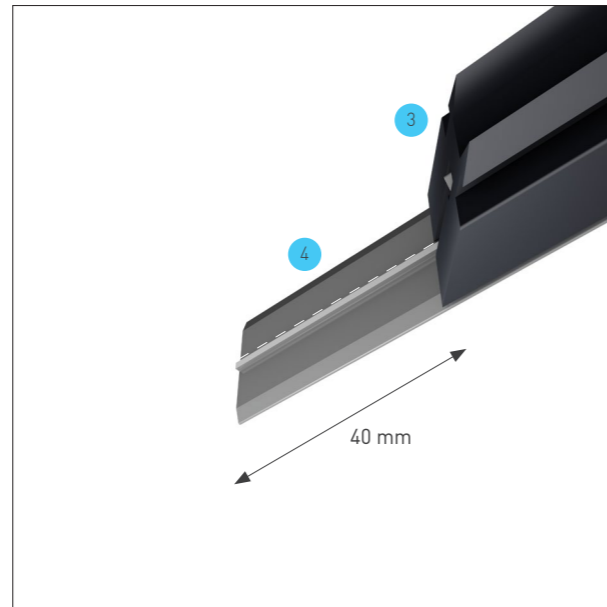

- 1 EPDM transversal gasket
- 2 Decorative Alu. extrusion HF40
- 3 EPDM transversal gasket cut at an angle of 45°
- 4 Cutting off the decorative Alu. extrusion HF40 remainder

### SEALING BETWEEN ELEMENT JOINTS AND OPENINGS

Term openings include windows, doors, infrastructure openings etc.

Joints are usually sealed with window, door and other elements which already have integrated sealing profiles. In some areas, these must be sealed additionally using additional elements or sealing compounds, depending on their purpose.

Sealing of other openings in the area of transversal and longitudinal joint is performed in the same way.



Square gasket for sealing at the location of the transversal joint and the opening.

- 1 Opening
- 2 Square EPDM gasket + sealing compound
- 3 Longitudinal joint

- ! Transversal joint gasket and the decorative Alu. extrusion HF40 must be assembled before they are inserted into the transversal joint.
- All openings / contacts must be sealed using a sealing compound.

### INTERNAL CORNER SEALING

In order to secure additional internal corners, sealing insertion of square gasket is required. This prevents water ingress into Qbiss One façade system. Additional internal corner installation sequences are explained in internal corner detail.

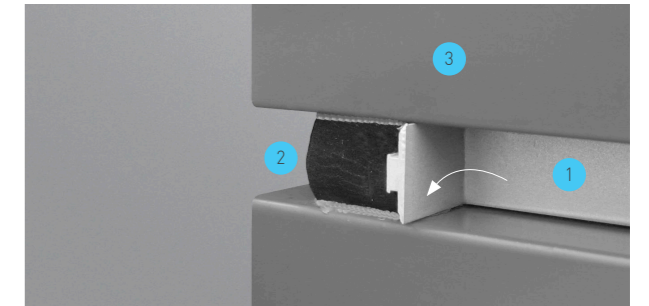

Longitudinal joint sealing.

- 1 Longitudinal joint
- 2 Square EPDM gasket + sealing compound
- 3 Qbiss One façade element

### SEALING OF BUILDING PARAPET WALL

Building parapet wall are sealed by termination of all elements at the transversal or longitudinal joint (depending of the façade element installation direction). Parapet wall cap is attached with a screw to the lining support. 1 screw per meter is added in longitudinal joint to avoid deflection.

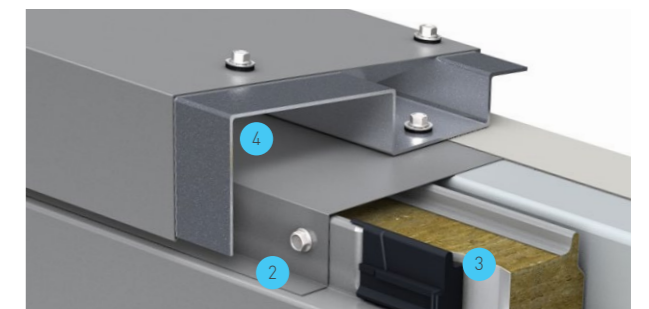

- 1 Transversal joint
- 2 Longitudinal joint
- 3 Junction drip element
- 4 Parapet cap support profile

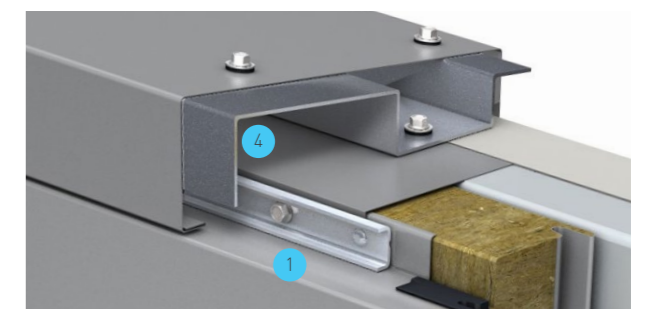

# 🏠 E. INSTALLATION GUIDE

## CHECK-LIST

### STEPS FOR CHECKING THE INSTALLATION

Check the standard steps for evaluating whether the installation is performed according to installation guide and to ensure quality installation.

CHECK-LIST					
STEPS	STEP DESCRIPTION	CORRECT	INCORRECT	CHAPTER	NOTES
1	Substructure meets the tolerance requirements (horizontally, vertically, dimensions, plains).	✓		E 2.5	
2	Façade element supports (vertical and horizontal) installed according to the details, dimensions and plains.			D 1.9	
3	Main structure attachment installed, attached and sealed according to the details.			E 8.3 E 8.7	
4	Sealing tapes installed onto the substructure according to the details.			E 10.0	
5	Protective foil partially removed from the façade elements before the installation and fully after installation.			E 2.3	
6	First row of façade elements installed horizontally with vertical, horizontal joint gaps within tolerances.			E 8.1 E 8.9	
7	Façade elements attached through the internal metal sheet according to the design.			E 8.1 E 8.9	
8	The number of screws used for attachment through the external metal sheet conforms to the design.			E 7.9 E 9.1	
9	Screws for attachment through the external metal sheet tightened accordingly.			D 3.1	
10	Gasket of the transversal joint and the decorative Alu. extrusion HF40 profile inserted into the horizontal, vertical joint with the insertion bar and according to the details for extending and sealing at the beginning and end of gasket.			E 10.2 E 8.1 E 9.3	
11	Corner endings of façades installed, attached and sealed according to the details.			E 10.4	
12	Suitable tools used to cut façade elements.			E 2.1	
13	Window, door and other openings from aluminium profiles installed, attached and sealed according to the details.			E 8.3 E 9.5	
14	Linings installed, attached and sealed according to the details.			E 10.4	



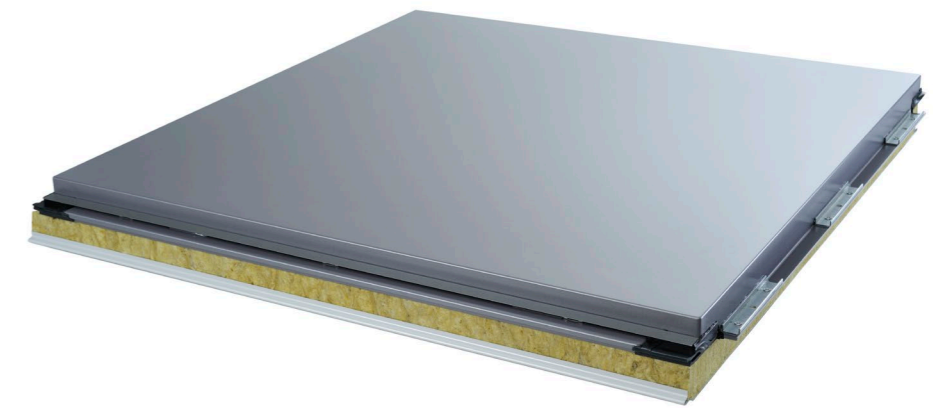

# DESIGN RECOMMENDATIONS

## STRUCTURAL DESIGN RECOMMENDATIONS

### THICKNESS SELECTION

Thickness of the Qbiss One façade element is determined based on project specification.

Thickness of the Qbiss One façade element influences directly on the load-bearing capacity, thermal insulation, fire resistance, and thermal stability of the façade system.

THICKNESSES
80
100
120
133
150
172
200
240
250

### STRUCTURAL DESIGN DATA AND FIXING

Static evidence of Qbiss One façade elements stability and their fixation is required in accordance with applicable legislation (EN 14509) and other national technical regulations, if applicable. Static evidence is a structural analysis of the installation conditions and load for each individual building and façade type.

### DEFINING WIND EFFECTS

Possible wind conditions are a decisive factor for defining allowed installation distances and determining fixing conditions. Wind conditions are defined in accordance with the provisions of EN 1991-1-4:2005 Standard and other national standards, if applicable.

According to the provisions of the European Standard, used in most countries (also applied in similar national standards), a structural analysis of loads for each individual building is required. Performance of such calculations require the following input data:

Building location and data linked to location:

- Location and address,
- Height (above sea level),
- Wind zone or basic wind speed,
- Category of the surrounding location (categories 0, I, II, III, IV),
- Micro-location (building situated at very demanding locations, such as coastlines, hill-tops, ...)

Geometry and type of the building:

- Building shape and dimensions (height, length, width, distribution; Warning: building parapet),
- Type of building (open / partially open / closed building, ceilings, projecting roofs...),
- Size of Qbiss One façade elements,
- Building purpose

Properties of wind conditions cannot be defined without the above data. Use of approximate values based on experience may lead to significant deviations and cause severe difficulties later when determining building façade static stability.

### EDGE ZONES AND THEIR EFFECT ON FAÇADE ELEMENTS AND FIXING CONDITIONS

The effect of winds with regard to the direction of wind can be classified by:

- Effect of wind directed towards the building (+) - wind pressure
- Effect of wind directed away from the building (-) - wind suction

Wind suction, caused by whirling of wind on the edge zones (building edges), is particularly challenging. Suction load in these zones is greater than pressure load; it has a significant effect on façade elements and, therefore, directly determines the fixing conditions. Basic edge zones for simple buildings ( $e < d$ ) are outlined in a diagram on the right.

The table below gives the design coefficients for wind effects.

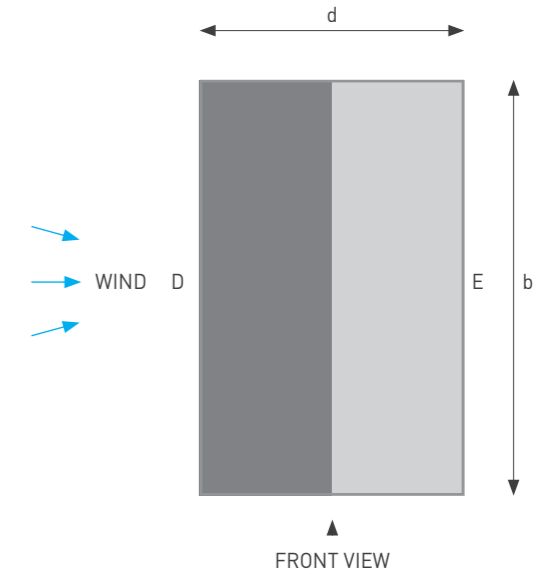

Determining edge zones on a simple rectangular building with proportions  $e < d$ .

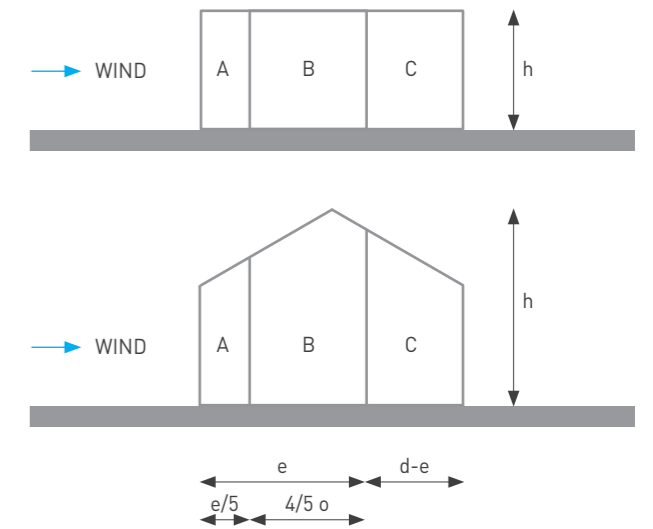

Side-plan for  $e < d$ .

According to EN 1991-1-4 standard.

AREA	A		B		C		D		E	
	C <sub>pe,10</sub>	C <sub>pe,1</sub>	C <sub>pe,10</sub>	C <sub>pe,1</sub>	C <sub>pe,10</sub>	C <sub>pe,1</sub>	C <sub>pe,10</sub>	C <sub>pe,1</sub>	C <sub>pe,10</sub>	C <sub>pe,1</sub>
h/d = 5	- 1.2	- 1.4	- 0.8	- 1.1	- 0.5		+ 0.8	+ 1.0	- 0.7	
h/d = 1	- 1.2	- 1.4	- 0.8	- 1.1	- 0.5		+ 0.8	+ 1.0	- 0.5	
h/d < 0.25	- 1.2	- 1.4	- 0.8	- 1.1	- 0.5		+ 0.7	+ 1.0	- 0.3	

**QBISS ONE SPAN TABLES**

Static evidence of Qbiss One façade elements stability and their fixation is required in accordance with applicable legislation (EN 14509) and other national technical regulations, if applicable). Static evidence is a structural analysis of the installation conditions and load for each individual building and façade type.

**DEFINING FIXING CONDITIONS**

Trimo will prepare structural calculations for your individual case. Please contact technical support. An example of admissible Qbiss One element spans are described below. Fixing of Qbiss One façade elements and admissible spans are defined based on performed fixing tests and the relevant Zulassung Nr. Z-10.49-625 of 24. April 2020 (Power T core) Z-10.49-624 of 15. December 2020 (Power S core) and Zulassung Nr. Z-10.49-550 of 18. June 2018 (Perform C). Fixing of the elements is performed with fixing screw EJOT JT3 - 6 - 5,5 x L (ETA 13/0177 of 23. March 2018) fixed to a 3 mm thick steel substructure of S 235 quality. Before purchase, an official structural calculation, prepared by Trimo, is mandatory.

- Values apply to simple closed buildings - special structural analysis is required in case of parapet wall.
- When determining the allowed distance always consider less favourable value (wind (+), wind (-)), fixing.
- Stated allowed distances apply only to support by width  $b \geq b_{min}$  and number of screws  $n \geq n_{min}$ .
- Stated allowed distances apply only to combination of G/S profiles and sheet metal in thicknesses of 0,7/0,55 mm.
- Deflection of Qbiss One façade elements is limited to L/100 for individual loads.
- Same length and wind effect properties apply for fixing adjacent Qbiss One façade elements.
- Before purchase, an official structural calculation, prepared by Trimo, is mandatory.

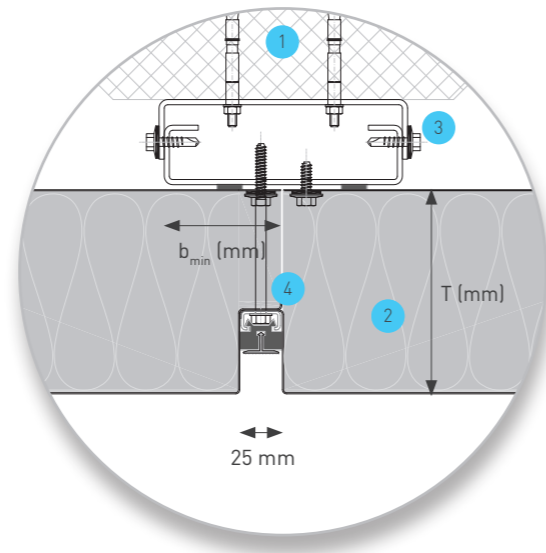

- 1 Concrete column
- 2 Qbiss One façade element
- 3 Fast fixing adjustable levelling substructure
- 4 Fixing screw

**!** A table of allowed distances, possible wind conditions, fixing limitations, necessary minimal support widths, and number of fixing screws, can only be used as a guide for selection and design of the façade system.

Before purchase, an official structural calculation, prepared by Trimo, is mandatory.

**CORE - POWER T**

Table of allowed distances - limitations

Thickness (mm)	max. allowed length of the façade element (m)	WIND PRESSURE [kN/m²]							
		+ 0,25	+ 0,50	+ 0,75	+ 1,00	+ 1,25	+ 1,50	+ 1,75	+ 2,00
80	support width $b_{min}$ (mm)	40	43	52	56	56	56	56	56
	span (m)	6,50	6,09	4,97	3,96	3,17	2,64	2,27	1,98
100	support width $b_{min}$ (mm)	40	50	61	70	70	70	70	70
	span (m)	6,50	6,50	5,78	4,97	3,98	3,31	2,84	2,48
120	support width $b_{min}$ (mm)	40	57	69	80	84	84	84	84
	span (m)	6,50	6,50	6,50	5,69	4,78	3,98	3,41	2,98
133	support width $b_{min}$ (mm)	43	61	75	87	92	92	92	92
	span (m)	6,50	6,50	6,50	6,00	5,09	4,24	3,63	3,18
150	support width $b_{min}$ (mm)	47	67	82	95	102	102	102	102
	span (m)	6,50	6,50	6,50	6,37	5,50	4,58	3,93	3,44
172	support width $b_{min}$ (mm)	52	74	91	105	116	116	116	116
	span (m)	6,50	6,50	6,50	6,50	6,04	5,03	4,31	3,77
200	support width $b_{min}$ (mm)	60	85	104	121	131	131	131	131
	span (m)	6,50	6,50	6,50	6,50	6,38	5,32	4,56	3,99
240	support width $b_{min}$ (mm)	63	89	108	125	140	153	157	157
	span (m)	6,50	6,50	6,50	6,50	6,50	6,25	5,48	4,79
250*	support width $b_{min}$ (mm)	46	66	80	93	104	114	123	131
	span (m)	6,50	6,50	6,50	6,50	6,50	6,50	6,50	6,50

Thickness (mm)	max. allowed length of the façade element (m)	WIND SUCTION [kN/m²]							
		- 0,25	- 0,50	- 0,75	- 1,00	- 1,25	- 1,50	- 1,75	- 2,00
80	span (m)	6,50	5,56	4,54	3,93	3,17	2,64	2,27	1,98
100	span (m)	6,50	6,46	5,28	4,57	3,97	3,31	2,84	2,48
120	span (m)	6,50	6,50	5,99	5,19	4,27	3,56	3,05	2,67
133	span (m)	6,50	6,50	6,31	5,39	4,31	3,59	3,08	2,70
150	span (m)	6,50	6,50	6,50	5,46	4,37	3,64	3,12	2,73
172	span (m)	6,50	6,50	6,50	5,55	4,44	3,70	3,17	2,77
200	span (m)	6,50	6,50	6,50	5,66	4,53	3,78	3,24	2,83
240	span (m)	6,50	6,50	6,50	5,83	4,66	3,88	3,33	2,91
250*	span (m)	6,50	6,50	6,50	5,83	4,66	3,88	3,33	2,91

\* Disclaimer: 250 mm thick Qbiss One façade element is not applicable for German market.  
 Product / Joint / Core / Module: Qbiss One / B-B / Power T / 1000 mm  
 External steel sheet profile / Thickness: G / 0,7 mm  
 Internal steel sheet profile / Thickness: S / 0,55 mm  
 Calculation considers each support fixed with 4, EJOT JT3-6-5,5 x L fixings with Pull out force  $N_{R,d}=3,68$  kN (ETA 13/0177 of 23. March 2018)  
 Valid only for equal panel lengths, L1/L2=1; 3 mm thick substructure



**CORE - POWER S**

Table of allowed distances - limitations

WIND PRESSURE [kN/m <sup>2</sup> ]									
Thickness (mm)	max. allowed length of the façade element (m)	+ 0,25	+ 0,50	+ 0,75	+ 1,00	+ 1,25	+ 1,50	+ 1,75	+ 2,00
80	support width b <sub>min</sub> (mm)	40	40	45	52	55	55	55	55
	span (m)	6,50	6,50	6,37	5,52	4,69	3,91	3,35	2,93
100	support width b <sub>min</sub> (mm)	40	42	51	59	66	69	69	69
	span (m)	6,50	6,50	6,50	6,26	5,60	4,90	4,19	3,67
120	support width b <sub>min</sub> (mm)	40	46	57	66	73	80	83	83
	span (m)	6,50	6,50	6,50	6,50	6,20	5,66	5,04	4,41
133	support width b <sub>min</sub> (mm)	40	49	60	69	77	84	91	91
	span (m)	6,50	6,50	6,50	6,50	6,50	5,94	5,50	4,82
150	support width b <sub>min</sub> (mm)	40	52	63	73	82	89	97	101
	span (m)	6,50	6,50	6,50	6,50	6,50	6,31	5,84	5,36
172	support width b <sub>min</sub> (mm)	40	55	67	78	87	95	103	110
	span (m)	6,50	6,50	6,50	6,50	6,50	6,50	6,22	5,82
200	support width b <sub>min</sub> (mm)	42	59	72	84	93	102	111	118
	span (m)	6,50	6,50	6,50	6,50	6,50	6,50	6,50	6,25
240	support width b <sub>min</sub> (mm)	45	64	79	91	102	111	120	129
	span (m)	6,50	6,50	6,50	6,50	6,50	6,50	6,50	6,50
250*	support width b <sub>min</sub> (mm)	46	66	80	93	104	114	123	131
	span (m)	6,50	6,50	6,50	6,50	6,50	6,50	6,50	6,50

WIND SUCTION [kN/m <sup>2</sup> ]									
Thickness (mm)	max. allowed length of the façade element (m)	- 0,25	- 0,50	- 0,75	- 1,00	- 1,25	- 1,50	- 1,75	- 2,00
80	span (m)	6,50	6,50	5,71	4,94	4,42	3,91	3,35	2,93
100	span (m)	6,50	6,50	6,45	5,59	5,00	4,56	4,20	3,67
120	span (m)	6,50	6,50	6,50	6,20	5,55	5,06	4,69	4,13
133	span (m)	6,50	6,50	6,50	6,50	5,82	5,32	4,78	4,18
150	span (m)	6,50	6,50	6,50	6,50	6,17	5,63	4,87	4,26
172	span (m)	6,50	6,50	6,50	6,50	6,50	5,81	4,98	4,36
200	span (m)	6,50	6,50	6,50	6,50	6,50	5,98	5,13	4,49
240	span (m)	6,50	6,50	6,50	6,50	6,50	6,22	5,34	4,67
250*	span (m)	6,50	6,50	6,50	6,50	6,50	6,22	5,34	4,67

\* Disclaimer: 250 mm thick Qbiss One façade element is not applicable for German market.  
 Product / Joint / Core / Module: Qbiss One / B-B / Power S / 1000 mm  
 External steel sheet profile / Thickness: G / 0,7 mm  
 Internal steel sheet profile / Thickness: S / 0,55 mm  
 Calculation considers each support fixed with 4, EJOT JT3-6-5,5 x L fixings with Pull out force N<sub>R,d</sub>=3,68 kN (ETA 13/0177 of 23. March 2018)  
 Valid only for equal panel lengths, L1/L2=1; 3 mm thick substructure

**CORE - PERFORM C**

Table of allowed distances - limitations

WIND PRESSURE [kN/m <sup>2</sup> ]									
Thickness (mm)	max. allowed length of the façade element (m)	+ 0,25	+ 0,50	+ 0,75	+ 1,00	+ 1,25	+ 1,50	+ 1,75	+ 2,00
80	support width b <sub>min</sub> (mm)	40	40	49	56	61	61	61	61
	span (m)	6,50	5,92	4,83	4,18	3,60	3,00	2,57	2,25
100	support width b <sub>min</sub> (mm)	40	45	55	63	71	76	76	76
	span (m)	6,50	6,50	5,41	4,68	4,19	3,76	3,22	2,82
120	support width b <sub>min</sub> (mm)	40	49	60	69	77	85	91	91
	span (m)	6,50	6,50	5,93	5,13	4,59	4,19	3,86	3,38
133	support width b <sub>min</sub> (mm)	40	51	63	72	81	89	96	98
	span (m)	6,50	6,50	6,19	5,36	4,79	4,38	4,05	3,62
150	support width b <sub>min</sub> (mm)	40	54	66	76	85	93	101	107
	span (m)	6,50	6,50	6,50	5,63	5,04	4,60	4,26	3,95
172	support width b <sub>min</sub> (mm)	40	57	69	80	90	98	106	113
	span (m)	6,50	6,50	6,50	5,94	5,32	4,85	4,49	4,20
200	support width b <sub>min</sub> (mm)	42	60	74	85	95	104	112	120
	span (m)	6,50	6,50	6,50	6,29	5,62	5,14	4,75	4,45
240	support width b <sub>min</sub> (mm)	45	64	78	90	101	111	120	122
	span (m)	6,50	6,50	6,50	6,50	5,99	5,47	5,06	4,52
250*	support width b <sub>min</sub> (mm)	46	65	80	92	103	113	122	127
	span (m)	6,50	6,50	6,50	6,50	6,11	5,58	5,17	4,71

WIND SUCTION [kN/m <sup>2</sup> ]									
Thickness (mm)	max. allowed length of the façade element (m)	- 0,25	- 0,50	- 0,75	- 1,00	- 1,25	- 1,50	- 1,75	- 2,00
80	span (m)	6,50	5,79	4,24	3,18	2,54	2,12	1,82	1,59
100	span (m)	6,50	6,48	4,61	3,46	2,76	2,30	1,97	1,73
120	span (m)	6,50	6,50	4,98	3,73	2,99	2,49	2,13	1,87
133	span (m)	6,50	6,50	5,22	3,91	3,13	2,61	2,24	1,96
150	span (m)	6,50	6,50	5,53	4,15	3,32	2,77	2,37	2,07
172	span (m)	6,50	6,50	5,94	4,45	3,56	2,97	2,54	2,23
200	span (m)	6,50	6,50	6,45	4,84	3,87	3,23	2,77	2,42
240	span (m)	6,50	6,50	6,50	5,39	4,31	3,60	3,08	2,70
250*	span (m)	6,50	6,50	6,50	5,39	4,31	3,60	3,08	2,70

\* Disclaimer: 250 mm thick Qbiss One façade element is not applicable for German market.  
 Product / Joint / Core / Module: Qbiss One / B-B / Perform C / 1000 mm  
 External steel sheet profile / Thickness: G / 0,7 mm  
 Internal steel sheet profile / Thickness: S / 0,55 mm  
 Calculation considers each support fixed with 4, EJOT JT3-6-5,5 x L fixings with Pull out force N<sub>R,d</sub>=3,68 kN (ETA 13/0177 of 23. March 2018)  
 Valid only for equal panel lengths, L1/L2=1; 3 mm thick substructure

**ON-SITE PRODUCTION**

Production of Qbiss One façade elements on the construction site / facility is not possible. In case of additional requirements, elements must be ordered from Trimo and delivered subsequently.

**INCLINED INSTALLATION**

- Allowed façade system inclination inside the building: 10°.
- Allowed external façade inclination: without limitations, if inclination is not limited by structural analysis.
- Allowed inclination of the façade system elements with regards to zero height (floor) 15°.



KJG BUSINESS CENTER  
SLOVAKIA

HORIZONTAL QBISS ONE

2014  
BOUDA A MASÁR, ARCHITEKTONICKÁ KANCELÁRIA S.R.O.



# ADDITIONAL ELEMENTS INSTALLATION

INSTALL IT LIKE A PRO

Additional elements in modern architecture have protective, environmental commercial or aesthetic purpose. They can be installed in forms of blinds, lights, security cameras, signs, advertisements, decorative elements, etc.



**Starting points:**

- It is necessary to ensure the most even distribution of additional equipment weight to the element.
- It is necessary to use min. 2 fasteners/equipment
- Minimum distance of screws/rivets from the edge of the panel and minimum distance between screws/rivets needs to be more than 100 mm.
- The stated starting points apply to static loads, fixing of equipment causing dynamic loads is not allowed.
- **The options below applies to the external sheet thickness  $t = 0.70$  mm.**
- Vertical load needs to be taken into account in the element's design stage.
- Long consoles add additional pull-out forces to screws/rivets. In such case, additional checking of the fastener is required.

**FIXING TO THE EXTERNAL STEEL SHEET**

Weight of additional equipment 0 - 30 kg

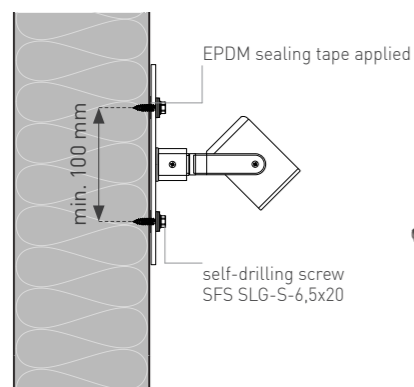

Fixing with self-drilling screws

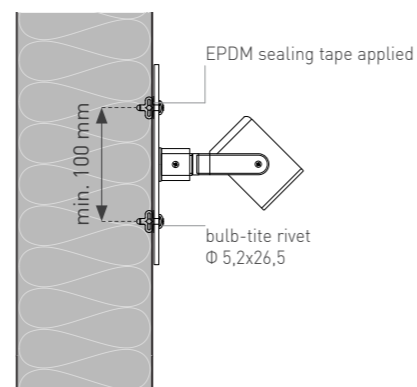

Fixing with rivets



**FIXING THROUGH THE ELEMENT**

Weight of additional equipment 30 - 50 kg

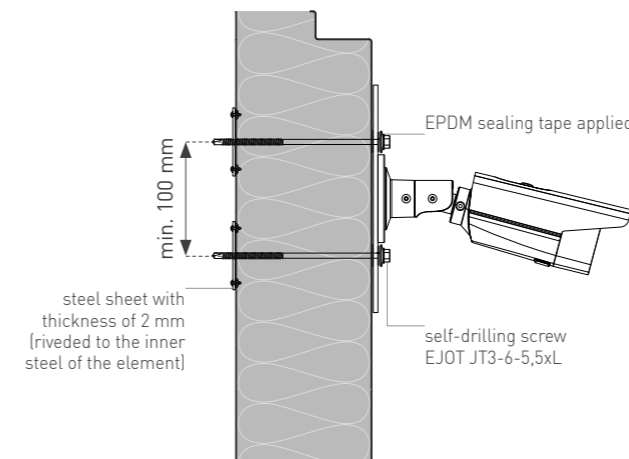

Fixing through the element to a 2 mm steel sheet attached to the internal steel sheet.

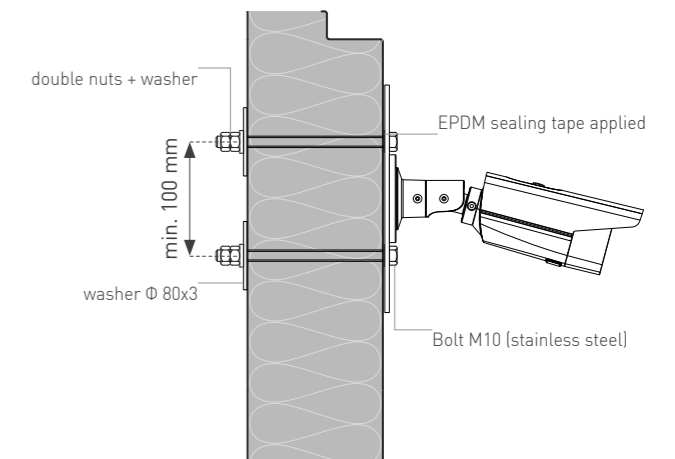

Fixing through the element with M10 bolt (stainless steel), a large washer and double nuts.



! In any case follow the installation instructions of additional element's supplier.  
If Qbiss One is cut or otherwise altered, Trimo can no longer guarantee elements integrity and loadbearing capacity.

### REPLACEMENT OF DAMAGED ELEMENTS

Damage or repair of the Qbiss One wall system, including its range of modular elements, can be performed quickly and efficiently, without any compromise to façade's performance. It can also be appropriately repaired using different approaches depending on the nature of the damage.

#### OPTION 1

A damaged element can be replaced with a new one, simply by tilting upper and lower neighbouring elements outwards, then removing the damaged element to be replaced with a new one.

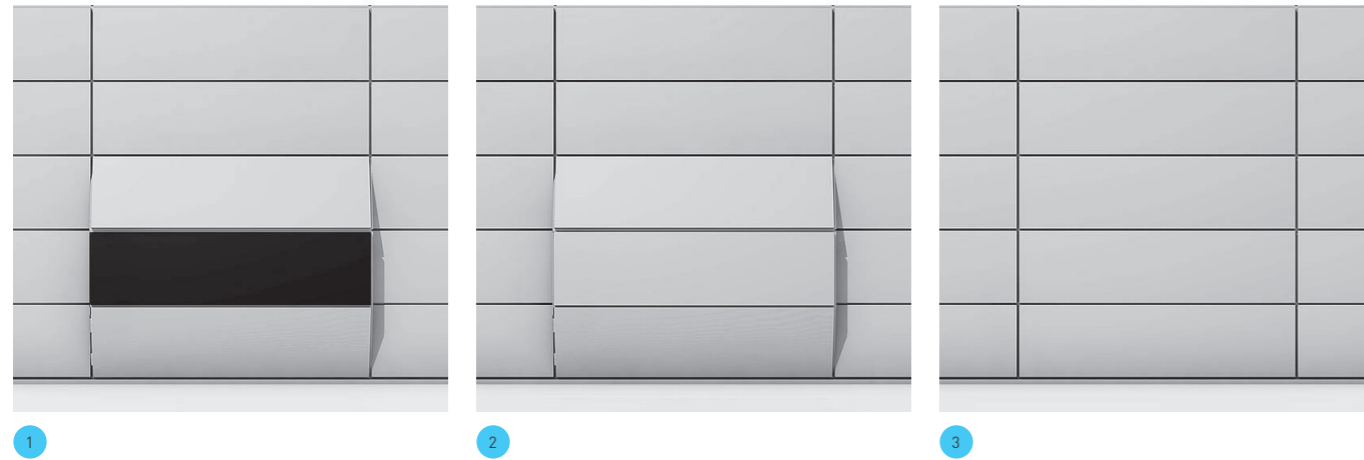

#### OPTION 2

A damaged element can be replaced with a new one, simply by removing all the elements placed above the damaged one, then replacing the damaged element with a new one and the rest of elements placed back.

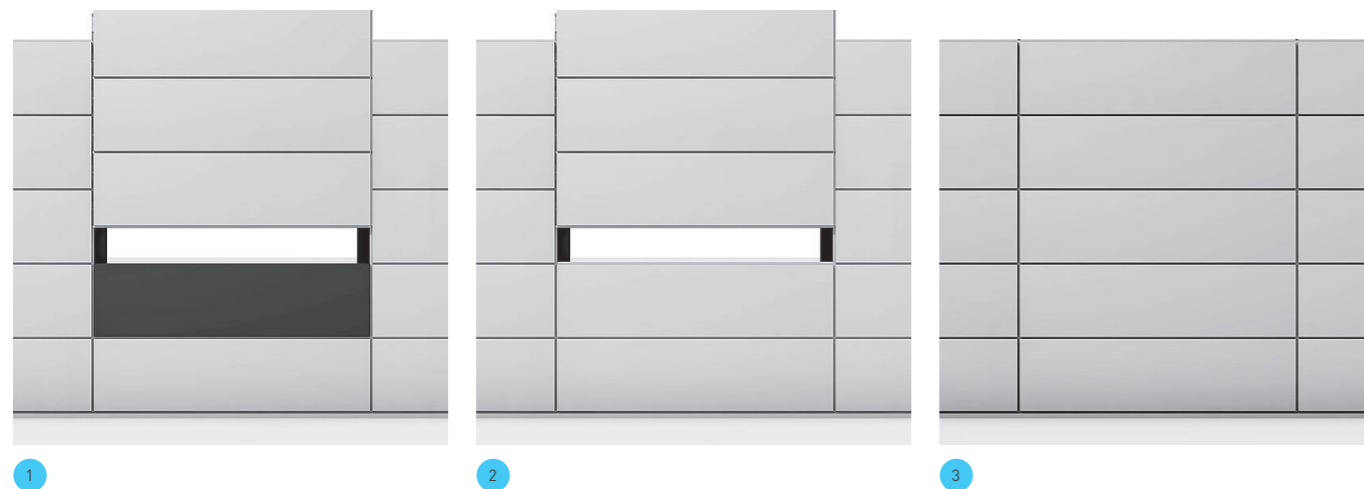

#### OPTION 3

Element can be refurbished simply by repainting.

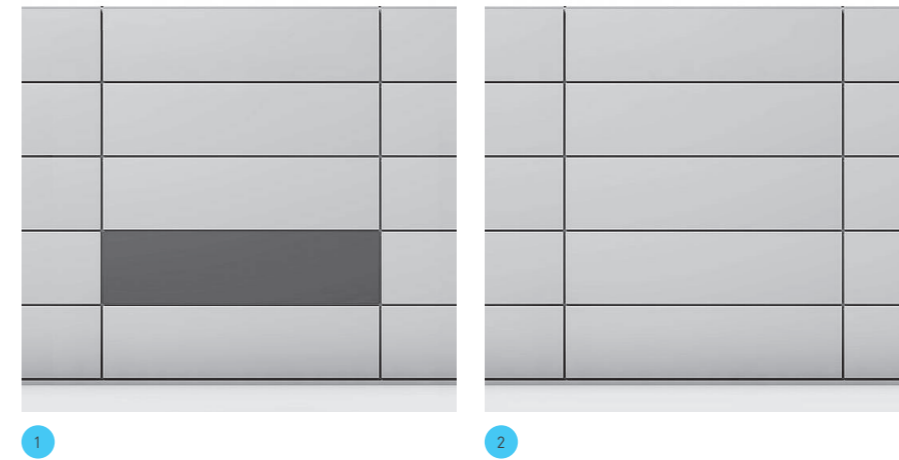

! All façade elements replacement procedures must be consulted and approved by Trimo's technical support team. 🔑

## F. SYSTEM RECOMMENDATIONS

# SPECIFICATION

### SPECIFICATION OF FAÇADE SYSTEM

Qbiss One interactive cutting list is a tool, which helps you order Qbiss One elements. By choosing specific variation of the element, a tool gives you visual feedback so you can easily make your selection. When inserting different dimensions of the elements, a tool warns you in case Qbiss One technical limitations are not met.

#### INTERACTIVE CUTTING LIST REQUIREMENTS

Ordering data, necessary for production:

- Thickness of the façade elements
- Number of pieces
- Type of the façade elements (both-sided, left, right, none)
- Raster length R (distance between screws or, termination at single sided elements, respectively)
- Module - M (module width)
- Number of transversal joints
- Number of EPDM cubic seals for sealing of joints in cut-outs
- Number of drip flashings
- Colour of transversal and longitudinal decorative plates (if different from the colour of the façade element)
- Radius of the façade (in case of segmented installation) measured on external sheet

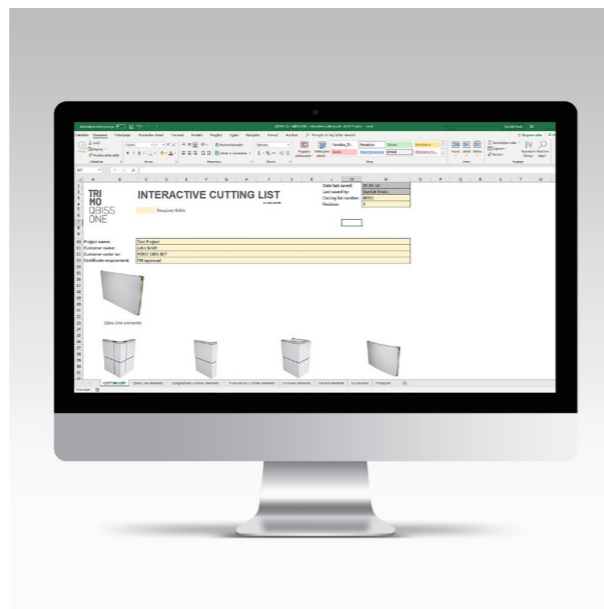

#### INSTALLATION DATA

- Installation direction (left to the right, right to the left)
- Installation type (horizontal, horizontal by shifting, vertical, vertical by shifting)

 [Trimo interactive cutting list](#)

## F. SYSTEM RECOMMENDATIONS

# HANDLING, MAINTENANCE AND WASTE

### PACKING, TRANSPORT AND STORING

This document presents packing, manipulation, transportation and storage of Trimo products. It combines important information for a sales person, a customer, a transport provider and a contractor. Document can be accessed from the linked document below.

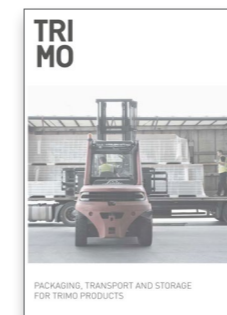

### MAINTENANCE OF BUILDINGS

Instructions are intended for review and maintenance by Trimoterm of Qbiss One elements and flashing elements made of galvanized pre-painted sheet metal, protected with the coil coating organic protective coatings. The instructions can be accessed from the linked document below.



### TREATMENT OF WASTE

The instructions for the treatment of waste of Qbiss One façade elements, insulated with mineral wool and packing materials can be accessed from the linked document below.



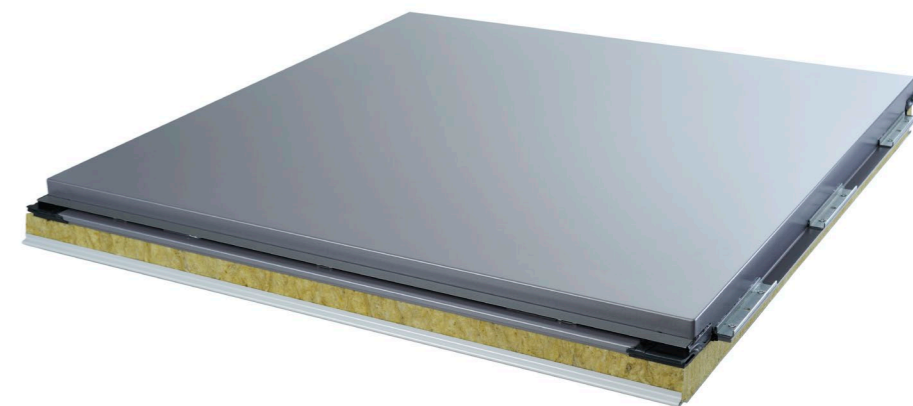

QBISS ONE DESIGN SERVICE

More than 50 years of experience made us experts on the field of design. Based on your input and project requirements we are able to provide a full solution for façade design. Since the world is lately having a tendency to design in 3D environment, based on your wishes we create design shop drawings together with cutting lists in .dwg or .ifc format.

**ENVELOPE DESIGN SERVICES**

Trimo's design team is composed of architects, designers, structural engineers and design and project managers who collectively make design plans and drawings quickly, efficiently, professionally and with an understanding of the customers' needs and expectations.

We monitor the global market by recognising building envelope design in accordance with the prevailing world standards – European EN standards, Russian SNIP, American ASTM, German DIN, etc. We design complete projects or parts of a project according to individual requirements and phases.

Trimo provides a large range of architectural and engineering principle details for sandwich panel façades, walls and roofs. Team of dedicated technical support and product development specialists is known for giving professional advice on bespoke details and individual custom-made solutions.



TECHNICAL SUPPORT SERVICE

From an initial idea to the final implementation: Trimo team provides support at each step of your project, from planning and architectural design to the construction and handover. During the process it is crucial to have a reliable partner.

Technical support includes visualisations, detailing, BIM support, static solutions and managing of changes, information and resources. Our engineers can provide structural calculation for Qbiss One elements, solves non-standard technical details and calculate thermal transmittance of façade – all that precisely and in a blink of an eye.



## 🏠 G. SERVICE & SUPPORT

# ON-SITE SUPPORT

### CLARITY IN OPERATIONS FOR ON-SITE EFFICIENCY

As part of Trimo's commitment to customer service, Trimo can provide a dedicated customer service manager and on-site instructor for specific project to train, monitor and advise on installation.

Trimo's integrated building systems operations and maintenance manual (O&M Manual) form an installation instruction and operator care handbook for Trimo's building systems.

This document may be presented in digital form for ease of access to site operations teams all over the world. The O&M manual is designed to be a user-friendly on-site asset to support clients, operators and users once the Trimo façade systems have been installed.

It should be noted that the manual does not replace Trimo's commitment to after-sales care. Rather, it is a convenient tool that augments our postinstallation support processes.



## 🏠 G. SERVICE & SUPPORT

# PARAMETRIC DESIGN

### PARAMETRIC DESIGN

Architects use various digital tools to help them build models of their designs. However, the majority of these models are built in a way that it makes them difficult to modify interactively. Parametric design addresses this problem by allowing architects to specify relationships among various building elements parameters.

#### **BIM**

Building Information Modelling (BIM) enables quick, precise, and aesthetically perfected production of façade cladding in a 3D virtual environment together with an overview of the parameters, information, and advantages of the chosen system. It also speeds up the communication in the initial design phase.

How does Trimo meet the needs of architects, designers and clients? Trimo BIM software tool ensures the efficient management of information processes throughout the entire lifespan of the building and enables fast and efficient building envelope design.

BIM libraries for all Trimo wall systems are available and suitable for GRAPHISOFT ARCHICAD and Autodesk Revit software.

 [BIM download centre](#)

#### **KEY BIM ADVANTAGES**

Because of their composition, insulated panels conform easily to the BIM format. Libraries provide a wealth of data in terms of thermal and fire performance, durability, coating life expectancy and materials used in manufacturing process.

- Smooth collaboration from the start
- Reduced errors and conflicts
- Higher productivity and safety
- Better cost control and predictability





## 🏠 G. SERVICE & SUPPORT WARRANTY

Qbiss One façade system provides a long lasting aesthetic and functional performance. The use of materials is carefully selected and the latest three layer chrome free coating technology ensures a robust and durable performance together with a high density non-combustible rock wool structural insulation core. With the extensive testing and experiences we have a comfort of our products being utilized for projects with a design life of up to 50 years.

The standard product warranties are 10 years and for paint coatings up to 30 years. This depends on certain terms and conditions, location of the building, colour, and corrosion environment. Such performance makes it ideal choice for public, retail, commercial, office, residential, aviation and other types of superior aesthetic developments that are built to last.



EQUINIX LD6 DATA CENTRE  
UNITED KINGDOM

HORIZONTAL QBISS ONE

2015  
ARUP ASSOCIATES



# PRODUCT MANAGEMENT

## RESEARCH & DEVELOPMENT

Development activities are based on the successful creation of innovative, high-quality products and solutions that meet the needs of all Trimo's clients. The added value of products and solutions is an important factor in the development of Trimo and for its customers. Sustainable development and construction are the guiding principles of Trimo's development strategy for Trimo Group.

The company's latest developments focus on the areas related to reducing energy consumption in buildings and reducing the CO<sub>2</sub> footprint, improving energy balance and making buildings sustainable and more pleasant places to live and work.

R&D always takes into account criteria for calculating the impact of the entire life cycle of the product or solution (LCA - Life Cycle Assessment). In addition to new products, Trimo has successfully developed and accomplished individualised, project-based solutions for its customers.

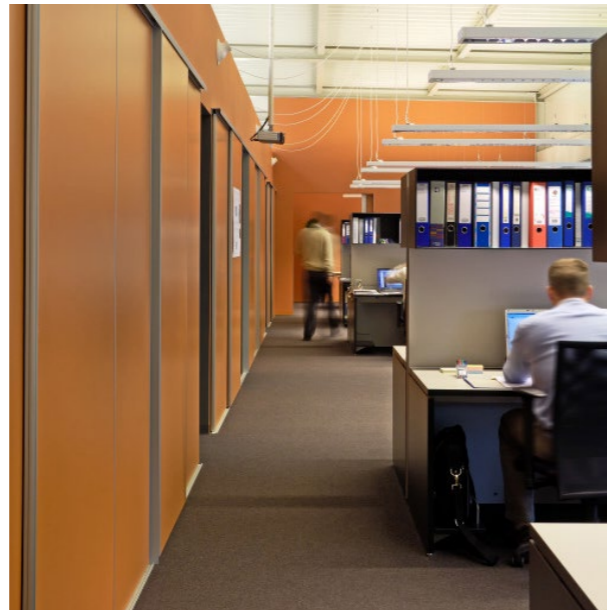

# ASSOCIATED DOCUMENTS

## QBISS ONE DOCUMENTS

Qbiss One book contains all the necessary information about the product. On top of this document, Qbiss One is supported with Qbiss One brochure, Artme technical guide, Product portfolio brochure, Qbiss colour chart leaflet, BIM library instructions, Architectural details and Design details, which can all be attained from below.



! For more detailed information on the technical description material please visit: [www.trimo-group.com](http://www.trimo-group.com).

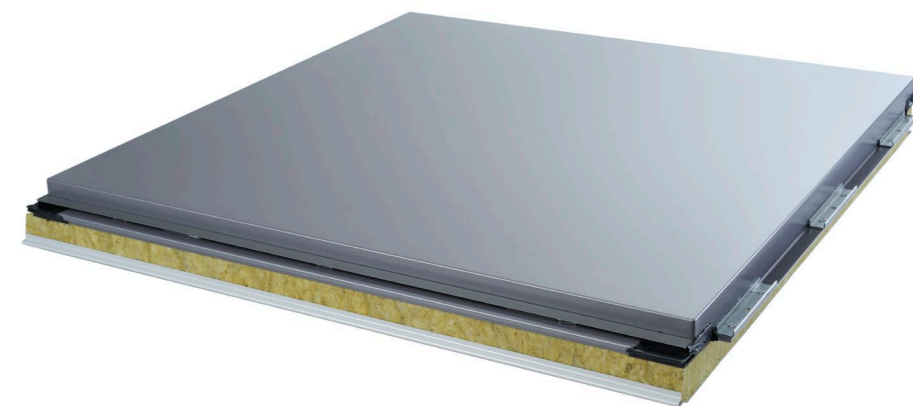



**60+**  
YEARS OF EXPERIENCE

MORE THAN  
**60+ MILLION m<sup>2</sup>**  
OF FAÇADES AND ROOFS PRODUCED

PROJECTS IN MORE THAN  
**120+**  
COUNTRIES WORLDWIDE

MORE THAN  
**25,000+**  
CUSTOMERS & PARTNERS

**CE MARKED & CERTIFIED**



MUNSTERS METAAL HELMOND OFFICE BUILDING  
NETHERLANDS

HORIZONTAL QBISS ONE

2010  
ARCHITECTENBURO JOOSTEN BNA

QBISS ONE BOOK

## H. COMPANY PROFILE COMPANY PRESENTATION



Trimo is a high-quality global supplier of innovative, flexible, functional, energy efficient architectural building envelope solutions. Its customers are at the focus of its operations by understanding their needs and serving them with highest level of service and quality of the products. Trimo's work is underlined with company's core values of partnership, reliability, responsibility, trust, innovation and passion.



Trimo headquarters and production plant in Slovenia.

DEFINING MOMENTS IN THE HISTORY OF THE TRIMO GROUP

Establishment of Trimo

First in the world to produce **Trimoterm** fireproof panels with mineral wool core on continuous line

Production begins in Serbia

Innovative **Qbiss One** façade system introduced to the market

New **corporate identity** for Trimo Group

1961

1974

1987

1989

2007

2008

2009

2010

2016

2019

Production start of thermal-insulated **PU panels**

First modular **space solution unit** produced

Supply of façade panels for construction of the first **CO<sub>2</sub>-neutral building** in the world

**ArtMe** unique façade design receives "red dot" product design award

Global launch of **Qbiss Screen** - innovative metal rainscreen system

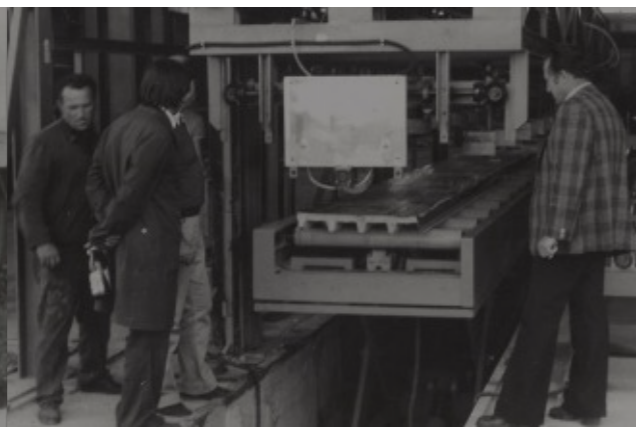

# HEADQUARTERS

## TRIMO D.O.O.

PRIJATELJEVA CESTA 12,

8210 TREBNJE, SLOVENIA

T: +386 (0)7 34 60 200

F: +386 (0)7 34 60 127

TRIMO@TRIMO-GROUP.COM

WWW.TRIMO-GROUP.COM



# GLOBAL PRESENCE

Find your local contact



Trimo Group holds full copyrights on the information and details provided in this document, therefore any unauthorised reproduction and distribution is strictly prohibited. Professional Care has been taken to ensure that the information/details are accurate, correct, complete and not misleading. However, Trimo, including its subsidiaries, does not accept responsibility or liability for errors or information, which is found to be misleading. Information/details in this document are for general purposes only. It is the user's responsibility to check compliance with local laws. Any deviations in details and project solutions are the user's responsibility. Under no circumstances, will we be liable for any loss or damage including without limitation, indirect or consequential loss or damage, or any loss or damage whatsoever arising from lost profits as a result of or in connection with the use of this document. All information issued by Trimo Group is subject to continuous development and information/details contained in this document were current on the date of issue. It is the user's responsibility to obtain the most up-to-date information from Trimo when information/details are used for a project.

The latest version of the document is available at [www.trimo-group.com](http://www.trimo-group.com). The latest version of the published document in English prevails over other translated documents.

For information about the delivery of panels see Trimo's General conditions (<https://trimo-group.com/en/trimo/general-conditions-of-sales>).